

# MODULO

DESIGN EDITION

# MODULO

DESIGN EDITION

# MODULO

## RICERCA, INNOVAZIONE, DESIGN E SOSTENIBILITÀ

Gres, vetro e laminato stratificato applicati ad un telaio di alluminio, sono i componenti protagonisti dell'esclusiva collezione Modulo di Archeda. Una risposta funzionale per l'ambiente bagno che si arricchisce di accessori, complementi e personalizzazioni offrendo la possibilità di scegliere tra un'ampia gamma di materiali sostenibili, a basso impatto ambientale.



### RESEARCH, INNOVATION, DESIGN AND SUSTAINABILITY

Porcelain stoneware, glass and layered laminate applied to an aluminium frame: these are the exclusive protagonists of the Modulo collection by Archeda. These functional ideas for the bathroom are enriched by accessories, occasional furniture and customisations that give you the opportunity to choose from a wide range of sustainable materials with a low environmental impact.

### RECHERCHE, INNOVATION, DESIGN ET DURABILITÉ

Grès, verre et stratifié épais fixés à un cadre en aluminium : tels sont les éléments, au caractère unique, vedettes de la collection Modulo d'Archeda. Une réponse fonctionnelle pour la salle de bains qui s'enrichit d'accessoires, de compléments et de personnalisations, en offrant la possibilité de choisir parmi une vaste gamme de matériaux durables à faible impact sur l'environnement.

### FORSCHUNG, INNOVATION, DESIGN UND NACHHALTIGKEIT

Gres, Glas und Schichtlaminat auf einem Aluminiumrahmen sind die wichtigsten Komponenten der exklusiven Kollektion Modulo von Archeda. Eine funktionelle Antwort für das Badezimmer, die durch Zubehörteile, Zusatzelemente und individuelle Gestaltungsvarianten bereichert wird und die Möglichkeit bietet, aus einem reichhaltigen Angebot von nachhaltigen Materialien mit geringer Umweltbelastung zu wählen.

### INVESTIGACIÓN, INNOVACIÓN, DISEÑO Y SOSTENIBILIDAD

El gres, el vidrio y el laminado estratificado aplicados a un chasis de aluminio son los principales componentes de la exclusiva colección Modulo de Archeda. Una respuesta funcional para el entorno del baño que se enriquece con accesorios, complementos y personalizaciones, ofreciendo la posibilidad de elegir entre una amplia gama de materiales sostenibles de bajo impacto medioambiental.





**MATERIALI**  
 .01 frontali vetro acidato grafite  
 .02 particolari laccati ferro opaco  
 .02 top vetro acidato ferro

**ACCESSORI**  
 lavabo softly nero opaco  
 specchio saturn  
 lampada compasso

# M01

**MATERIALS**  
 .01 front panels acid-etched glass grafite  
 .02 details lacquered matt ferro  
 .02 top acid-etched glass ferro

**ACCESSORIES**  
 washbasin softly matt black  
 mirror saturn  
 lamp compasso

**MATÉRIAUX**  
 .01 façades verre dépoli grafite  
 .02 détails laqués ferro mat  
 .02 P.d.T verre dépoli ferro

**ACCESSOIRES**  
 vasque softly noir mat  
 miroir saturn  
 lampe compasso

**MATERIALIEN**  
 .01 möbelfronten geätzttem glas grafite  
 .02 details lackiert ferro matt  
 .02 waschtischplatte glas geätzt ferro

**ZUBEHÖRE**  
 mattschwarzes waschbecken softly  
 spiegel saturn  
 lampe compasso

**MATERIALES**  
 .01 frentes vidrio grabado al ácido grafite  
 .02 detalles lacados ferro mate  
 .02 encimera vidrio grabado al ácido ferro

**ACCESORIOS**  
 cuba softly negra mate  
 espejo saturn  
 lampara compasso

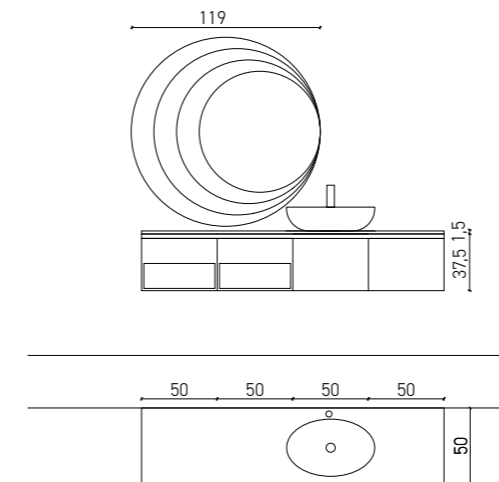

01

02





ARCHEDA MODULO\_8



ARCHEDA MODULO\_9

Valutate il vostro spazio  
ed esaminate le vostre priorità.

Assess your space and take a  
look at your priorities.

Évaluez votre espace et  
examinez vos priorités.

Beurteilen Sie Ihren Raum und  
überprüfen Sie Ihre Prioritäten.

Evalúa tu espacio y examina  
tus prioridades.



ARCHEDA MODULO\_10



ARCHEDA MODULO\_11



**MATERIALI**  
**.01 frontali stratificato grafite venato 6014**  
**.02 particolari laccati ferro opaco**  
**.01 top stratificato grafite venato 6014**

**ACCESSORI**  
 lavabo elite nero opaco  
 specchio filo  
 lampada metro

# M02

**MATERIALS**  
**.01 front panels stratificato grafite venato 6014**  
**.02 details lacquered matt ferro**  
**.01 top stratificato grafite venato 6014**

**ACCESSORIES**  
 washbasin elite matt black  
 mirror filo  
 lamp metro

**MATÉRIAUX**  
**.01 façades stratificato venato grafite 6014**  
**.02 détails laqués ferro mat**  
**.01 P.d.T stratificato venato grafite 6014**

**ACCESSOIRES**  
 vasque elite noir mat  
 miroir filo  
 lampe metro

**MATERIALIEN**  
**.01 möbellfronten stratificato grafite venato 6014**  
**.02 details lackiert ferro matt**  
**.01 waschtischplatte stratificato grafite venato 6014**

**ZUBEHÖRE**  
 mattschwarzes waschbecken elite  
 spiegel filo  
 lampe metro

**MATERIALES**  
**.01 frentes stratificato grafite venato 6014**  
**.02 detalles lacados ferro mate**  
**.01 encimera stratificato grafite venato 6014**

**ACCESORIOS**  
 cuba elite negra mate  
 espejo filo  
 lampara metro

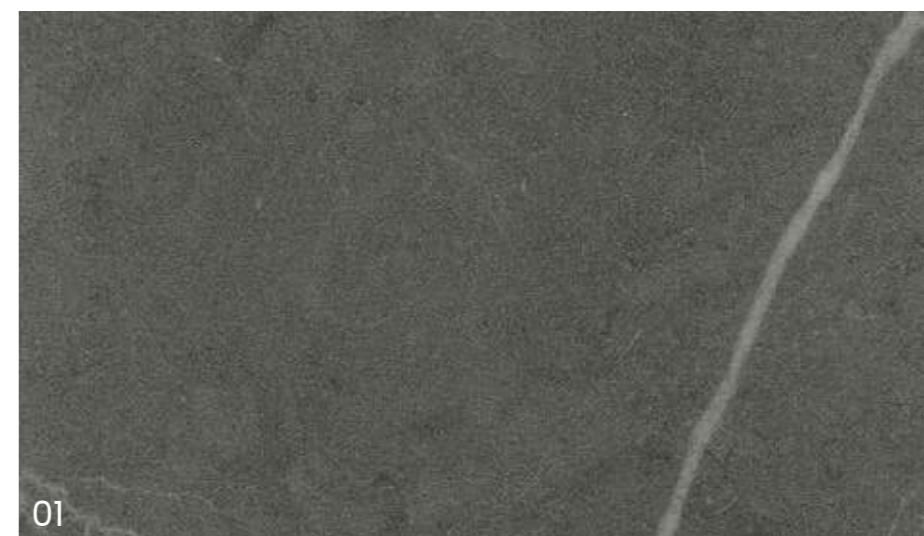
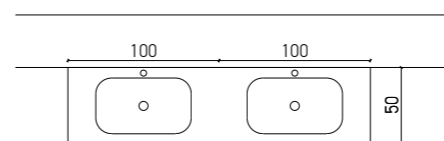
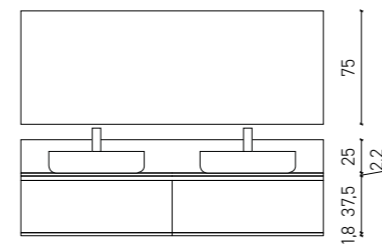

01

02







ARCHEDA MODULO\_16



ARCHEDA MODULO\_17

La sostenibilità deve essere il tuo nuovo paradigma



ARCHEDA MODULO\_18



Sustainability must become your new paradigm

La durabilité doit être votre nouveau paradigme

Nachhaltigkeit sollte zu Ihrem neuen Denkmodell werden

La sostenibilidad debe ser tu nuevo paradigma

ARCHEDA MODULO\_19



**MATERIALI**  
 .01 frontale gres calacatta silk  
 .02 frontale vetro lucido canapa  
 .03 particolari noce canaletto  
 .01 top gres calacatta silk

**ACCESSORI**  
 vasca integrata GZZ5  
 specchio filo  
 lampada compasso

# M03

**MATERIALS**  
 .01 front panel gres calacatta silk  
 .02 front panel glossy glass canapa  
 .03 details noce canaletto  
 .01 top gres calacatta silk

**ACCESSORIES**  
 integrated washbasin GZZ5  
 mirror filo  
 lamp compasso

**MATÉRIAUX**  
 .01 façade gres calacatta silk  
 .02 façade verre poli canapa  
 .03 détails noce canaletto  
 .01 P.d.T gres calacatta silk

**ACCESSOIRES**  
 vasque intégrée GZZ5  
 miroir filo  
 lampe compasso

**MATERIALIEN**  
 .01 möbelfronten gres calacatta silk  
 .02 möbelfronten canapa glänzendem glas  
 .03 details noce canaletto  
 .01 waschtischplatte gres calacatta silk

**ZUBEHÖRE**  
 GZZ5 integriertes Becken  
 spiegel filo  
 lampe compasso

**MATERIALES**  
 .01 frente gres calacatta silk  
 .02 frente vidrio pulido canapa  
 .03 detalles noce canaletto  
 .01 encimera gres calacatta silk

**ACCESORIOS**  
 cuba integrada GZZ5  
 espejo filo  
 lampara compasso

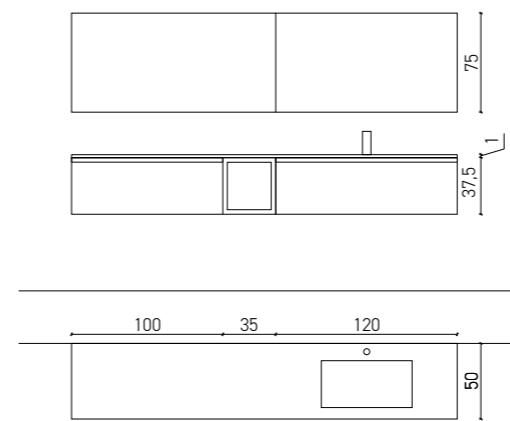

01

02 03





ARCHEDA MODULO\_24



ARCHEDA MODULO\_25

Design minimale significa  
semplificare non banalizzare



A minimalist design  
simplifies without  
undervaluing

Un design  
minimaliste signifie  
simplifier et non pas  
banaliser

Ein minimalistisches  
Design bedeutet  
Vereinfachung, ist  
aber niemals banal

Un diseño  
minimalista significa  
simplificar, no  
trivializar



**MATERIALI**  
.01 frontali specchio fumé 151  
.02 particolari laccati ferro opaco  
.03 top hpl impero 438

**ACCESSORI**  
vasca integrata HJJ5  
specchi jupiter e sputnik  
lampade tube a sospensione

# M04

**MATERIALS**  
.01 front panels fumé mirror 151  
.02 details matt ferro lacquered  
.03 top hpl impero 438

**ACCESSORIES**  
integrated washbasin HJJ5  
mirrors jupiter e sputnik  
lamps tube suspension

**MATÉRIAUX**  
.01 façades miroir fumé 151  
.02 détails laqués ferro mat  
.03 P.d.T hpl impero 438

**ACCESSOIRES**  
vasque intégrée HJJ5  
miroirs jupiter et sputnik  
lampes tube

**MATERIALIEN**  
.01 möbelfronten fumé spiegel 151  
.02 details lackiert ferro matt  
.03 waschtischplatte hpl impero 438

**ZUBEHÖRE**  
HJJ5 integriertes Becken  
spiegel jupiter und sputnik  
lampen tube

**MATERIALES**  
.01 frentes espejo fumé 151  
.02 detalles lacados ferro mate  
.03 encimera hpl impero 438

**ACCESORIOS**  
cuna integrada HJJ5  
espejos jupiter y sputnik  
lamparas tube

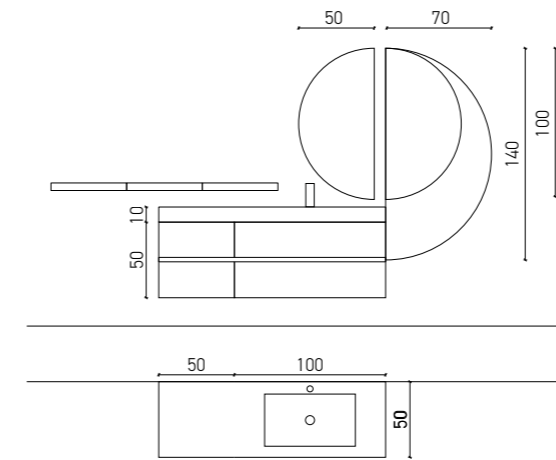

01

02 03





Di cosa senti di avere  
effettivamente bisogno?



What do you feel  
you really need?

Quelles sont les choses dont vous  
pensez avoir effectivement besoin ?

Was brauchen Sie rein  
gefühlsmäßig wirklich?

¿Qué sientes que  
necesitas realmente?





ARCHEDA MODULO\_34



ARCHEDA MODULO\_35

A new take on your home  
with Modulo

Un nouvel air à votre salle de  
bains avec Modulo

Neuer Schwung für Ihren  
Raum mit Modulo

Aires novedosos para tu  
entorno con Modulo



Aria nuova al tuo ambiente  
con Modulo





**MATERIALI**  
**.01 frontali gres zaha stone silk**  
**.02 particolari laccati ferro opaco**  
**.01 top gres zaha stone silk**

**ACCESSORI**  
 vasca integrata GKK5  
 specchio gamma  
 lampade tube a sospensione

# M05

**MATERIALS**  
**01 front panels gres zaha stone silk**  
**02 details matt ferro lacquered**  
**01 top gres zaha stone silk**

**ACCESSORIES**  
 integrated washbasin GKK5  
 mirror gamma  
 lamps tube suspension

**MATÉRIAUX**  
**.01 façades gres zaha stone silk**  
**.02 détails laqués ferro mat**  
**.01 P.d.T gres zaha stone silk**

**ACCESSOIRES**  
 vasque intégrée GKK5  
 miroir gamma  
 lampes tube

**MATERIALIEN**  
**.01 möbelfronten gres zaha stone silk**  
**.02 details lackiert ferro matt**  
**.01 waschtischplatte gres zaha stone silk**

**ZUBEHÖRE**  
 GKK5 integriertes Becken  
 spiegel gamma  
 lampen tube

**MATERIALES**  
**.01 frentes gres zaha stone silk**  
**.02 detalles lacados ferro mate**  
**.01 encimera gres zaha stone silk**

**ACCESORIOS**  
 cuba integrada GKK5  
 espejo gamma  
 lamparas tube

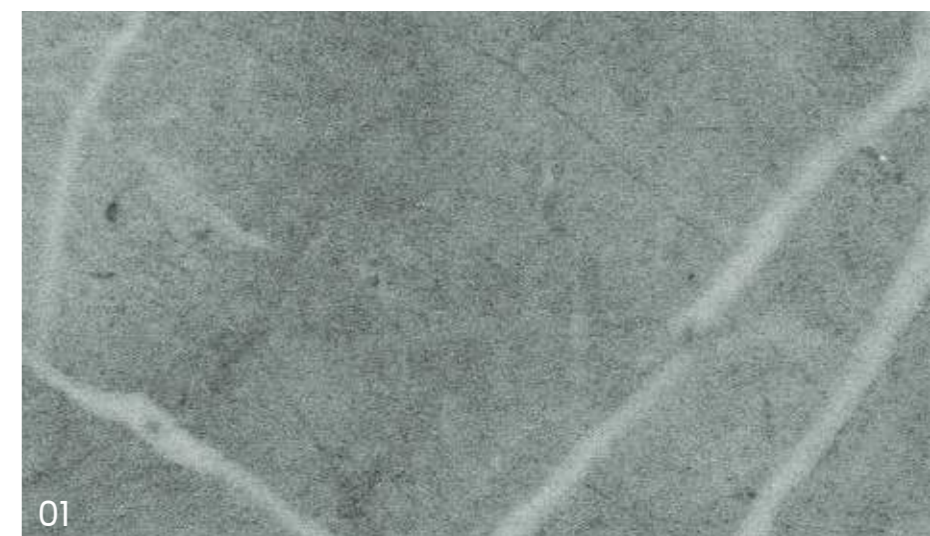
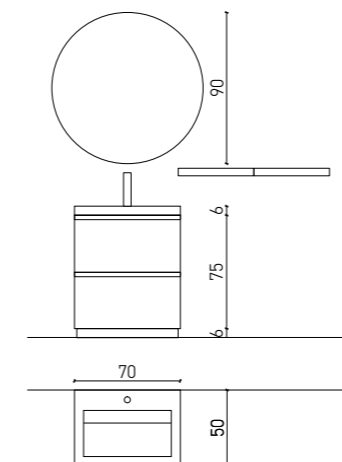

01

02



Fare ordine e tornare ad avere spazio intorno a se



Tidy up to create space all around you

Ranger et avoir de nouveau de la place autour de soi

Aufräumen, um rundherum wieder Platz zu schaffen

Ordenar y volver a tener espacio a tu alrededor







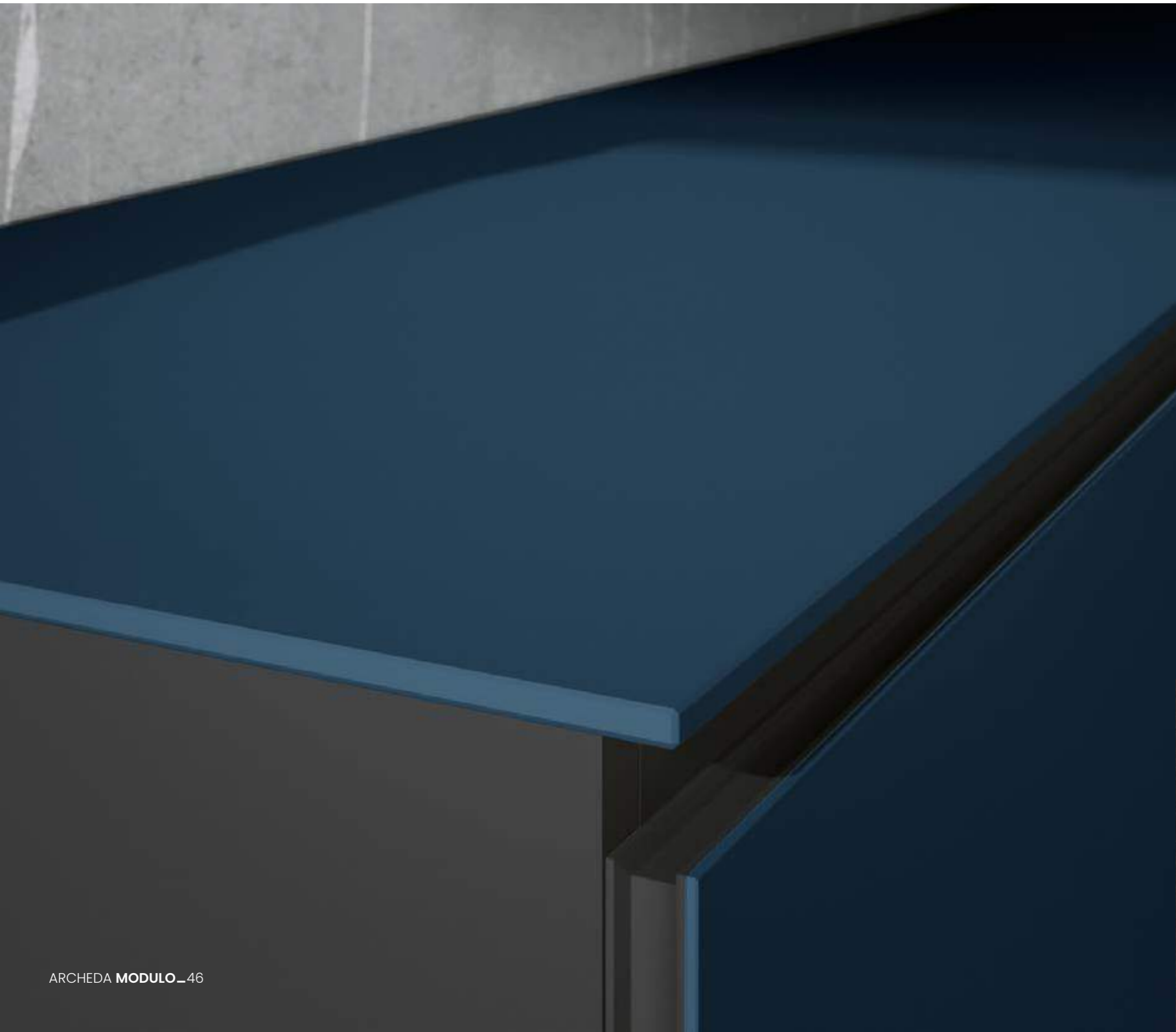

**MATERIALI**  
**.01 frontali vetro acidato oltremare**  
**.02 particolari eucalipto affumicato**  
**.03 top fenix blu fes 754**

**ACCESSORI**  
 vasca integrata HWW5  
 specchio ride  
 lampada pens

# M06

**MATERIALS**  
**.01 front panels acid-etched glass oltremare**  
**.02 details eucalipto affumicato**  
**.03 top fenix blu fes 754**

**ACCESSORIES**  
 integrated washbasin HWW5  
 mirror ride  
 lamp pens

**MATÉRIAUX**  
**.01 façades verre dépoli oltremare**  
**.02 détails eucalipto affumicato**  
**.03 P.d.T fenix blu fes 754**

**ACCESSOIRES**  
 vasque intégrée HWW5  
 miroir ride  
 lampe pens

**MATERIALIEN**  
**.01 möbelfronten geätzttem glas oltremare**  
**.02 details eucalipto affumicato**  
**.03 waschtischplatte fenix blu fes 754**

**ZUBEHÖRE**  
 HWW5 integriertes Becken  
 spiegel ride  
 lampe pens

**MATERIALES**  
**.01 frentes vidrio grabado al ácido oltremare**  
**.02 detalles eucalipto affumicato**  
**.03 encimera fenix blu fes 754**

**ACCESORIOS**  
 cuba integrada HWW5  
 espejo ride  
 lampara pens

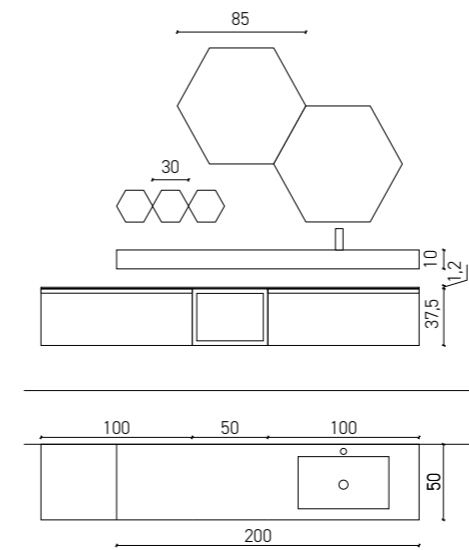

01

02 03



Eco design, il nuovo  
denominatore comune

Eco design, the new  
common denominator

Eco design, le nouveau  
dénominateur commun

Ökodesign, der neue  
gemeinsame Nenner

Diseño ecológico, el nuevo  
denominador común

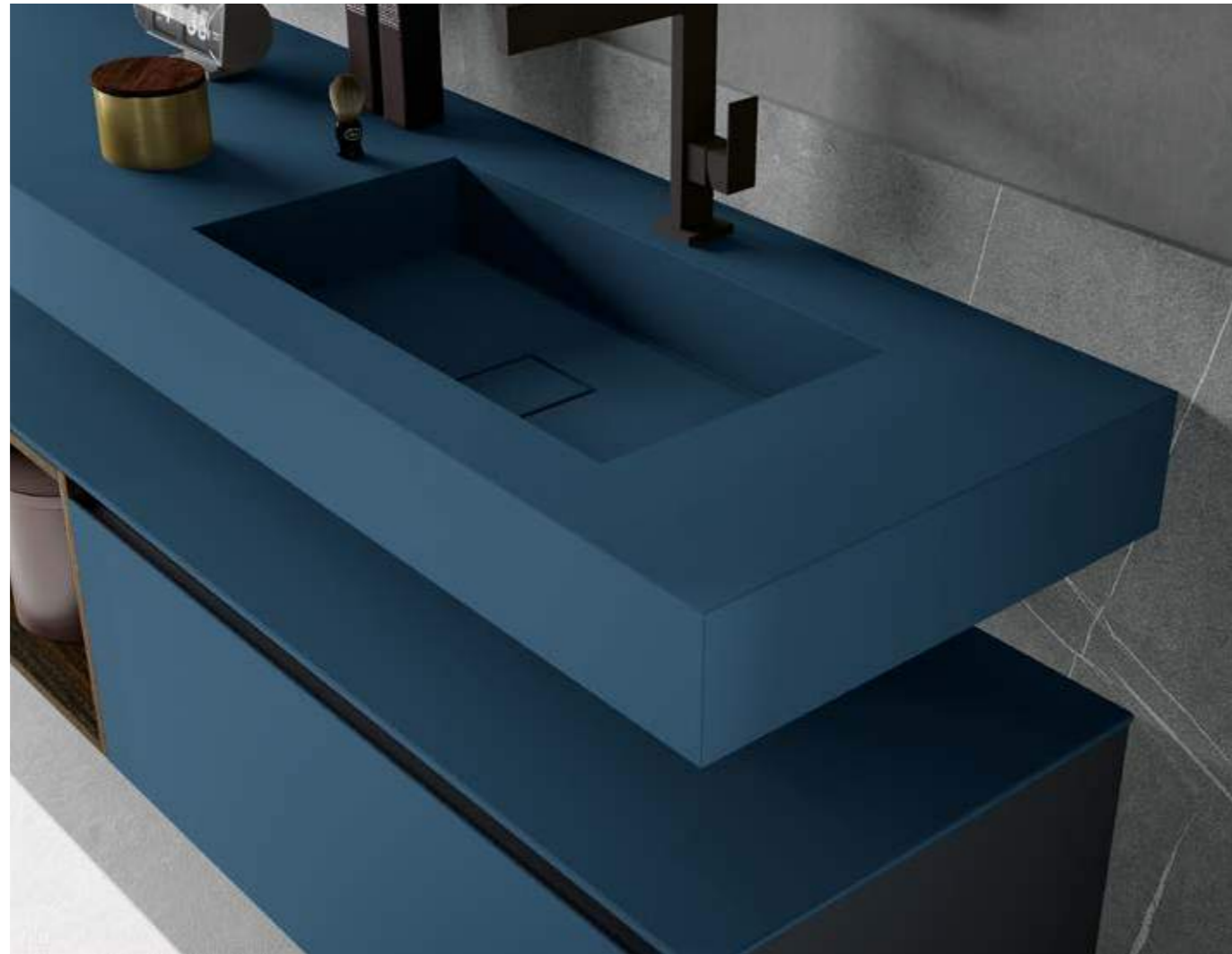



ARCHEDA MODULO\_52

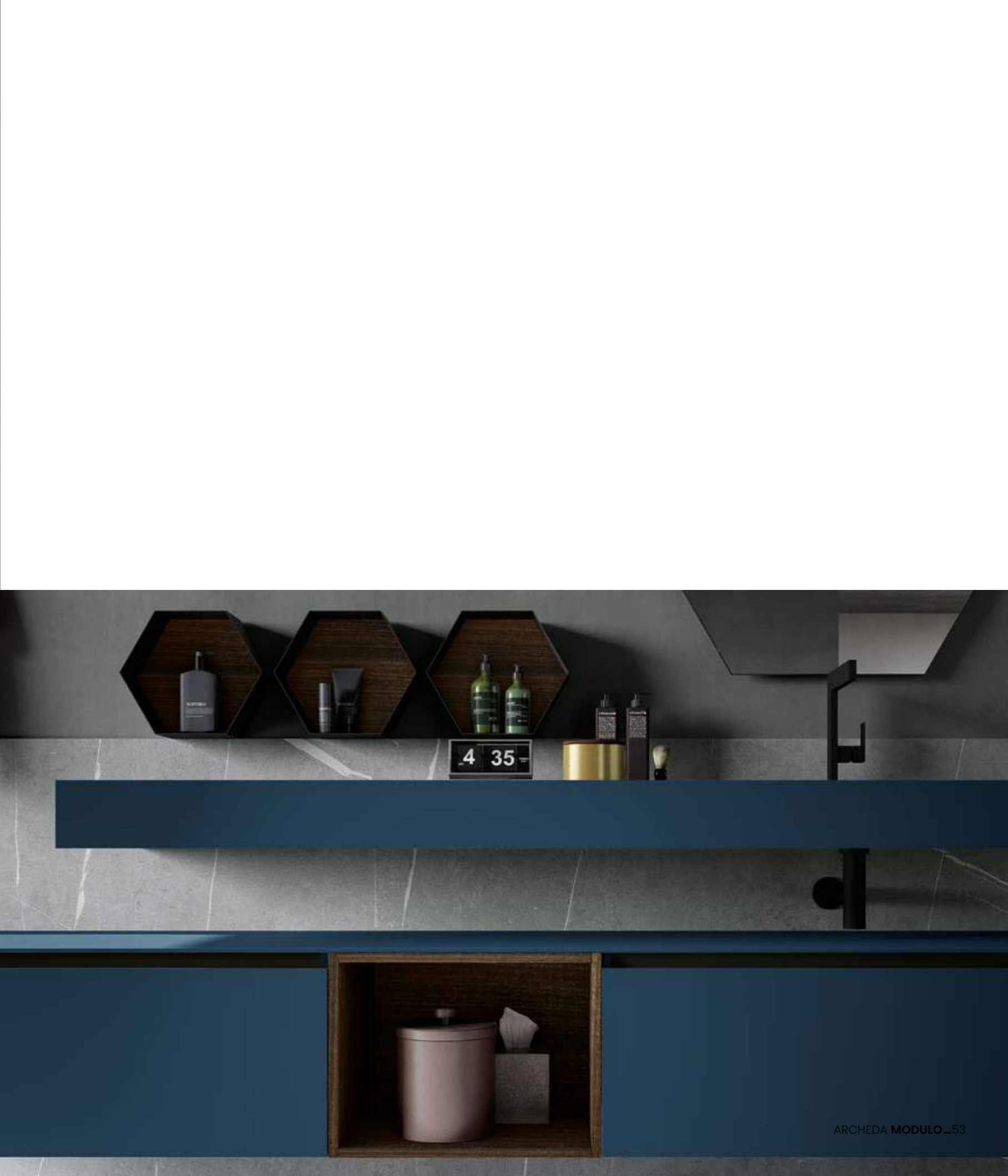

ARCHEDA MODULO\_53



**MATERIALI**  
 .01 frontali gres calatorao silk  
 .02 particolari laccati ferro opaco  
 .01 top gres calatorao silk

**ACCESSORI**  
 vasca integrata GJJ5  
 specchi sky e line retro-illuminati

# M07

**MATERIALS**  
 .01 front panels gres calatorao silk  
 .02 details lacquered ferro matt  
 .01 top gres calatorao silk

**ACCESSORIES**  
 integrated washbasin GJJ5  
 mirrors sky e line backlit

**MATÉRIAUX**  
 .01 façade gres calatorao silk  
 .02 détails laqués ferro mat  
 .01 P.d.T gres calatorao silk

**ACCESSOIRES**  
 vasque intégrée GJJ5  
 miroirs sky et line avec éclairage périmétral

**MATERIALIEN**  
 .01 möbelfronten gres calatorao silk  
 .02 details lackiert ferro matt  
 .01 waschtischplatte gres calatorao silk

**ZUBEHÖRE**  
 GJJ5 integriertes Becken  
 hinterleuchtete spiegel sky und line

**MATERIALES**  
 .01 frentes gres calatorao silk  
 .02 detalles lacados ferro mate  
 .01 encimera gres calatorao silk

**ACCESORIOS**  
 cuba integrada GJJ5  
 espejos retroiluminados sky y line

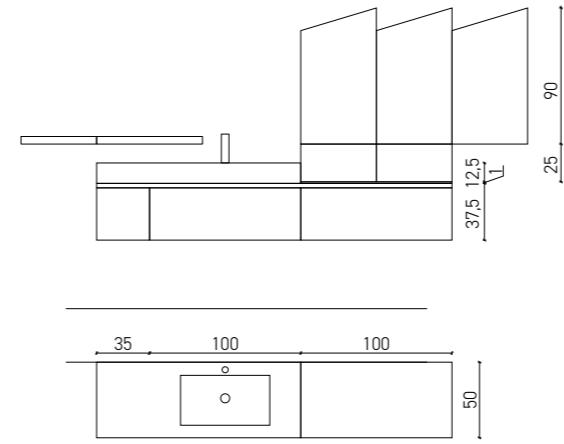

02





“Less is more”, l'essenziale di cui non puoi fare a meno

Less is more: the essentials you just can't do without

« Less is more », l'essentiel auquel vous ne pouvez pas renoncer

„Less is more“, die grundsätzlichen Dinge, auf die Sie nicht verzichten können

«Menos es más», lo esencial de lo que no puedes prescindir





Un pizzico di vanità con  
uno specchio di design!

A touch of vanity with a  
designer mirror!

Un brin de vanité avec un  
miroir design !

Ein wenig Eitelkeit mit  
einem Designerspiegel!

¡Un toque de vanidad con  
un espejo de diseño!





**MATERIALI**  
**.01 frontale vetro acidato bianco**  
**.02 particolari rovere nordico naturale**  
**.03 top tecnoril**

**ACCESSORI**  
lavabo inca tecnoril  
specchio ride  
lampada pens

# M08

**MATERIALS**  
**.01 front panel acid-etched glass bianco**  
**.02 details rovere nordico naturale**  
**.03 top tecnoril**

**ACCESSORIES**  
washbasin inca tecnoril  
mirror ride  
lamp pens

**MATÉRIAUX**  
**.01 façades verre dépoli bianco**  
**.02 détails rovere nordico naturale**  
**.03 P.d.T tecnoril**

**ACCESSOIRES**  
vasque inca tecnoril  
miroir ride  
lampe pens

**MATERIALIEN**  
**.01 möbelfronten bianco geätzttem glas**  
**.02 details rovere nordico naturale**  
**.03 waschtischplatte tecnoril**

**ZUBEHÖRE**  
tecnoril waschbecken inca  
spiegel ride  
lampe pens

**MATERIALES**  
**.01 frentes vidrio grabado al ácido bianco**  
**.02 detalles rovere nordico naturale**  
**.03 encimera tecnoril**

**ACCESORIOS**  
cuba inca tecnoril  
espejo ride  
lampara pens

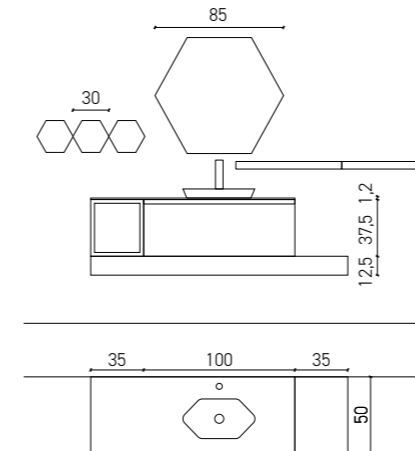

01

02 03



Sostenibilità, impiego di materiali riciclabili a basso impatto ambientale.

Sustainability means using recyclable materials with a low environmental impact

Durabilité, utilisation de matériaux recyclables à faible impact sur l'environnement

Nachhaltigkeit, Verwendung von recycelbaren Materialien mit geringer Umweltbelastung

Sostenibilidad, uso de materiales reciclables con un bajo impacto medioambiental





ARCHEDA MODULO\_68



ARCHEDA MODULO\_69



# SPECCHI

MIRRORS - MIROIRS  
SPIEGELN - ESPEJOS



GOCCIA

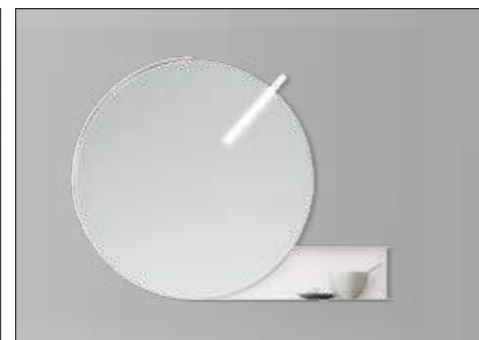

VIRGOLA



SKY + LINE

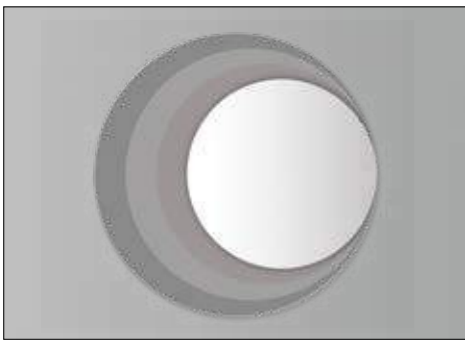

SATURN

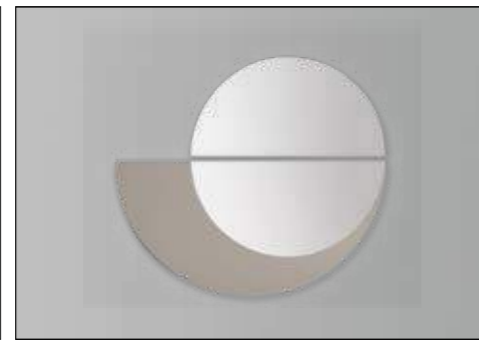

JUPITER + SPUTNIK

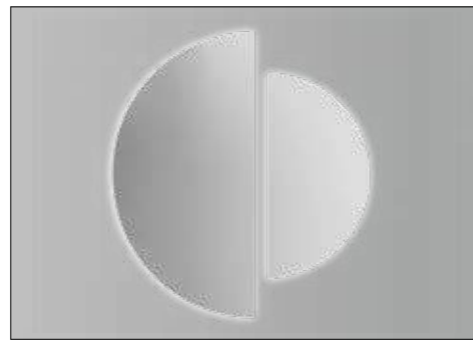

SPUTNIK



RIDE



BEE



# INSIDE: ACCESSORI PER CASSETTI

INSIDE: ACCESSORIES FOR DRAWERS  
INSIDE: ACCESSOIRES POUR TIROIRS  
INSIDE: ZUBEHÖR FÜR SCHUBLADEN  
INSIDE: ACCESORIOS PARA CAJONES



L. 50 P. 50



L. 60 P. 50



L. 70 P. 50



L. 85 P. 50



L. 100 P. 50



L. 105 P. 50



L. 120 P. 50

# ANTA MODULO

MODULO FRONT - FAÇADE MODULO  
MÖBELFRONT MODULO - FRENTE MODULO

## Riciclabile e resistente all'acqua

Recyclable and water resistant

Recyclable et résistant à l'eau

Recyclbar und wasserabweisend

Reciclable y resistente al agua



### Dettaglio telaio alluminio smontato

Detail of the disassembled aluminum frame

Détail du cadre en aluminium démonté

Detail des zerlegten Aluminiumrahmen

Detalle del marco de aluminio desmontado

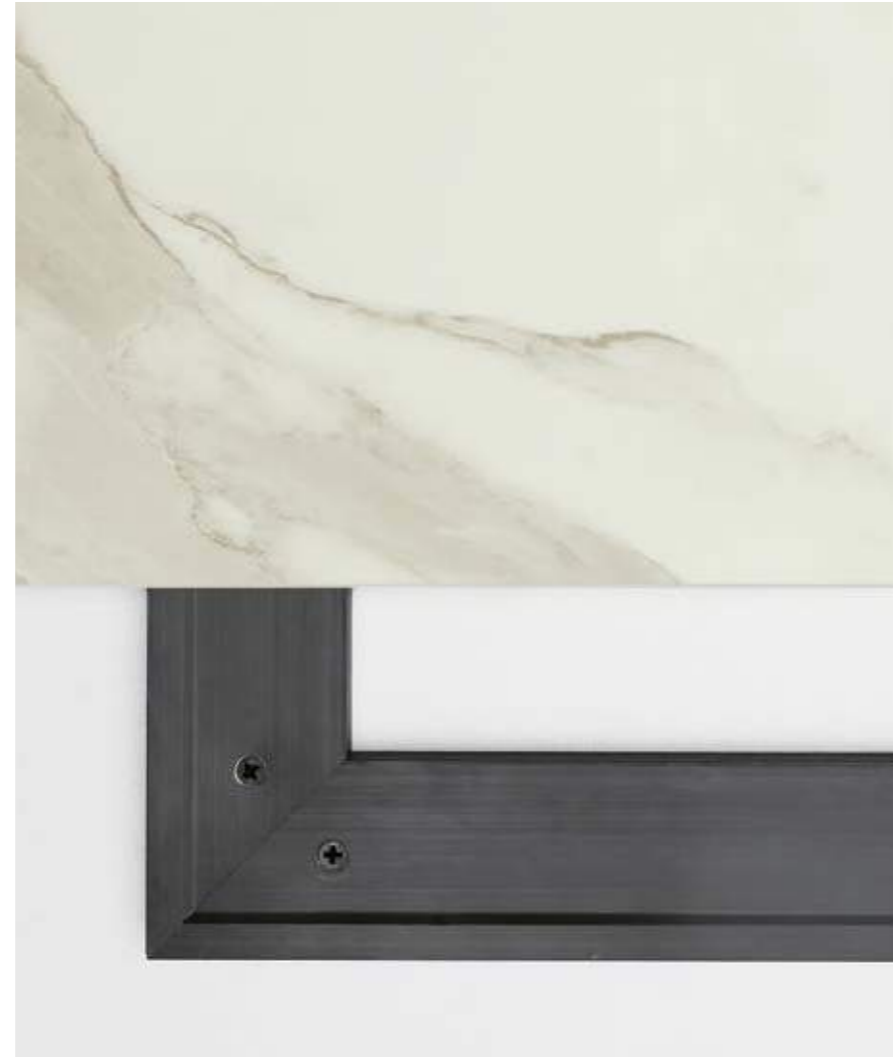

### Pannello incollato su telaio

Panel glued to the frame

Panneau collé au cadre

Platte auf den Rahmen geklebt

Panel pegado el marco

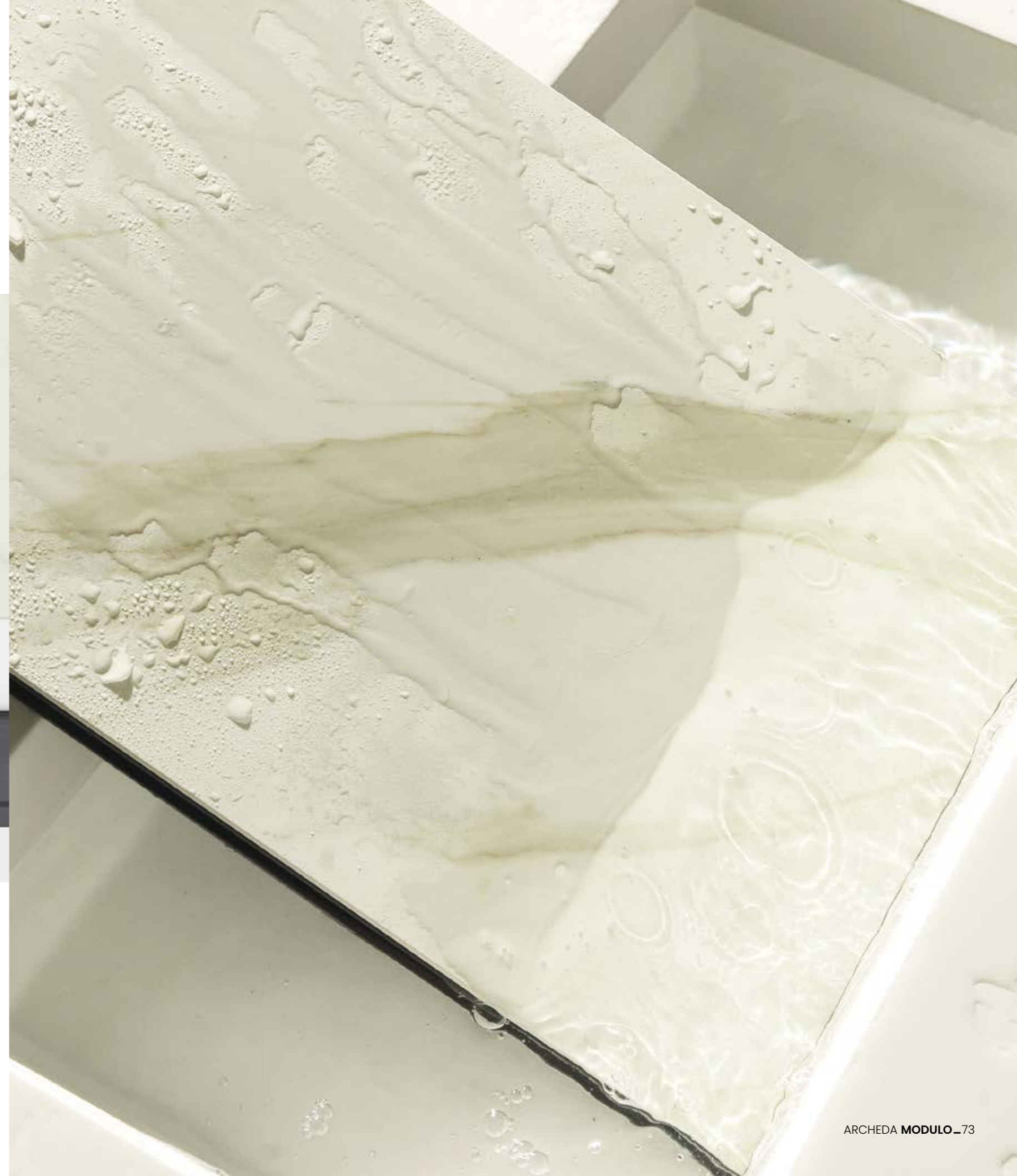

# MATERIALI

MATERIALS - MATÉRIAUX  
MATERIALIEN - MATERIALES

## Telaio alluminio color ferro

Aluminium frame colored Ferro  
Cadre en aluminium couleur ferro  
Ferrofarbener Aluminiumrahmen  
Marco de aluminio color ferro



## Vetro acidato / lucido

Acid-etched/glossy glass  
Verre dépoli / poli  
Geätzttem/glänzendem glas  
Vidrio grabado al ácido/pulido

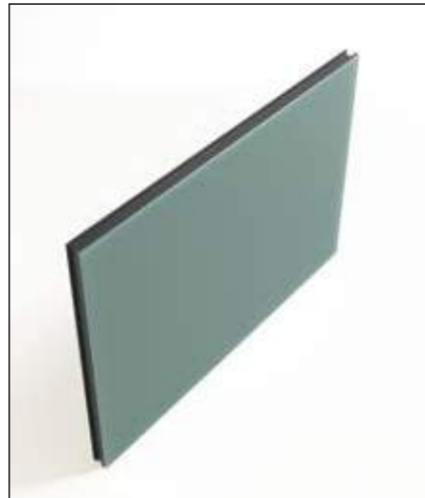

## Gres

Gres  
Gres  
Gres  
Gres



## Specchio fumè grigio

smoked gray mirror  
Miroir fumé gris  
Grau Geräuchertem spiegel  
Espejo ahumado gris

## Laminato stratificato

Stratificato - layered laminate  
Stratificato - stratifié en couches  
Stratificato - geschichtetes Laminat  
Stratificato - laminado en capas

# APPLICAZIONI

APPLICATIONS - APPLICATIONS  
ANWENDUNGEN - APLICACIONES



Top  
Top  
Plan de toilette  
Waschtischplatte  
Encimera

Anta  
Door  
Porte  
Tür  
Puerta

Cornice  
Frame  
Cadre  
Rahmen  
Marco

La scelta dei materiali non è stata casuale, i pannelli utilizzati sono totalmente resistenti all'umidità. ARCHEDA dopo aver eseguito specifici test di laboratorio ha deciso di adottare per le ante MODULO l'alluminio, il vetro, il gres e il laminato stratificato. Questo è il motivo per cui abbiamo escluso tutti i componenti non impermeabili. Pensato per essere funzionale, facile da pulire e durare nel tempo.

We didn't choose our materials by chance; the panels used are completely moisture-resistant. After having performed specific lab tests we at ARCHEDA decided to use aluminium, glass, porcelain stoneware and layered laminate for our MODULO doors. That's why we resolved to exclude any non-waterproof parts. Designed to be functional, easy to clean and durable.



Alzata  
Upstand  
Dossieret  
Aufsatz  
Copete

Le choix des matériaux n'a pas été fait au hasard : les panneaux utilisés sont totalement résistants à l'humidité. Après avoir effectué des essais de laboratoire spécifiques, ARCHEDA a décidé d'adopter, pour le revêtement des portes MODULO, l'aluminium, le verre, le grès et le stratifié épais. Elle a donc exclu tous les matériaux non imperméables afin que ce modèle soit fonctionnel, facile à nettoyer et avec un long cycle de vie.

Bei der Wahl der Materialien wurde nichts dem Zufall überlassen, die verwendeten Platten sind absolut feuchtigkeitsbeständig. Nach der Durchführung spezifischer Labortests hat sich ARCHEDA für Aluminium, Glas, Gres und Schichtlaminat zur Herstellung der Türen MODULO entschieden. Auf diese Weise haben wir alle nicht wasserundurchlässigen Bauteile ausgeschlossen. Die Materialien sind funktionell, einfach zu reinigen und langlebig.

La elección de los materiales no ha sido al azar, los paneles utilizados son totalmente resistentes a la humedad. Tras realizar pruebas de laboratorio específicas, ARCHEDA ha decidido utilizar aluminio, vidrio, gres y laminado estratificado para las puertas MODULO. Por eso hemos excluido todos los componentes no impermeables. Diseñado para ser funcional, fácil de limpiar y duradero.

# FRONTALI

telaio alluminio color ferro con  
pannello sp. 4 mm

FRONT PANELS

Aluminum frame colored ferro  
with panel th. 4 mm

FAÇADES

Cadre en aluminium couleur ferro  
avec panneau ep. 4 mm

FRONTEN

Ferrofarbener Aluminiumrahmen  
mit Platte st.4 mm

FRENTES

Marco de aluminio color ferro  
y panel esp. 4 mm



vetro  
acidato /  
lucido

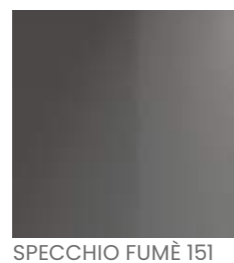

specchio  
fumè

# FRONTALI

telaio alluminio color ferro con  
pannello sp. 3 mm

FRONT PANELS

Aluminum frame colored ferro  
with panel th. 3 mm

FAÇADES

Cadre en aluminium couleur ferro  
avec panneau ep. 3 mm

FRONTEN

Ferrofarbener Aluminiumrahmen  
mit Platte st.3 mm

FRENTES

Marco de aluminio color ferro  
y panel esp. 3 mm



stratificato

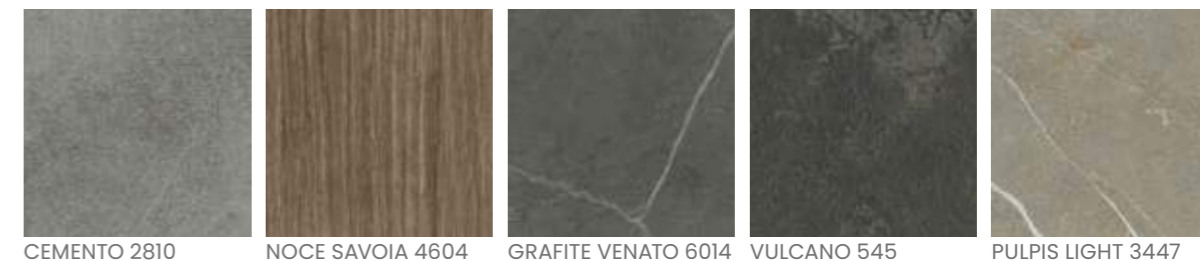

gres

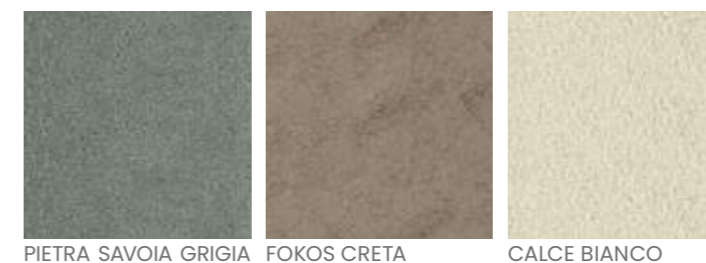



# SCOCCA LACCATA OPACA

Structure matt lacquered - Structure lacquée mat  
Korpus matt lackiert - Estructura lacada mate

BIANCO 01	NUVOLA 58	CENERE 06	KAKI 07	GRAFITE 02	FERRO 03
NERO 04	VANIGLIA 59	JUTA 60	CANAPA 61	LIQUIRIZIA 62	FANGO 63
TERRA 14	CACAO 64	PAPIRO 57	AVENA 56	FIENO 55	GIADA 38
BOSCO 37	PETROLIO 72	NAFTA 75	TURCHESE 74	MENTA 73	PAVONE 71
NEBBIA 39	POLVERE 46	ANICE 49	AVIO 44	BLU MOBY 47	OLTREMARE 48
LINO 19	FINESTRA 08	FARD 54	CIPRIA 53	CARMINIO 29	BORDEAUX 24
ROSSO INDIA 26	AMBRA 16	ZAFFERANO 15	RAL + NCS		
MET. ALLUMINIO 05	MET. ORO 17	MET. TITANIO 09			



ferro  
opaco di serie

FERRO MATT Standard  
FERRO MAT Standard  
FERRO MATT Standard  
FERRO MATE Estándar

CATALOGUE PLANNIG  
**Maurizio Poletto**

DESIGN E A.D.  
**Dario Poles**

GRAPHIC DESIGN CATALOGO  
**Graphosds**

FOTOGRAFIA  
**Gabriotti Fotografi**

FOTOLITO E STAMPA  
**graficheitalprint.it**

**LUGLIO 2022**

Archeda, al fine di migliorare le caratteristiche tecniche e qualitative della sua produzione, si riserva di apportare, anche senza preavviso, tutte le modifiche che si rendessero necessarie.

To improve the technical and the qualitative characteristics of the production, Archeda reserves the right to make all the suitable modifications without previous notice.

A fin daméliorer les caractéristiques techniques et qualitatives de sa production, la société Archeda se réserve le droit d'apporter, même sans preavis, toutes les modifications qui seront jugées nécessaires.

Um technische und qualitative Merkmale der Produktion zu verbessern, behält sich Archeda vor, alle nötige Abänderungen, ohne Avisierungen, vorzunehmen.

Archeda, a fin de mejorar las características técnicas y cualitativas de su producción, se reserva el derecho de aportar, incluso sin previo aviso, todas las modificaciones necesarias.

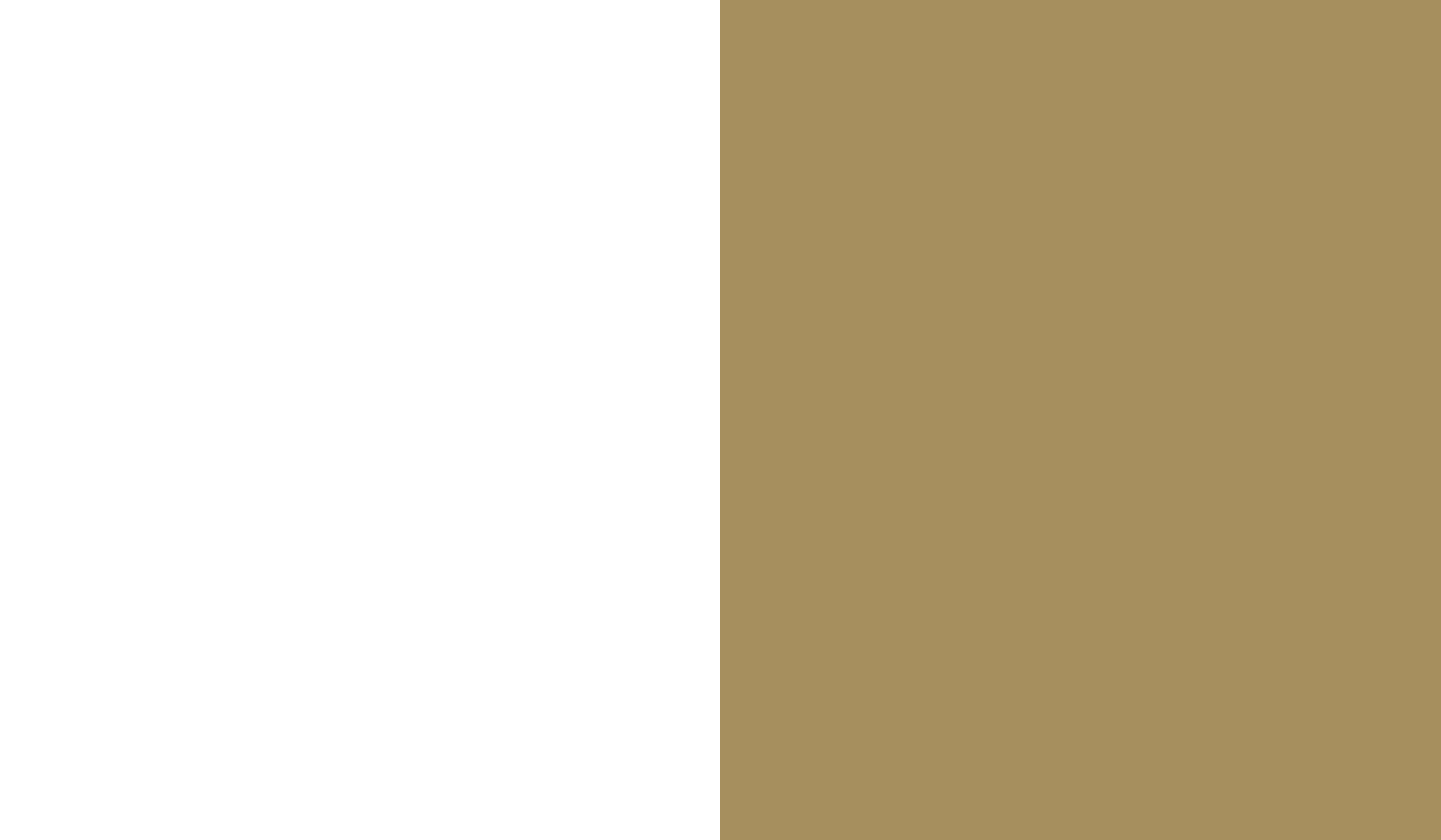



# TULLE CANNETTATO

DESIGN EDITION

# TULLE CANNETTATO

DESIGN EDITION

## RICERCA, DESIGN, INNOVAZIONE E SOSTENIBILITÀ.

L'idea del CANNETTATO, caratterizzato da una superficie rigata a bande verticali, nasce tra gli anni '30 e '50 durante il periodo razionalista e modernista. Oggi torna a vestire mobili e complementi d'arredo, ma con una rivisitazione: aziende e designer lo propongono in diverse sezioni e colorazioni. Noi lo abbiamo pensato a sezione tonda regolare, in finitura noce canaletto e in sei colorazioni su massello di rovere. Questo motivo dà vita ad un flusso morbido di ombreggiature, che si adatta a qualsiasi esigenza.

### RESEARCH, DESIGN, INNOVATION, AND SUSTAINABILITY.

The idea of REEDING a surface, whereby vertical bands are used to create a grooved look, was born between the '30s and '50s during the rationalist and modernist period. Today, it's back adorning furniture and occasionals, but with a new twist: companies and designers are coming up with different cross-sections and colours. Our take on the idea is a regular round cross-section, in a black walnut finish and in six colours on solid oak. This design results in a gently flowing pattern of shade, which fits in well with any interior requirements.

### RECHERCHE, DESIGN, INNOVATION ET DURABILITÉ.

L'idée de la finition NERVURÉE, caractérisée par une surface à nervures verticales, est née entre les années 1930 et 1950, durant la période rationaliste et moderniste. Aujourd'hui, elle a été reprise pour habiller les meubles et les compléments d'ameublement, mais dans un style révisité: les entreprises et les designers la proposent en différentes sections et teintés. Nous, nous l'avons réalisée avec une section ronde régulière et déclinée en noyer noir et en chêne massif dans six différentes tonalités. Ce motif crée un jeu d'ombres doux qui donne du mouvement à la surface et qui s'adapte à tous les besoins.

### FORSCHUNG, DESIGN, INNOVATION UND NACHHALTIGKEIT.

Die Idee der Ausführung CANNETÉ, die sich durch eine senkrecht gerippte Oberfläche auszeichnet, entstand zwischen den 1930er und 1950er Jahren während der Zeit des Rationalismus und der Moderne. Heute ist sie wieder bei Möbeln und Einrichtungsaccessoires zu finden, allerdings in neuem Look: Unternehmen und Designer bieten sie in verschiedenen Formen und Farbtönen an. Wir haben uns für eine Variante mit regelmäßigem rundem Querschnitt entschieden, in Ausführung Nussbaum Canaletto und in sechs Farben bei massivem Eichenholz. Dieses Dekor erzeugt einen weichen Schattenverlauf, der sich allen Erfordernissen anpasst.

### INVESTIGACIÓN, DISEÑO, INNOVACIÓN Y SOSTENIBILIDAD.

La idea del revestimiento ACANALADO, caracterizado por las rayas verticales de su superficie de listones, nace entre los años 30 y 50 durante el período racionalista y modernista. Hoy vuelve a vestir muebles y complementos decorativos, aportando una nueva interpretación: las empresas y los diseñadores lo proponen con diferentes secciones y colores. Nosotros lo hemos concebido con sección redonda regular, en acabado nogal negro y en seis colores distintos en madera maciza de roble. Este motivo da vida a un suave flujo de sombras que se adapta a cualquier necesidad decorativa.

## TULLE CANNETTATO

COMPOSIZIONE **TC01**  
PAG. 04

COMPOSIZIONE **TC02**  
PAG. 16

COMPOSIZIONE **TC03**  
PAG. 30

COMPOSIZIONE **TC04**  
PAG. 38

**FINITURE**  
PAG. 46



## MATERIALI

frontali noce canaletto cannettato  
fianchi noce canaletto  
gola Titanio opaco  
top Seminato Candido Naturale

## ACCESSORI

Lavabo Corner in Seminato Candido Naturale  
specchio Loop  
elementi a giorno Ice in vetro fumè grigio

## TC01

### MATERIALS

noce canaletto cannettato front panels  
noce canaletto sides  
titanio matt groove  
Seminato Candido Naturale top

### ACCESSORIES

Candido naturale Corner washbasin  
loop mirror  
ice gray smoked glass open elements

### MATÉRIAUX

façades noce canaletto cannettato  
côtés terminaux noce canaletto  
gorge structurelle Titanio mat  
P.d.T Seminato Candido Naturale

### ACCESSOIRES

vasque Corner en Seminato Candido Naturale  
miroir loop  
éléments ouvertes Ice en verre fumé gris

### MATERIALIEN

möbelfronten noce canaletto cannettato  
Seitenwänden noce canaletto  
griffprofil titanio matt  
waschtischplatte Seminato Candido Naturale

### ZUBEHÖRE

waschbecken Corner aus Seminato Candido Naturale  
spiegel loop  
Ice offene Elemente in grauem Rauchglas

### MATERIALES

frentes noce canaletto cannettato  
lados de acabado noce canaletto  
ranura titanio mate  
encimera Seminato Candido Naturale

### ACCESORIOS

cuba Corner Seminato Candido Naturale  
espejo loop  
elementos abiertos Ice en vidrio ahumado gris







ARCHEDA TULLE CANNETTATO\_8



ARCHEDA TULLE CANNETTATO\_9



ARCHEDA TULLE CANNETTATO\_10



ARCHEDA TULLE CANNETTATO\_11



## ANTE CANNETTATE

Tulle si arricchisce di una nuova finitura, il CANNETTATO, un'idea capace di soddisfare le richieste più esigenti e di dare valore ad ogni angolo del tuo bagno.

### REEDED DOORS

Tulle now comes in a new finish, REEDED, an idea that successfully caters to even the most exacting demands and adds value to every corner of your bathroom.

### PORTES NERVURÉES

Le modèle TULLE s'enrichit d'une nouvelle finition NERVURÉE, une idée à même de répondre aux requêtes les plus exigeantes et de valoriser chaque angle de votre salle de bains.

### TÜREN CANNÉTÉ

Das Modell Tulle wird durch die neue Oberflächenausführung CANNÉTÉ bereichert, eine Einrichtungsidee, die den anspruchsvollsten Vorstellungen gerecht wird und jede Ecke Ihres Bads noch schöner macht.

### PUERTAS ACANALADAS

Tulle se enriquece con un nuevo acabado, el ACANALADO, una idea capaz de satisfacer la demanda más exigente y de dar valor a cada rincón de tu baño.

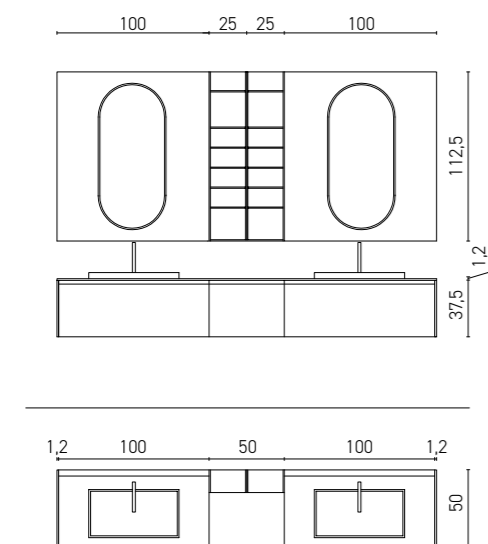



## MATERIALI

frontali rovere fiammato tartufo cannettato e liscio  
fianchi rovere fiammato tartufo  
gola rovere fiammato tartufo  
top Seminato Nero Naturale

## ACCESSORI

vasca integrata GZ15  
specchio goccia  
lampada e mensola vertigo

## TC02

### MATERIALS

tartufo fiammato oak cannettato and smooth front panels  
tartufo fiammato oak sides  
tartufo fiammato oak groove  
Seminato Nero Naturale top

### ACCESSORIES

GZ15 integrated washbasin  
Goccia mirror  
Vertigo lamp and shelf

### MATÉRIAUX

façades chêne Fiammato Tartufo cannettato et lisse  
côtés terminaux chêne Fiammato Tartufo  
gorge structurelle chêne Fiammato Tartufo  
P.d.T Seminato Nero Naturale

### ACCESSOIRES

vasque intégrée GZ15  
miroir goccia  
lampe et étagère Vertigo

### MATERIALIEN

möbelfronten eiche fiammato tartufo cannettato und glatt  
Seitenwänden eiche fiammato tartufo  
griffprofil eiche fiammato tartufo  
waschtischplatte Seminato Nero Naturale

### ZUBEHÖRE

integrierte waschbecken GZ15  
spiegel goccia  
lampe und ablage Vertigo

### MATERIALES

frentes roble fiammato tartufo cannettato e liso  
lados de acabado roble fiammato tartufo  
ranura roble fiammato tartufo  
encimera Seminato Nero Naturale

### ACCESSORIOS

cuba integrada GZ15  
espejo goccia  
lampara y estante vertigo













## MADE IN ITALY

Le nostre creazioni si distinguono per il design, la qualità, la funzionalità. La scelta dei materiali e le lavorazioni di mani esperte a garanzia di un prodotto capace di durare nel tempo.

### MADE IN ITALY

Our creations stand out for their design, quality and function. The carefully selected materials and expert craftsmanship deliver a product destined to stand the test of time.

### MADE IN ITALY

Nos créations se distinguent par leur design, leur qualité et leur fonctionnalité. Le choix des matériaux et les façonnages réalisés par des mains expertes assurent un produit à même de durer dans le temps.

### MADE IN ITALY

Unsere Kreationen heben sich durch Design, Qualität und praktischen Nutzen hervor. Die sorgfältige Wahl der Materialien und die Verarbeitung durch erfahrene Hände ist die beste Garantie für ein hochwertiges und langlebiges Produkt.

### MADE IN ITALY

Nuestras creaciones se distinguen por su diseño, calidad y funcionalidad. La elección de excelentes materiales trabajados por manos expertas garantiza un producto capaz de durar en el tiempo.

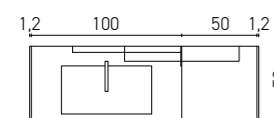
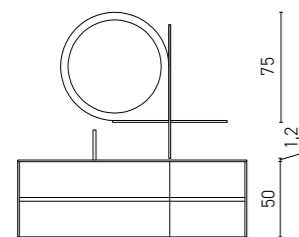



## MATERIALI

frontali rovere fiammato tartufo cannettato  
fianchi rovere fiammato tartufo  
gola Titanio opaco

## ACCESSORI

console box bianco opaco  
specchio loop

## TC03

### MATERIALS

tartufo fiammato oak cannettato front panels  
tartufo fiammato oak sides  
titanio matt groove

### ACCESSORIES

white matt box console  
Loop mirror

### MATÉRIAUX

façades chêne Fiammato Tartufo cannettato  
côtés terminaux chêne Fiammato Tartufo  
gorge structurelle Titanio mat

### ACCESSOIRES

console box blanc mat  
miroir loop

### MATERIALIEN

möbelfronten eiche fiammato tartufo cannettato und glatt  
Seitenwänden eiche fiammato tartufo  
griffprofil eiche titanio matt

### ZUBEHÖRE

mattweiße konsole box  
spiegel loop

### MATERIALES

frentes roble fiammato tartufo  
lados de acabado roble fiammato tartufo  
ranura titanio mate

### ACCESORIOS

cuba box blanca mate  
espejo loop





## BAGNO DI DESIGN

Trend indiscusso il mobile cannettato, che esprime carattere ed eleganza. Se cerchi un bagno di design sei nel posto giusto, TULLE ti offre un'ampia gamma di finiture ed accessori per soddisfare i tuoi desideri.

### DESIGNER BATHROOM

Reeded furniture, exuding character and elegance, is undeniably on-trend right now. If you're looking for a designer bathroom, you've come to the right place: TULLE offers an extensive range of finishes and accessories to meet your every wish.

### SALLE DE BAINS DESIGN

Le meuble à façade nervurée est sans aucun doute extrêmement tendance et apporte du caractère et de l'élégance à l'espace. Si vous cherchez une salle de bains design, vous êtes au bon endroit : le modèle TULLE vous offre une vaste gamme de finitions et d'accessoires qui répondront à tous vos besoins.

### DESIGNBAD

Unbestritten im Trend liegt das Möbelement in Ausführung Canneté, das Charakter und Eleganz zum Ausdruck bringt. Wenn Sie ein Designbad suchen, dann sind Sie hier genau richtig. TULLE bietet Ihnen eine reiche Auswahl an Ausführungen und Zubehörteilen, um alle Ihre Wünsche zu erfüllen.

### BAÑO DE DISEÑO

Tendencia indiscutible, el mueble acanalado transmite carácter y elegancia. Si buscas un baño de diseño, estás en el lugar adecuado: TULLE te ofrece una amplia gama de acabados y accesorios para que puedas cumplir todos tus deseos.

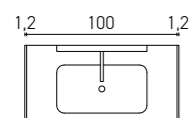
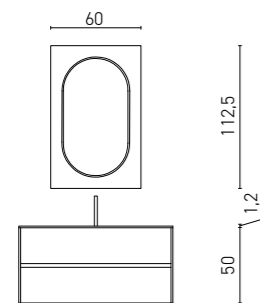



## MATERIALI

frontali noce canaletto cannettato  
fianchi noce canaletto  
gola Titanio opaco  
top Seminato Nero Naturale

## ACCESSORI

vasca integrata GZ15  
specchio Raggio  
lampade Rossini

## TC04

### MATERIALS

noce canaletto cannettato front panels  
noce canaletto sides  
titanio matt groove  
Seminato Nero Naturale top

### ACCESSORIES

GZ15 integrated washbasin  
Raggio mirror  
Rossini lamps

### MATÉRIAUX

façades noce canaletto cannettato  
côtés terminaux noce canaletto  
gorge structurelle Titanio mat  
P.d.T Seminato Nero Naturale

### ACCESSOIRES

vasque intégrée GZ15  
miroir raggio  
lampes rossini

### MATERIALIEN

möbelfronten noce canaletto cannettato  
Seitenwänden noce canaletto  
griffprofil titanio matt  
waschtischplatte Seminato Nero Naturale

### ZUBEHÖRE

integrierte waschbecken GZ15  
spiegel raggio  
lampen Rossini

### MATERIALES

frentes noce canaletto cannettato  
lados de acabado noce canaletto  
ranura titanio mate  
encimera Seminato Nero Naturale

### ACCESSORIOS

cuba integrada GZ15  
espejo raggio  
lamparas rossini







## FORMA ED ELEGANZA

Questa lavorazione esalta i volumi delle ante creando un effetto tridimensionale e di chiaro scuro alternato che ti cattura fin dal primo sguardo. Con gli abbinamenti consigliati potrai ottenere un mobile elegante e allo stesso tempo funzionale.

### FORM AND ELEGANCE

This detailing brings out the doors' volumes, creating a 3D alternating light and shade effect that grabs your attention from the very first glimpse. With the recommended combinations, you can have an elegant and, at the same time, functional unit.

### FORME ET ÉLÉGANCE

Cette finition exalte les volumes des portes en créant un effet tridimensionnel et une alternance de zones claires et sombres qui vous attireront au premier regard. En suivant les associations recommandées, vous obtiendrez un meuble à la fois élégant et fonctionnel.

### FORM UND ELEGANZ

Diese Bearbeitung unterstreicht das Volumen der Türen und erzeugt einen ungewöhnlichen dreidimensionalen Effekt mit Hell-Dunkel-Optik, der den Betrachter sofort in seinen Bann zieht. Dank der empfohlenen Kombinationen können Sie ein elegantes, aber auch sehr zweckmäßiges Möbelement kreieren.

### FORMA Y ELEGANCIA

Este acabado resalta los volúmenes de las puertas creando un efecto de claroscuro alternado y tridimensional que captura a simple vista. Con las combinaciones aconsejadas, podrás obtener un mueble elegante y funcional al mismo tiempo.

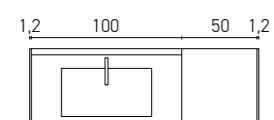
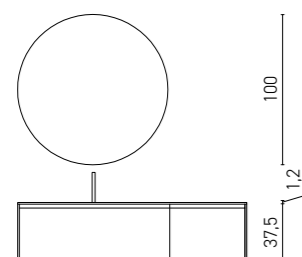

## FINITURE

Un'esclusiva soluzione di antine in multistrato di betulla cannettate in massello di noce canaletto e rovere fiammato in 6 tonalità, da abbinare alla versione liscia delle stesse essenze oppure al laccato opaco. Il nostro amore per i materiali e per i dettagli, ci ha spinti a proporre una serie di soluzioni compositive e cromatiche, per un ambiente bagno raffinato ed elegante, con particolare attenzione all'impatto ambientale.



## FINISHES

An exclusive solution comprising birch plywood doors with solid black walnut and flamed oak reeding in 6 shades, to be paired with the plain version in the same wood finishes or matt lacquered. Our love of materials and details has prompted us to come up with a series of solutions offering plenty of configuration and colour options, for a refined, elegant bathroom interior, with a focus on environmental impact.

## FINITIONS

Une solution unique de portes réalisées en multiplis de bouleau et revêtues de nervures verticales en noyer noir massif ou bien en chêne massif flammé proposé en 6 tonalités au choix, que l'on pourra associer à des portes lisses ou laquées mates. Notre amour pour les matériaux et pour les détails de qualité nous a poussés à proposer une série d'agencements possibles et de solutions chromatiques pour une salle de bains raffinée et élégante, avec un intérêt particulier à l'impact sur l'environnement.

## AUSFÜHRUNGEN

Eine exklusive Lösung für die Türen aus Birken-Mehrschichtholz mit Oberfläche in Ausführung Cannelé aus massivem Nussbaum Canaletto und Eiche geflammt in 6 Farbtönen, die mit der glatten Version der gleichen Holzart oder mit matt lackierten Ausführungen kombiniert werden kann. Unsere Leidenschaft für Materialien und Details hat uns dazu inspiriert, eine Reihe von Anbau- und Farblosungen für ein raffiniertes und elegantes Badezimmer vorzuschlagen, wobei uns die Umweltverträglichkeit besonders am Herzen liegt.

## ACABADOS

Una solución exclusiva de puertas en multicapa de abedul con revestimiento acanalado en madera maciza de nogal negro o roble flameado en 6 tonalidades, para combinar con la versión lisa de las mismas maderas o con el lacado mate. Nuestro amor por los materiales y por el detalle nos ha llevado a proponer una serie de soluciones compositivas y cromáticas destinadas a un ambiente de baño elegante y sofisticado, con una atención especial al impacto ambiental.

ROVERE AGATA

ROVERE CASTAGNA

ROVERE QUARZO

ROVERE CORDA

ROVERE GRANO

ROVERE TARTUFO

NOCE CANALETTO

CATALOGUE PLANNIG  
**Maurizio Poletto**

R. & S.  
**Archeda Srl**

DESIGN E A.D.  
**Dario Poles**

GRAPHIC DESIGN CATALOGO  
**Graphosds**

FOTOGRAFIA  
**Gabriotti Fotografi**

FOTOLITO E STAMPA  
**graficheitalprint.it**

**SETTEMBRE 2022**

Archeda, al fine di migliorare le caratteristiche tecniche e qualitative della sua produzione, si riserva di apportare, anche senza preavviso, tutte le modifiche che si rendessero necessarie.

To improve the technical and the qualitative characteristics of the production, Archeda reserves the right to make all the suitable modifications without previous notice.

A fin daméliorer les caractéristiques techniques et qualitatives de sa production, la société Archeda se réserve le droit d'apporter, même sans preavis, toutes les modifications qui seront jugées nécessaires.

Um technische und qualitative Merkmale der Produktion zu verbessern, behält sich Archeda vor, alle nötige Abänderungen, ohne Avisierungen, vorzunehmen.

Archeda, a fin de mejorar las características técnicas y cualitativas de su producción, se reserva el derecho de aportar, incluso sin previo aviso, todas las modificaciones necesarias.



# ESSENZE

SISTEMA MANIGLIA

# ESSENZE

SISTEMA MANIGLIA



# Essenze

Sono sempre i dettagli a fare la differenza. In questo caso il dettaglio che merita attenzione è proprio la maniglia. Essa è in grado di determinare il carattere e lo stile stesso di un mobile. Oltre alla funzione di aprire e chiudere gli sportelli, la maniglia diventa oggetto di ornamento e personalizzazione. Essenze, inoltre, rinnova la gamma di finiture e decorativi di ante e tops, presenta i nuovi complementi ed accessori, elementi che possono essere utilizzati trasversalmente in tutte le collezioni Archeda.

It's always the details that make the difference. In this case the detail deserving of our attention is the handle which is able to determine the character and style of any piece of furniture. As well as serving to open and close doors, handles are also used to decorate and customise fronts. Moreover, Essenze renews our range of finishes and decorative surfaces for doors and tops and presents new occasional furniture and accessories which can be used across the board with all Archeda collections.

Ce sont toujours les détails qui font la différence. Dans le cas présent, le détail qui attire notre attention est la poignée. Elle est à même de déterminer le caractère et le style d'un meuble. Outre son rôle d'ouverture et de fermeture des portes, la poignée devient un objet de décoration et de personnalisation. En outre, la collection Essenze renouvelle la gamme des finitions et des décoratifs proposée pour les portes et les plans de toilette et présente les nouveaux compléments et accessoires qui peuvent être utilisés transversalement dans toutes les collections Archeda.

Es sind immer die Details, die den großen Unterschied ausmachen. In diesem Fall ist der Griff jenes Detail, das besonders ins Auge fällt, denn er ist in der Lage, den Charakter und den Stil des Möbels zu bestimmen. Er dient nicht nur zum Öffnen und Schließen der Türen, sondern wird zu einem ganz individuellen Dekorelement. Essenze erneuert außerdem das Angebot an Ausführungen und Dekoren für Türen und Abdeckplatten und stellt neue Zubehörteile und Zusatzelemente vor, die raumübergreifend in allen Kollektionen eingesetzt werden können.

Son siempre los detalles lo que marca la diferencia. En este caso, el detalle que merece nuestra atención es el tirador. Esta pieza escapa de determinar el carácter y el estilo de un mueble. Además de servir para abrir y cerrar las puertas, el tirador se convierte en un elemento ornamental que permite personalizar los frentes. Essenze renueva también la gama de acabados y decoraciones de las puertas y encimeras y presenta nuevos complementos y accesorios que pueden utilizarse transversalmente en todas las colecciones Archeda.

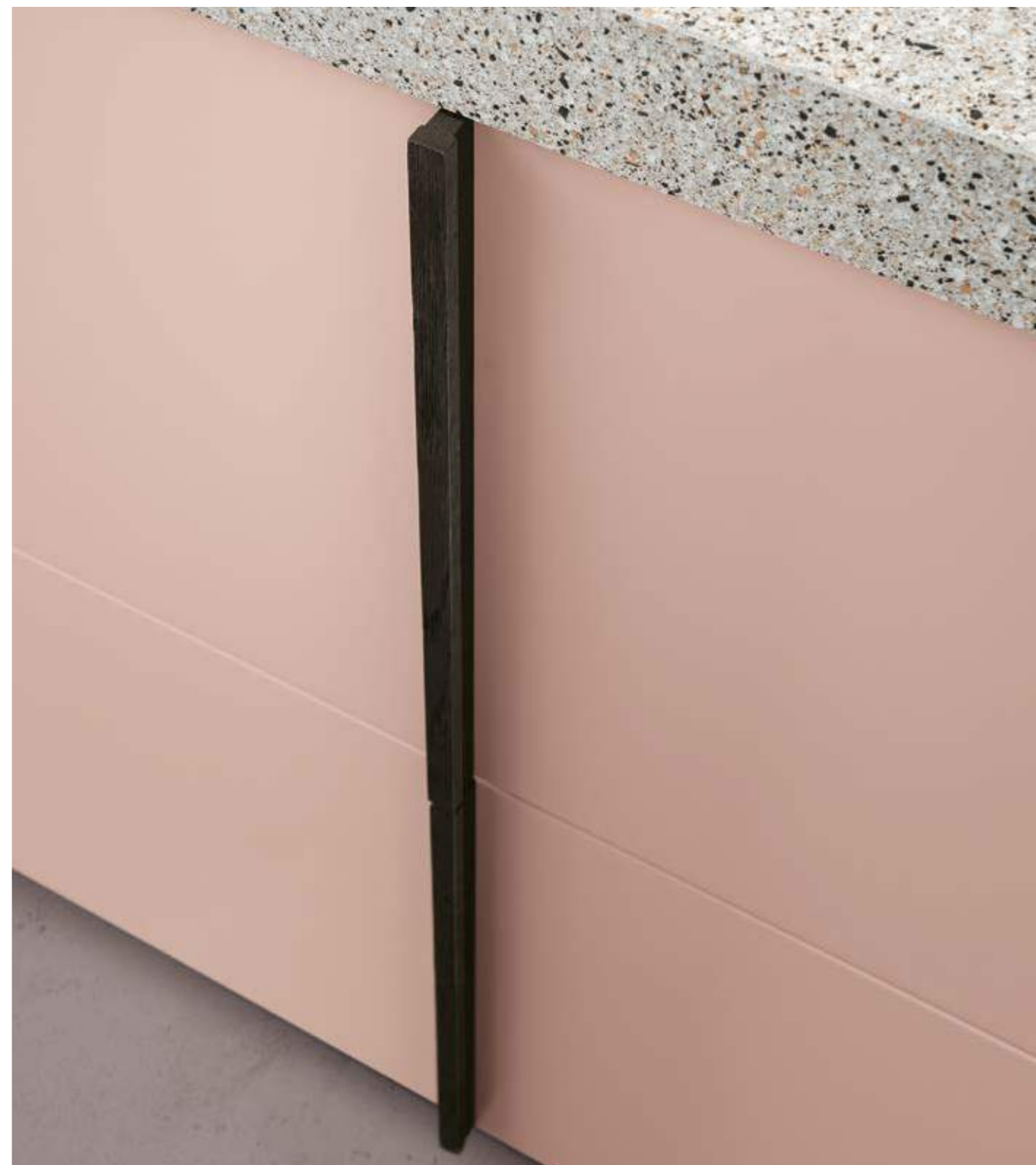

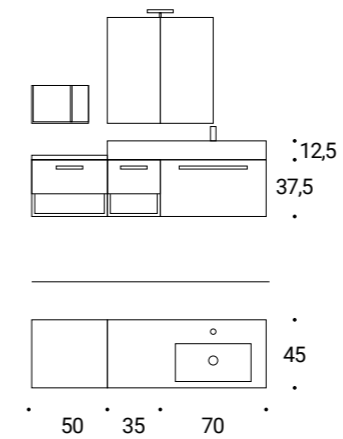

## EsSENze COMPOSIZIONE 01

NORDICO CIOCCOLATO CON MANIGLIA M22 TITANIO - TOP IN GRES WULONG SLATE CON VASCA GF14 - SPECCHIO CONTENITORE CON LAMPADA STELLAR - PENSILE A GIORNO ICE IN VETRO FUMÉ GRIGIO.

**Nordico Cioccolato with handle M22 Titanio. Top in Gres Wulong Slate with integrated sink GF14. Mirror cabinet with lamp Stellar. Wall unit Ice in grey smoked glass.**

**Nordico Cioccolato avec poignée M22 Titanio. Top en Gres Wulong Slate avec vasque intégrée GF14. Armoire de toilette avec lampe Stellar. Élément haut ouvert en verre fumé gris.**

**Nordico Cioccolato mit Griff M22 Titanio. Top Gres Wulong Slate mit Becken GF14. Spiegelschrank mit Lampe Stellar. Ice Hängeschrank aus grauem Rauchglas.**

**Nordico Cioccolato con tiradores M22 Titanio. Encimera de gres Wulong Slate con cuba integrada GF14. Espejo contenedor con lampara Stellar. Elemento abierto Ice de cristal gris ahumado.**

0

1





### CONTENIMENTO

Specchio contenitore e pensile a giorno Ice in vetro fumè, con schiena legno, abbinata alla finitura del mobile. Per un perfetto coordinato.

### STORAGE

Mirror cabinet and Ice open wall unit in smoked glass with wooden back panel matching the finish of the unit. The epitome of coordination.

### RANGEMENT

Armoire de toilette et élément haut ouvert Ice en verre fumé avec fond en bois réalisé dans la même finition que le meuble : un ensemble parfaitement coordonné.

### STAUARAUM

Spiegelschrank und offener Hängeschrank Ice aus Glas Fumè mit Rückwand aus Holz, passend zur Ausführung des Möbelements. Für einen perfekten Gesamteindruck.

### ALMACENAJE

Espejo contenedor y colgante abierto en cristal ahumado Ice con trasera de madera, combinada con el acabado del mueble. Un conjunto perfecto.



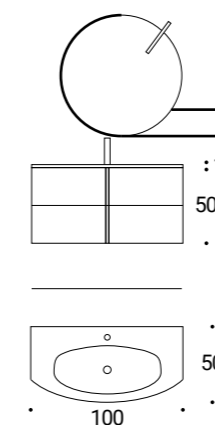

LACCATO  
BIANCO OPACO

LEGNO  
BIANCO

OCRITECH  
BIANCO OPACO

BIMELAMINICO SYNCRO  
MINATO

## EsSENze COMPOSIZIONE 02

LACCATO BIANCO OPACO CON MANIGLIA M31 IN LEGNO BIANCO. - TOP OCRITECH BIANCO OPACO CON VASCA OEE5. - SPECCHIO VIRGOLA ED ELEMENTI A GIORNO IN METALLO BIANCO. - LAMPADA ATLA. - COLONNA COMPOSTA PORTAELETTRODOMESTICI CON VANO PORTA-SCOPE IN FINITURA MINATO.

Matt Bianco lacquered with handle M31 in white wood. Top matt white Ocritech with integrated sink OEE5. Mirror Virgola and white metal elements. Lamp Atla. Column composed of appliance holder with broom compartment in Minato finish.

Laqué Bianco mat avec poignée M31 en bois blanc. Top Ocritech blanc mat avec vasque intégrée OEE5. Miroir Virgola et éléments ouverts en métal blanc. Lampe Atla. Colonne composée porte-appareils électroménagers avec compartiment porte-balai en finition Minato.

Bianco matt lackiert mit Griff M31 Holz weiß. Top Ocritech matt weiß mit integriertem Waschbecken OEE5. Spiegel Virgola und Offenelemente aus weißem Metall. Atla Lampe. Komposithochschrank für Haushaltsgeräte mit Besenkammer in Minato-Ausführung.

Lacado Bianco mate con tiradores M31 de madera Blanco. Encimera de Ocritech blanco mate con cuba integrada OEE5. Espejo Virgola y elementos abiertos de metal blanco. Lampara Atla. Columna compuesta para electrodomésticos con compartimento para escobas en acabado Minato.

0

2





### **FUNZIONALITÀ**

Colonna attrezzata porta lava/asciuga e accessori, per uno spazio multifunzione, che soddisfa le richieste di chi deve realizzare il bagno/lavanderia.

### **FUNCTIONALITY**

Tall unit equipped to house a washer/dryer and accessories, creating a multifunctional space that satisfies the requirements of those intent on furnishing a bathroom/laundry.

### **FONCTIONNALITÉ**

Armoire aménagée pour loger le lave-linge/sèche-linge et divers accessoires afin de créer un espace multifonctionnel répondant aux besoins de ceux qui souhaitent réaliser une salle de bains-buanderie.

### **ZWECKMÄSSIGKEIT**

Ausgestatteter Hochschrank für Waschmaschine/Wäschetrockner und Zubehör, für einen multifunktionellen Raum, der bei Bedarf Badezimmer und Wäscheküche vereint.

### **FUNCIONALIDAD**

Columna equipada para lavadora/secadora y accesorios: un espacio multifuncional que satisface las necesidades de quien debe amueblar el cuarto de baño/lavandería.

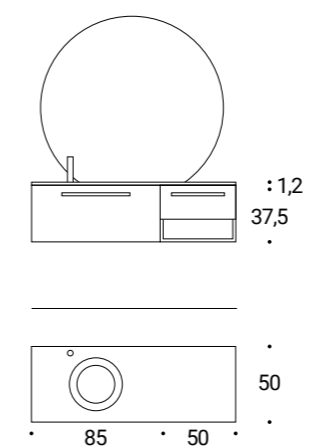

BIMELAMINICO SYNCRO  
SHIBUYA

LACCATO  
FINESTRA OPACO

GEACRYL COLOR MATT  
FINESTRA

## Essenze COMPOSIZIONE 03

SCOCCA FINESTRA OPACO CON FRONTALI SHIBUYA, MANIGLIA M22 TITANIO  
- TOP IN GEACRYL COLOR MATT FINESTRA CON VASCA INTEGRATA LE15 E  
TAVOLETTA IN TINTA - SPECCHIO ALBA CON LAMPADRE ROSSINI - VASCA MILORD  
IN GEACRYL COLOR MATT FINESTRA CON SPECCHI SPUTNIK.

Body matt Finestra lacquered  
with fronts Shibuya, handle  
M22 Titanio.  
Top Geacryl color matt  
Finestra with integrated sink  
LE15 and laundry board.  
Mirror Alba with lamps  
Rossini.  
Bathtub Milord in Geacryl  
color matt Finestra with  
mirror Sputnik.

Structure laquée Matt  
Finestra avec façades  
Shibuya, poignée M22  
Titanio.  
Top Geacryl color matt  
Finestra avec vasque intégrée  
LE15 et planche à linge.  
Miroir Alba avec lampes  
Rossini.  
Baignoire Milord en Geacryl  
color matt Finestra avec  
miroir Sputnik.

Korpus lackiert Matt Finestra  
mit Fronten Shibuya, Griff  
M22 Titanio.  
Top Geacryl color matt  
Finestra mit integriertem  
LE15 Waschbacken und  
Tablett.  
Spiegel Alba mit Lampen  
Rossini.  
Badewanne Milord in Geacryl  
color matt Finestra mit  
Spiegel Sputnik.

Structura lacada Finestra  
mate y frentes en Shibuya,  
tiradores M22 Titanio.  
Encimera de Geacryl color  
matt Finestra con cuba  
integrada LE15 y tableta a  
juego.  
Espejo Alba con lamparas  
Rossini.  
Tina Milord de Geacryl color  
matt Finestra con espejos  
Sputnik.



0

3





#### **PULIZIA FORMALE**

Due semplici e regolari figure geometriche disegnano il nuovo specchio Alba e il nuovo lavabo integrato.

#### **CLEAN-CUT LINES**

Two simple and regular geometric shapes distinguish the new mirror Alba as well as the new integrated washbasin.

#### **FORME ÉPURÉE**

Deux figures géométriques simples et régulières dessinent le nouveau miroir Alba et la nouvelle vasque intégrée.

#### **FORMALE REINHEIT**

Zwei schlichte und regelmäßige geometrische Figuren bilden den neuen Spiegel Alba und das neue integrierte Waschbecken.

#### **LIMPIEZA FORMAL**

Dos figuras geométricas simples y regulares delinear el nuevo espejo Alba y el nuevo lavabo integrado.





#### **ZONA RELAX**

La vasca da bagno è l'oggetto del desiderio per chi vuole rendere l'ambiente bagno un vero e proprio regno del benessere.

#### **AN AREA TO RELAX IN**

The bathtub is the object of desire of those who want to turn the bathroom into a real wellness hub.

#### **ZONE RELAX**

La baignoire est l'objet de convoitise de ceux qui veulent transformer leur salle de bains en un véritable royaume du bien-être.

#### **RELAXZONE**

Die Badewanne ist das Wunschobjekt für alle, die ihr Bad zu einer wahren Wohlfühloase machen möchten.

#### **ZONA RELAX**

La bañera es un objeto del deseo para quien desea transformar el ambiente del baño en un verdadero reino del bienestar.

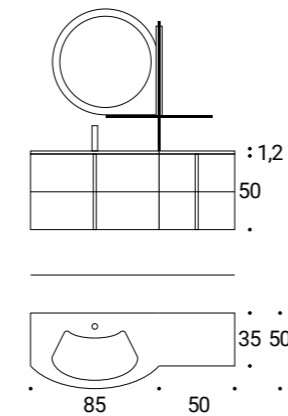

ROVERE FIAMMATO  
AGATA

LEGNO  
CANAPA

DEIMOS STONE  
SABBIA

## Essenze COMPOSIZIONE 04

ROVERE FIAMMATO AGATA CON MANIGLIE M31 IN LEGNO CANAPA - TOP IN DEIMOS STONE SABBIA CON VASCA ACC5 E PILETTA IN TINTA - SPECCHIO GOCCIA CON LAMPADA E MENSOLA VERTIGO - COLONNA CON ANTE IN VETRO FUMÉ GRIGIO E ILLUMINAZIONE INTERNA AFFIANCATA A COLONNA A GIORNO.

Oak Fiammato Agata with handles M31 wood Canapa. Top in Deimos Stone Sabbia with integrated sink ACC5 and drain in the same color. Mirror Goccia with lamp and shelf Vertigo. Column with grey smoked glass doors and internal lighting placed side by side in open column.

Chêne Fiammato Agata avec poignées M31 bois Canapa. Top en Deimos Stone Sabbia avec vasque intégrée ACC5 et bonde dans la même couleur. Miroir Goccia avec lampe et étagère Vertigo. Colonne avec portes en verre fumé gris et éclairage intérieur placé côte à côte dans la colonne ouverte.

Fiammato eiche Agata mit Griffe M31 Holz Canapa. Top in Deimos Stone Sabbia mit integriertem Waschbecken ACC5 und Abfluss in der gleichen Farbe. Spiegel Goccia mit Lampe und Regal Vertigo. Hochschrank mit grauen Rauchglastüren und Innenbeleuchtung nebeneinander in offener Hochschrank platziert.

Roble Fiammato Agata con tiradores M31 de madera Canapa. Encimera de Deimos Stone Sabbia con cuba integrada ACC5 y desagüe a juego. Espejo Goccia con lampara y estante Vertigo. Columna con puertas en cristal gris ahumado y iluminación interna combinada con columna abierta.

0

4





### **CAMBIO DI PROFONDITÀ**

Il mobile curvo si presta ad un utilizzo dove gli spazi e i passaggi sono ridotti, mantenendo un lavabo molto capiente.

### **DIFFERENT DEPTHS**

The curved unit is useful for narrow spaces and places of transit and can be fitted with a very large washbasin.

### **DOUBLE PROFONDEUR**

Le meuble arrondi est parfait pour être installé dans une pièce dont les espaces et les passages sont réduits, tout en disposant d'une vasque avec une grande cuve.

### **TIEFENWECHSEL**

Das geschwungene Möbelement ist die ideale Lösung bei beengten Platzverhältnissen und schmalen Durchgängen und bietet gleichzeitig ein sehr großes Waschbecken.

### **CAMBIO DE PROFUNDIDAD**

El mueble curvo permite utilizar un lavabo muy espacioso en ambientes de dimensiones reducidas.





archeda **essenze**  
PAG. 30

### **MANIGLIE**

Essenze dispone di un'ampia gamma di maniglie, comprese le M16 "listello" orizzontali che seguono la curvatura dei frontali.

### **HANDLES**

Essenze makes a wide range of handles available, including slim horizontal M16 ones that follow the curve of the fronts.

### **POIGNÉES**

Essenze dispose d'une vaste gamme de poignées, y compris les poignées barres horizontales M16 qui suivent l'arrondi des façades.

### **GRIFFE**

Essenze bietet eine reiche Auswahl an Griffen, darunter auch waagrechte „Leisten“ M16, die der Rundung der Fronten folgen.

### **TIRADORES**

Essenze dispone de una amplia gama de tiradores, incluyendo los «listones» horizontales M16 que siguen la curvatura de los frentes.



archeda **essenze**  
PAG. 31

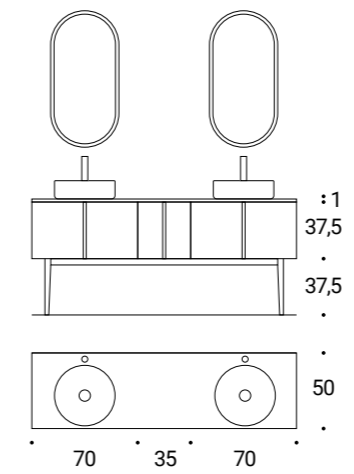

LACCATO  
CANAPA OPACO

LEGNO  
CANAPA

GRES SHILIN  
SLATE

CERAMICA MATT  
TORTORA

## EsSENze COMPOSIZIONE 05

LACCATO CANAPA OPACO CON MAN. M31 IN LEGNO CANAPA - TOP E ALZATINA  
IN GRES SHILIN SLATE CON LAVABI IN APPOGGIO ROUND IN CERAMICA MATT  
TORTORA - SPECCHI LOOP SLIM - PANCA CLIMB IN METALLO TITANIO.

Lacquered matt Canapa with  
handle M31 in wood Canapa.  
Top and backsplash in Gres  
Shilin Slate with washbasins  
Round in matt Tortora  
ceramic.  
Mirrors Loop Slim.  
Bench Climb in Titanium  
metal.

Canapa mat laqué avec  
poignée M31 en bois Canapa.  
Top et dossier en Gres Shilin  
Slate avec vasque Rond en  
céramique Tortora mate.  
Miroirs Loop Slim.  
Banc en métal titane.

Lackiert matt Canapa mit  
Griff M31 in Holz Canapa.  
Top und Backsplash in  
Gres Shilin Schiefer mit  
Waschbecken Round in matt  
Tortora Keramik.  
Spiegel Loop Slim.  
Bench Climb aus Titan-Metall.

Lacado Canapa Mate con  
tiradores M31 de madera  
Canapa.  
Encimera y copete de gres  
Shilin slate con lavabos en  
apoyo Round de cerámica  
matt Tortora.  
Espejos Loop Slim.  
Banquito Climb de metal  
Titanio.



0  
5





#### DETTAGLI

Una ricca gamma di complementi ed accessori studiati per soddisfare le richieste dei clienti più esigenti.

#### DETAILS

We offer an extensive range of occasional furniture and accessories designed to meet the requirements of our most demanding customers.

#### DÉTAILS

Une riche gamme de compléments et d'accessoires étudiés pour satisfaire les demandes des clients les plus exigeants.

#### DETAILS

Ein umfangreiches Angebot an Zusatzelementen und Zubehörteilen, die den Anforderungen der anspruchsvollsten Kunden gerecht werden.

#### DETALLES

Una ricca gama de complementos y accesorios estudiados para satisfacer las necesidades de los clientes más exigentes.



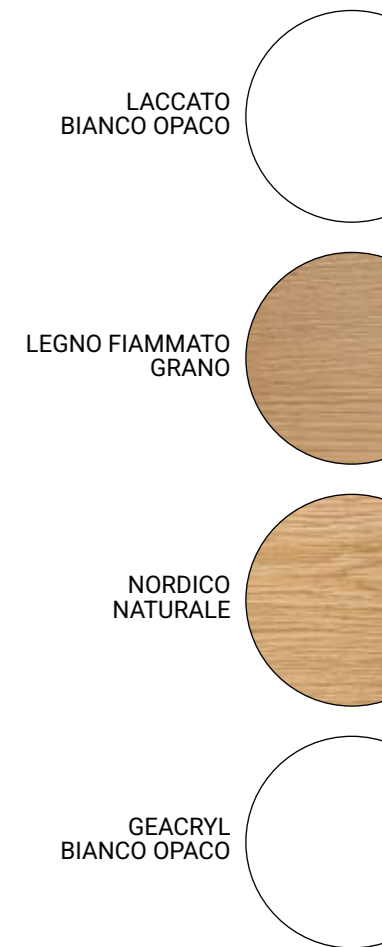
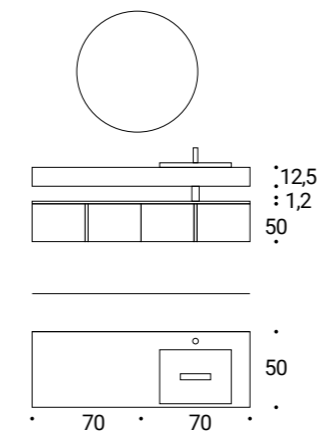

## Essenze COMPOSIZIONE 06

LACCATO BIANCO OPACO CON MAN. M31 IN LEGNO FIAMMATO GRANO - TOP NORDICO NATURALE CON LAVABO SOPRAPIANO IN GEACRYL BIANCO OPACO MOD. BLUES L. 52,5 CM - SPECCHIO RAGGIO CON LAMPADE TUBE BIANCHE.

**Matt Bianco lacquered with handle M31 in wood Fiammato Grano. Top Nordico Naturale with Geacryl matt white washbasin Blues W. 52,5 cm. Mirror Raggio with lamps Tube white.**

**Laqué Bianco mat avec poignée M31 en bois Fiammato Grano. Top Nordico Naturale avec vasque en Geacryl blanc mat mod. Blues L. 52,5 cm. Miroir Raggio avec lampes Tube blanches.**

**Matt Bianco lackiert mit Griff M31 in Holz Fiammato Grano. Top Nordico Naturale mit Geacryl matt weiß Waschbecken Blues B. 52,5 cm. Spiegel Raggio mit Lampen Tube weiß.**

**Lacado Bianco mate con tiradores de madera Fiammato Grano. Encimera de Nordico Naturale con lavabo de incastre en Geacryl blanco mate mod. Blues L. 52,5 cm. Espejo Raggio con lámparas Tube blancas.**

0  
6





### A PORTATA DI MANO

Barra modulare Strike componibile, con porta salviette finale e accessori scorrevoli e riposizionabili. Per un bagno sempre in ordine.

### CLOSE AT HAND

A modular wall bar Strike with a towel rail at the end and sliding accessories that can be moved around at will. For a bathroom that is always tidy.

### À PORTÉE DE LA MAIN

Barre modulaire composable Strike, avec porte-serviettes à l'extrémité et accessoires coulissants s'installant là où on le souhaite. Pour une salle de bains toujours en ordre.

### ALLES IN REICHWEITE

Modulare, zusammensetzbare Schiene Strike mit Handtuchhalter als Endelement und verschiebbaren, abnehmbaren Zubehörteilen. Für ein stets aufgeräumtes Bad.

### AL ALCANCE DE LA MANO

Barra modular componible Strike con toallero final y accesorios deslizantes que se pueden desplazar libremente. Para mantener siempre el orden en el cuarto de baño.



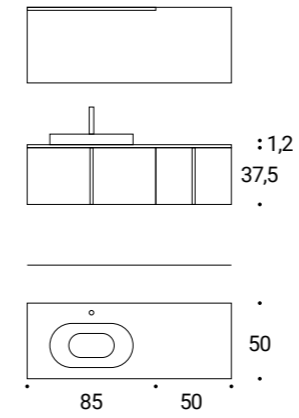

BIMELAMINICO SYNCRO  
PORONOCE LATTE

LEGNO  
FARD

GEACRYL COLOR MATT  
FARD

## EsSENze COMPOSIZIONE 07

PORONOCE LATTE CON MAN. M31 IN LEGNO FARD - TOP E LAVABO SOPRAPIANO  
ROCK IN GEACRYL COLOR MATT FARD - SPECCHIO FILO CON LAMPADA METRO.

Poronocce Latte with handle  
M31 in wood Fard.  
Top and sink Rock in Geacryl  
color matt Fard.  
Mirror Filo with lamp Metro.

Poronocce Latte avec poignée  
M31 en bois Fard.  
Top et vasque Rock en  
Geacryl color matt Fard.  
Miroir Filo avec lampe Metro.

Poronocce Latte mit Griff M31  
aus Holz Fard.  
Top und Waschbecken Rock  
in Geacryl color matt Fard.  
Spiegel Filo mit Lampe Metro.

Poronocce Latte con tiradores  
M31 de madera Fard.  
Encimera y lavabo de  
incastre Rock en Geacryl  
color matt Fard.  
Espejo Filo con lampara Metro.

0

7



### LAVABO ROCK DOWN

Il nuovo lavabo semi incassato dalle forme morbide e arrotondate è personalizzabile con il fondo copri piletta in tinta o bianco.

### WASHBASIN ROCK DOWN

The new inset basin with its softly rounded shape is customisable with matching or white drain cover

### VASQUE ROCK DOWN

La nouvelle vasque semi-encastrée dotée de formes douces et arrondies dispose d'un fond cache-bonde du même couleur ou blanc

### WASCHTISCH ROCK DOWN

Das neue Halbeinbau-Waschbecken mit weicher und abgerundeter Form ist mit einer individuell gestaltbaren Ablaufabdeckung erhältlich, in selbe Farbe oder Weiss.

### LAVABO ROCK DOWN

El nuevo lavabo semiempotrado de formas suaves y redondeadas está personalizable con una tapa para el desagüe a juego o blanca.







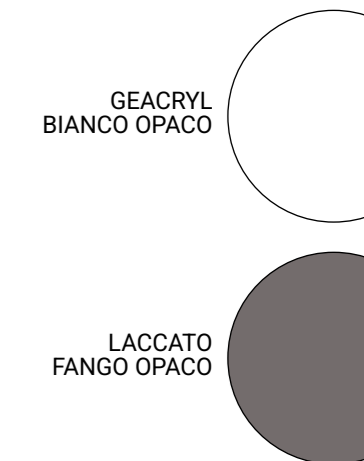
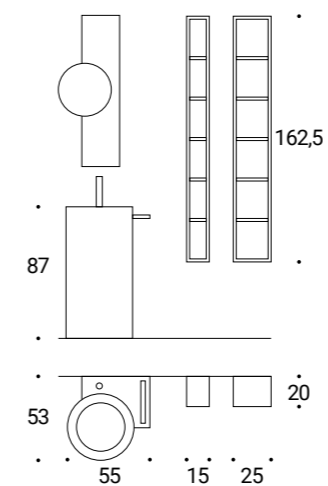

## Esenze COMPOSIZIONE 08

LAVABO POP-ART IN GEACRYL BIANCO OPACO DOTATO DI PIANO D'APPOGGIO LATERALE CON ASOLA PORTA-SALVIETTE - SPECCHIO CONTENITORE POP E COLONNE A GIORNO LACCATI FANGO OPACO - LAMPADE IN METALLO BIANCO MOD. TUBE.

Pop-Art washbasin in matt white Geacryl with side shelf with towel holder.  
Mirror cabinet Pop and open columns lacquered Fango matt.  
White metal lamps mod. Tube.

Lavabo Pop-Art en Geacryl blanc mat avec étagère latérale avec porte-serviettes.  
Armoire de toilette Pop et colonnes ouvertes laquées Fango mat.  
Lampes en metal blanc mod. Tube.

Pop-Art Waschtisch in matt weiß Geacryl mit seitlicher Ablage mit Handtuchhalter.  
Spiegelschrank Pop und offene Hochschränke lackiert Fango matt.  
Weiße Metalllampen mod. Tube.

Lavabo Pop-Art de Geacryl blanco mate con mesita lateral y toallero.  
Espejo contenedor Pop y elementos abiertos lacados Fango mate.  
Lamparas en metal blanco mod. Tube.

0  
8



### SPECCHIO POP

Il nuovo specchio contenitore, con sviluppo verticale è un elemento esclusivo Archeda, molto capiente e si inserisce facilmente in piccoli spazi. Ideale da abbinare al lavabo a colonna.

### MIRROR POP

The new, vertical mirror cabinet is exclusive to Archeda and pairs extensive storage space with an ability to be easily fitted into small spaces. It is a perfect pairing with the cylindrical washbasin.

### MIROIR POP

La nouvelle armoire de toilette à développement vertical est un élément exclusif Archeda, dotée d'une grande contenance et s'installant facilement dans de petits espaces. Idéale pour l'associer à la vasque colonne sur pied.

### SPIEGEL POP

Der neue Spiegelschrank mit senkrechtem Verlauf ist ein Exklusivmodell von Archeda, das sehr viel Stauraum bietet und problemlos in kleine Räume passt. Die ideale Ergänzung zum Säulenwaschtisch.

### ESPEJO POP

El nuevo espejo contenedor con desarrollo vertical es un elemento exclusivo de Archeda que se integra fácilmente en los ambientes más pequeños ofreciendo un amplio espacio de almacenaje. Ideal para combinarlo con el lavabo de columna.



## CILINDRO

La forma del nuovo lavabo a colonna. La variante POP-ART è personalizzata con la pratica tavoletta porta oggetti completa di asola porta salviette.

### CYLINDER

The shape of the new cylindrical washbasin. The POP-ART version is personalized with a practical set-down surface with a towel slot.

### CYLINDRIQUE

Telle est la forme de la nouvelle vasque colonne sur pied. La version POP-ART est personnalisée avec une tablette fonctionnelle dotée d'une fente porte-serviettes.

### ZYLINDRISCH

Die Form des neuen Säulenwaschtischs. Die POP-ART-Version ist mit einer praktischen Ablage mit eingearbeitetem Handtuchhalter individuell gestaltet.

### CILINDRO

La forma del nuevo lavabo de columna. La versión POP-ART está personalizada con una práctica bandeja portaobjetos provista de una ranura para las toallas.



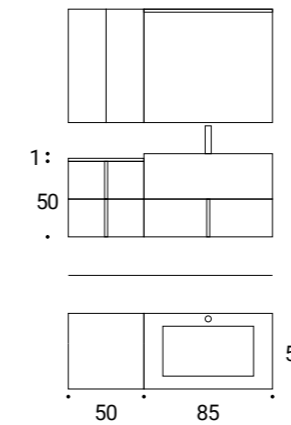

LACCATO  
LUCE OPACO

LEGNO  
LUCE

GRES PIETRA PIASENTINA  
GRIGIO NATURALE

## Essenze COMPOSIZIONE 09

LACCATO LUCE OPACO CON MAN. M31 IN LEGNO LUCE - TOP IN GRES PIETRA PIASENTINA GRIGIO NATURALE CON VASCA GGG5 - SPECCHIO CON PROFILI ALLUMINIO E LAMPADA WALK - COLONNE CON ANTE IN VETRO FUMÉ GRIGIO E ILLUMINAZIONE INTERNA.

Lacquered matt Luce with handle M31 in wood Luce. Top Gres Pietra Piasentina Grigio Naturale with integrated sink GGG5. Mirror with aluminium profiles and lamp Walk. Columns with grey smoked glass doors and interior lighting.

Laqué Luce mat avec poignée M31 en bois Luce. Top Gres Pietra Piasentina Grigio Naturale avec vasque intégrée GGG5. Miroir avec cadre en aluminium et lampe Walk. Colonnes avec portes en verre fumé gris et éclairage intérieur.

Lackiert matt Luce mit Griff M31 aus Holz Luce. Top Gres Pietra Piasentina Grigio Naturale mit integriertem Waschbecken GGG5. Spiegel mit Aluminiumprofilen und Lampe Walk. Hochschrank mit grauen Rauchglastüren und Innenbeleuchtung.

Lacado Luce mate con tiradores M31 de madera Luce. Encimera de gres Pietra Piasentina Grigio Naturale con cuba integrada GGG5. Espejo con perfil de aluminio y lampara Walk. Columnas con puertas en cristal gris ahumado y iluminación interna.

0  
9





**LAVABO GRES**

Il blocco lavabo in gres ospita una capiente vasca, il volume valorizza la composizione non solo a livello estetico ma soprattutto funzionale.

**STONEWARE WASHBASIN**

The stoneware single-block washbasin houses a large bowl; its volume enhances the arrangement both aesthetically and functionally.

**VASQUE EN GRÈS**

Le bloc vasque en grès dispose d'une grande cuve et son grand volume met en valeur la composition non seulement au niveau esthétique, mais surtout au niveau fonctionnel.

**WASCHTISCH AUS GRES**

Der Waschtisch aus Gres besitzt ein geräumiges Becken, die besondere Größe wertet die Zusammenstellung nicht nur aus ästhetischer, sondern vor allem aus funktioneller Sicht auf.

**LAVABO GRES**

El bloque con lavabo de gres aloja una cuba espaciosa: un volumen que resalta tanto el valor estético como funcional de la composición.

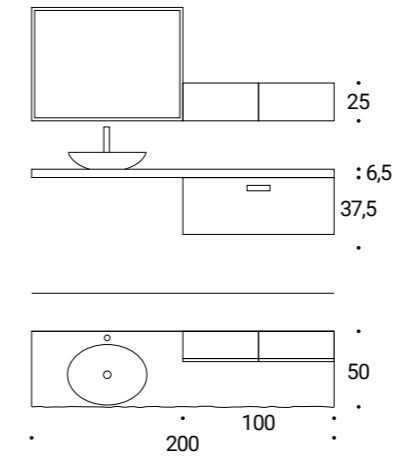

LACCATO  
OLIO OPACO

CORTECCIA  
NATURALE

NERO  
OPACO

## EsSENze COMPOSIZIONE 10

LACCATO OLIO OPACO CON MANIGLIA AD INCASSO M30 TITANIO - TOP  
CORTECCIA NATURALE CON LAVABO IN APPOGGIO SOFTLY NERO OPACO -  
SPECCHIO LUNA AFFIANCATO DA 2 PENSILI CON COPERCHIO RIBASSATO.

Lacquered Matt Olio with  
recessed handle M30 Titano.  
Top Corteccia Naturale with  
sink Softly matt black.  
Mirror Luna flanked by 2 wall  
units with lowered lid.

Laqué Olio Mat avec poignée  
encastrée M30 Titano.  
Top Corteccia Naturale avec  
vasque Softly noir mat.  
Miroir Luna rejoint par  
2 éléments hauts avec  
couvercle abaissé.

Lackiert Matt Olio mit  
versenktem Griff M30  
Titanium.  
Top Corteccia Naturale mit  
Waschbecken Soft matt  
schwarz.  
Spiegel Luna flankiert von  
2 Hängeschränken mit  
abgesenktem Deckel.

Lacado Olio mate con tiradores  
empotrados M30 Titano.  
Encimera de Corteccia  
Naturale con lavabo en apoyo  
Softly negro mate.  
Espejo Luna junto a dos  
colgantes con tapas rebajadas.



1  
0



## CORTECCIA

Porta un pezzo di natura nella tua casa, con i bellissimi piani in rovere massello con bordo corteccia. Pezzo unico per il tuo progetto.

## CORTECCIA

Bring a piece of nature into your home with our beautiful solid oak tops featuring a Corteccia edge and make a unique addition to your project.

## CHANT ÉCORCE

Amenez un morceau de nature dans votre intérieur avec ces splendides plans de toilette en chêne massif avec chant en forme d'écorce.

## CORTECCIA

Holen Sie sich ein Stück Natur in Ihr Heim, mit den wunderschönen Waschtischplatten aus massivem Eichenholz mit Kante in Rindenoptik. Ein wahres Einzelstück für Ihren Badentwurf.

## CORTECCIA

Lleva un trozo de naturaleza a tu casa con los espléndidos tableros de roble maciza con canto Corteccia: una pieza única para tu proyecto.





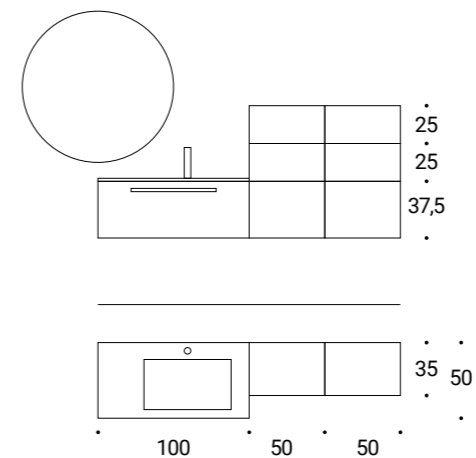

BIMELAMINICO SYNCRO  
MEZZAFIAMMA  
GRIGIO

LACCATO  
GIADA OPACO

GRES AMAZONICO  
SLATE

## EsSENze COMPOSIZIONE 11

BASE PORTA LAVABO CON FRONTALE A "L" IN MEZZAFIAMMA GRIGIO CON MAN. M22 TITANIO E VANO LATERALE A GIORNO LACCATO GIADA OPACO COME LA COMPOSIZIONE DI PENSILI AFFIANCATA - TOP IN GRES AMAZONICO SLATE CON VASCA GZZ5 - SPECCHIO RAGGIO CON LAMPADE TUBE NERE.

Washbasin base with "L" front in Mezzafiamma Grigio grey with handle M22 Titanio and open side compartment matt Giada lacquered as the composition of wall units side by side.  
Top Gres Amazonico Slate with integrated sink GZZ5.  
Miroir Raggio with lamps Tube black.

Élément sous-vasque avec "L" devant Mezzafiamma Grigio gris avec poignée M22 titanio et compartiment latéral ouvert mat Giada laqué comme la composition des éléments hauts côte à côte.  
Top Gres Amazonico Slate avec vasque intégrée GZZ5.  
Miroir Raggio avec lampes Tube noir.

Waschtisch-Us mit front "L" aus Mezzafiamma Grigio Grau mit Griff M22 Titanio und offenem Seitenfach matt Giada lackiert als Komposition der Hängeschränke nebeneinander.  
Top Gres Amazonico Slate mit integriertem Waschbecken GZZ5.  
Spiegel Raggio mit Lampen Tube schwarz.

Mueble lavabo con frente de Mezzafiamma Grigio con tirador M22 Titanio y compartimento abierto lacado Giada mate tales como la composición de colgantes affiancada.  
Encimera de gres Amazonico Slate con cuba integrada GZZ5.  
Espejo Raggio con lamparas negras Tube .

1

1





#### BASE LAVABO

Questo mobile è formato da un sotto lavabo con anta ad "L" che chiude solo parzialmente il vano contenitore laterale, creando un simpatico vano a giorno.

#### WASHBASIN UNIT

The section under the washbasin of this unit features an L-shaped door that gracefully conceals part of the open shelves on the side, leaving them partially exposed.

#### MEUBLE SOUS-VASQUE

Ce meuble sous-vasque dispose d'une façade de tiroir en « L » ne fermant que partiellement le compartiment latéral, en créant ainsi un sympathique élément ouvert.

#### WT-UNTERSCHRANK

Dieses Möbelement besteht aus einem WT-Unterschrank mit „L-förmiger“ Tür, die das seitliche Abteil nur teilweise verdeckt, wodurch ein schönes offenes Fach entsteht.

#### BASE PARA LAVABO

Este mueble está formado por un soporte para el lavabo con puerta en «L» que cierra parcialmente el compartimento de almacenaje lateral creando un simpático compartimento abierto.





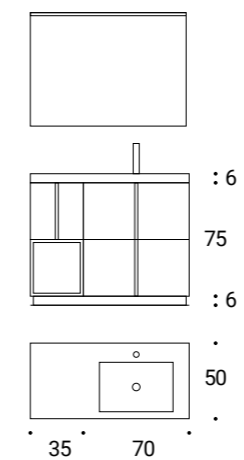

LACCATO  
ROSA QUARZO OPACO

ROVERE FIAMMATO  
TARTUFO

GRES SEMINATO  
CANDIDO

## Essenze COMPOSIZIONE 12

LACCATO ROSA QUARZO OPACO E ROVERE FIAMMATO TARTUFO; MAN. M31 IN LEGNO FIAMMATO TARTUFO - ZOCCOLO LACCATO TITANIO - TOP IN GRES SEMINATO CANDIDO CON VASCA GF15 - SPECCHIO FILO A LED CON LAMPADA METRO - COMPOSIZIONE DI COLONNE CON APERTURA PUSH-PULL.

**Matt Rosa Quarzo and Rovere Fiammato Tartufo; handle M31 in Rovere Fiammato Tartufo. Plinth lacquered Titanio. Top in Gres Seminato Candido with integrated sink GF15. Mirror Filo led with lamp Metro. Composition of columns with push-pull opening.**

**Laqué Rosa Quarzo mat et Rovere Fiammato Tartufo; poignée M31 en Rovere Fiammato Tartufo. Socle laqué Titanio. Top en Gres Seminato Candido avec vasque intégrée GF15. Miroir Filo led avec lampe Metro. Composition de colonnes avec ouverture push-pull.**

**Matt Rosa Quarzo und Rovere Fiammato Tartufo; Griff M31 aus Holz Rovere Fiammato Tartufo. Sockel lackiert Titanio. Top in Gres Seminato Candido mit integriertem Waschbecken GF15. Spiegel Filo mit Lampe Metro. Hängeschränken mit Push-Pullöffnung.**

**Lacado Rosa Quarzo mate y Rovere Fiammato Tartufo; tiradores M31 de madera Fiammato Tartufo. Plinto lacado Titanio. Encimera de gres Seminato Candido con cuba integrada GF15. Espejo Filo con led y lampara Metro. Composición de columnas con push-pull.**



1

2





archeda **essenze**  
PAG. **84**

archeda **essenze**  
PAG. **85**

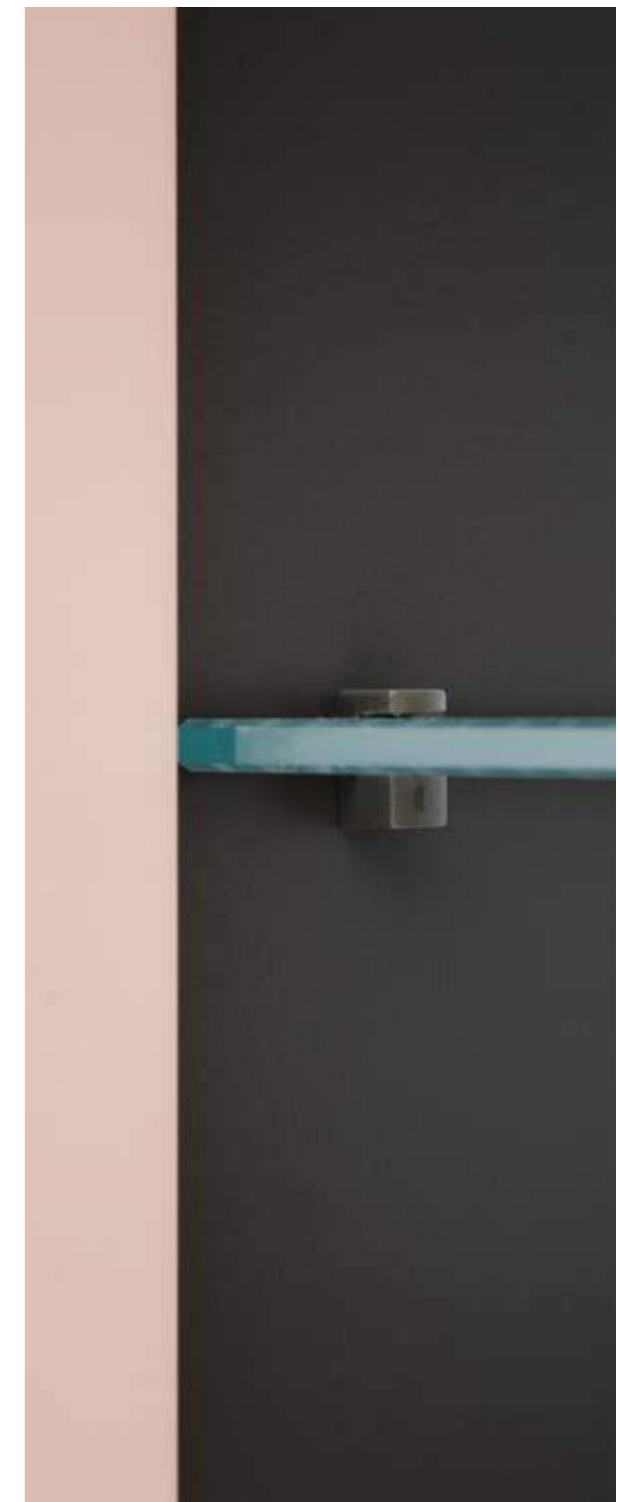
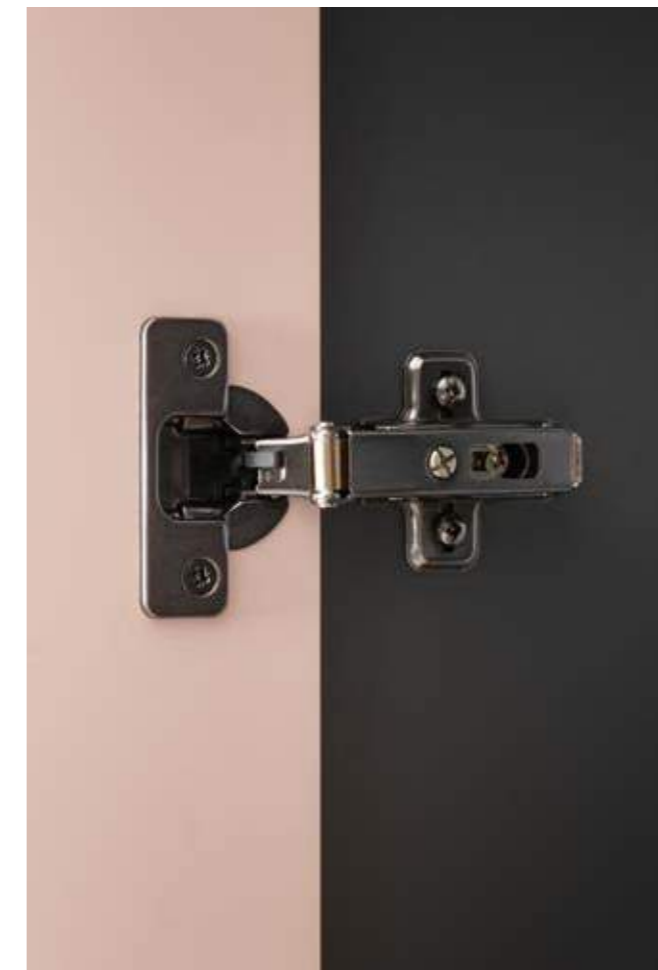



#### **MANIGLIA**

Il dettaglio che merita attenzione è proprio la maniglia in legno. Essa è in grado di determinare il carattere e lo stile stesso del mobile.

#### **HANDLE**

On this arrangement the detail deserving of our attention is the wooden handle which determines its character and style.

#### **POIGNÉE**

La poignée en bois est le détail qui attire notre attention. Elle est à même de déterminer le caractère et le style du meuble.

#### **GRIFFE**

Das Detail, das besonders ins Auge fällt, ist der Griff aus Holz. Er ist in der Lage, den Charakter und den Stil des Möbels zu bestimmen.

#### **TIRADOR**

El detalle que merece nuestra atención es el tirador de madera. Esta pieza es capaz de determinar el carácter y el estilo del mueble.



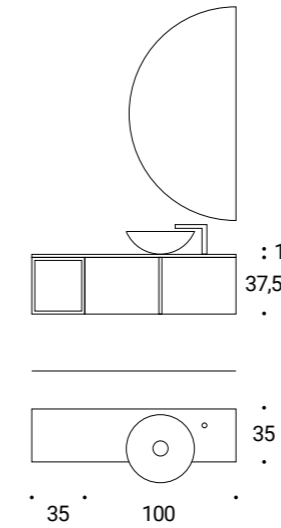

BIMELAMINICO SYNCRO  
PORONOCE  
NAZIONALE



LACCATO  
NERO OPACO



LEGNO  
NERO



GRES  
ARDESIA NERO  
A SPACCO



## Essenze COMPOSIZIONE 13

PORONOCE NAZIONALE E LACCATO NERO OPACO CON MAN. M31 IN LEGNO NERO - TOP IN GRES ARDESIA NERO A SPACCO CON LAVABO IN APPOGGIO FINE 42 NERO OPACO - SPECCHIO SPUTNIK CON LED PERIMETRALI E LAMPADE TUBE NERE.

Poronoce Nazionale and lacquered Nero matt with handle M31 in wood Nero.  
Top in Gres Ardesia Nero a Spacco with sink Fine 42 matt black.  
Mirror Sputnik with perimeter LEDs and lamps Tube black.

Poronoce Nazionale et laqué Nero mat avec poignée M31 en bois Nero.  
Top en Gres Ardesia Nero a Spacco avec vasque Fine 42 noir mat.  
Miroir Sputnik avec éclairage LED périmétrique et lampes Tube noir.

Poronoce Nazionale und lackiert Nero matt mit Griff M31 in Holz Nero.  
Top in Gres Ardesia Nero a Spacco mit Waschbecken Fine 42 matt schwarz.  
Spiegel Sputnik mit Perimeter LEDs und Lampen Tube schwarz.

Poronoce Nazionale y lacado Nero mate con tiradores M31 de madera Nero.  
Encimera de gres Ardesia Nero a Spacco con lavabo en apoyo Fine 42 negro mate.  
Espejo Sputnik con led perimetrales y lamparas negras Tube.

1  
3





archeda **essenze**  
PAG. 92

## ABBINAMENTI

In ogni suo progetto Archeda pone cura e attenzione ad ogni dettaglio, per creare per voi degli spazi accoglienti che rispecchino le vostre esigenze e la vostra personalità.

### PAIRINGS

Archeda carefully curates every detail of each and any project to create inviting spaces just for you that reflect your requirements and your personality.

### ASSOCIATIONS

Dans chacun de ses projets, Archeda accorde un soin et une attention particulière à chaque détail afin de vous créer des espaces accueillants qui reflètent vos besoins et votre personnalité.

### KOMBINATIONEN

Bei allen Entwürfen widmet Archeda jedem einzelnen Detail größtmögliche Aufmerksamkeit, um einladende Räume zu schaffen, die Ihre Bedürfnisse und Ihre Persönlichkeit widerspiegeln.

### COMBINACIONES

Archeda cuida atentamente todos los detalles de sus proyectos para crear espacios acogedores capaces de cumplir vuestras necesidades y de reflejar vuestra personalidad.



archeda **essenze**  
PAG. 93

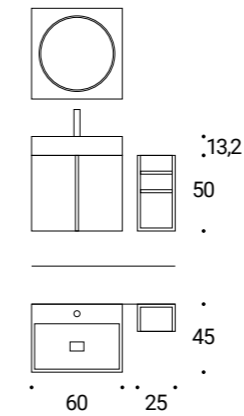

LACCATO  
GRIGIO OPACO

LEGNO  
GRIGIO

## Essenze COMPOSIZIONE 14

LACCATO GRIGIO OPACO CON MAN. M31 IN LEGNO GRIGIO - LAVABO FIGURA  
- SPECCHIO LOOP E PENSILE A GIORNO ICE IN VETRO FUMÉ GRIGIO CON  
SCHIENA LACCATA GRIGIO OPACO.

Matt Grigio lacquered with  
handle M31 in wood Grigio.  
Washbasin Figura, mirror  
Loop and wall unit Ice in  
smoked grey glass with back  
lacquered matt Grigio.

Laqué Grigio mat avec  
poignée M31 en bois Grigio.  
Vasque Figura, miroir Loop et  
élément haut ouvert en verre  
fumé gris avec dos laqué mat  
Grigio.

Matt Grigio lackiert mit Griff  
M31 in Holz Grigio.  
Waschbecken Figura, Spiegel  
Loop und Hängeschrank Ice  
in rauchgrauem Glas mit  
Rückenlack matt Grigio.

Lacado Grigio mate con  
tiradores M31 de madera  
Grigio.  
Lavabo Figura, espejo Loop  
y elemento abierto Ice de  
cristal gris ahumado con  
dorso Grigio mate.

1  
4



**MONOBLOCCO**

Soluzione per piccoli spazi, completo e accessorato. Studiato per essere confortevole e funzionale.

**A SINGLE-BLOCK VANITY UNIT**

A comprehensive and accessorised unit designed for small spaces. Planned to be convenient and functional.

**MONOBLOC**

Une solution pour de petits espaces, complète et accessorisée. Étudiée pour être à la fois confortable et fonctionnelle.

**EINZELEMENT**

Eine vollständige und gut ausgestattete Lösung für kleine Räume. Im Mittelpunkt stehen Benutzerkomfort und Funktionalität.

**MONOBLOQUE**

Solución para pequeños espacios, completo y equipado con accesorios. Estudiado para resultar cómodo y funcional.





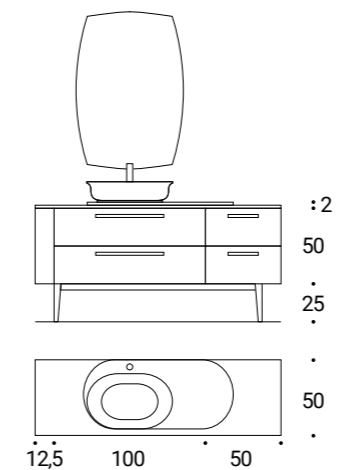

BIMELAMINICO SYNCRO  
PORONOCE  
NAZIONALE

LACCATO  
CANAPA OPACO

## EsSENze COMPOSIZIONE 15

PORONOCE NAZIONALE CON MAN. M22 TITANIO - TERMINALE A GIORNO  
LACCATO CANAPA OPACO - TOP IN PORONOCE NAZIONALE CON LAVABO NICOLE  
E VASSOIO COLORE CANAPA - SPECCHIO VINTAGE CON LED PERIMETRALI E  
LAMPADINE ROSSINI - PANCA CLIMB IN METALLO TITANIO.

Poronoce Nazionale with  
handle M22 Titanio.  
Open-end unit lacquered  
Canapa matt.  
Top in Poronoce Nazionale  
with sink Nicole and tray color  
Canapa.  
Mirror Vintage with perimeter  
LEDs and lamps Rossini.  
Bench in metal Titanio.

Poronoce Nazionale avec  
poignée M22 Titanio. Élément  
terminal ouvert laqué mat  
Canapa.  
Top en Poronoce Nazionale  
avec vasque Nicole et plateau  
couleur Canapa.  
Miroir Vintage avec LED  
périmétral et lampes Rossini.  
Banc en métal Titanio.

Poronoce Nazionale mit Griff  
M22 Titanio.  
Offene Einheit lackiert  
Canapa matt.  
Top in Poronoce Nazionale  
mit Waschbecken Nicole und  
Tablett farbe Canapa.  
Spiegel Vintage mit  
Perimeter LEDs und Lampen  
Rossini.  
Bank aus Metall Titanio.

Poronoce Nazionale con  
tiradores M22 Titanio.  
Módulo terminal abierto  
lacado Canapa mate.  
Encimera de Poronoce  
Nazionale con lavabo Nicole y  
plato en acabado Canapa.  
Espejo Vintage con led  
perimetrales y lamparas  
Rossini.  
Banquito Climbe de metal  
Titanio.

1

5





**VINTAGE**

Una collezione che si adatta a tutti gli stili, in base alla scelta di accessori e materiali. Per una stanza da bagno elegante e raffinata.

**VINTAGE**

A collection that can adapt to any style depending on the accessories and materials chosen. For an elegant and refined bathroom.

**VINTAGE**

Une collection qui s'adapte à tous les styles en fonction du choix des accessoires et des matériaux. Pour une salle de bains élégante et raffinée.

**VINTAGE**

Eine Kollektion, die sich je nach den ausgewählten Zubehörteilen und Materialien an alle Stile anpasst. Für ein elegantes und raffiniertes Badezimmer.

**VINTAGE**

Una colección que se adapta a todos los estilos en función de los accesorios y de los materiales seleccionados. Para un cuarto de baño elegante y exclusivo.



# Maniglie e finiture

Da sempre Archeda porta nelle case i migliori prodotti 100% Made in Italy. Soluzioni di design, realizzate con le migliori materie prime, lavorate all'interno di un ciclo produttivo sostenibile e attento all'ambiente, dallo stile inconfondibile, pensato per essere funzionale e durare nel tempo.

## HANDLES AND FINISHES

Archeda has always brought the best, 100% Made in Italy products to homes. Designer ideas with an unmistakable style, carefully thought out to be functional and long-lasting, constructed using the best raw materials and processed in a sustainable, environmentally-friendly production cycle.

## POIGNÉES ET FINITIONS

Archeda apporte dans les maisons les meilleurs produits 100% Made in Italy et cela depuis toujours. Des solutions design réalisées avec les meilleures matières premières et avec des cycles de fabrication durables et attentifs à l'environnement et dotées d'un style sans égal créé pour être à la fois fonctionnel et pour durer longtemps.

## GRIFFE UND AUSFÜHRUNGEN

Archeda bringt seit jeher die besten Produkte 100% Made in Italy in jedes Heim. Designlösungen, die aus den besten Rohstoffen und in einem nachhaltigen und umweltverträglichen Produktionsprozess hergestellt werden. Sie überzeugen durch unverwechselbaren Stil und sind ganz auf Zweckmäßigkeit und eine lange Lebensdauer ausgerichtet.

## TIRADORES Y ACABADOS

Desde siempre Archeda lleva al hogar los mejores productos 100 % Made in Italy. Soluciones de diseño con un estilo inconfundible, realizadas con las mejores materias primas en el marco de un ciclo productivo sostenible y atento al medioambiente que asegura su funcionalidad y duración a lo largo del tiempo.



## Maniglie

Handles  
Poignées  
Griffe  
Tiradores



M20 BRILL



M21 BIANCO



M22 TITANIO

## Maniglie

Handles  
Poignées  
Griffe  
Tiradores



M29 NICKEL



M30 TITANIO



M16 BRILL



M16 BRILL  
PER BASI CURVE



M16 BRILL  
PORTASALVIETTE PER BASI CURVE



M31  
IN MASSELLO DI ROVERE SPAZZOLATO  
TINTO O LACCATO

## Finiture

Finishes  
Finitions  
Oberflächen  
Acabados

### Laccato opaco/lucido

Matt/gloss lacquered / Laqué mat et brillant  
Matt oder glänzend lackiert / Lacado mate y brillo



\*SOLO OPACO  
MATT ONLY /  
SEULEMENT MAT  
NUR MATT /  
SOLO MATE

archeda **essenze**  
PAG. 108

## Finiture

Finishes  
Finitions  
Oberflächen  
Acabados

### Laccato metal

Metal lacquered / Lacqué Metal  
Metal lackiert / Lacado Metal

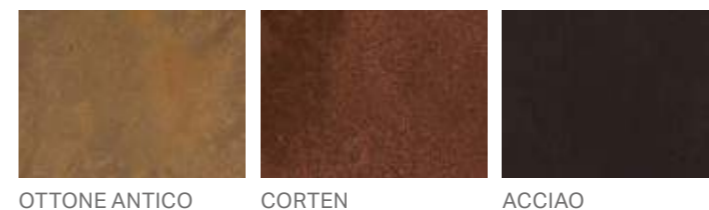

### Bimelaminico skin

Bimelaminated Skin / Bi-mélatiné Skin  
Bimelamin Skin / Bi-melamina Skin



### Bimelaminico syncro

Bimelaminated Syncro / Bi-mélatiné Syncro  
Bimelamin Syncro / Bi-melamina Syncro

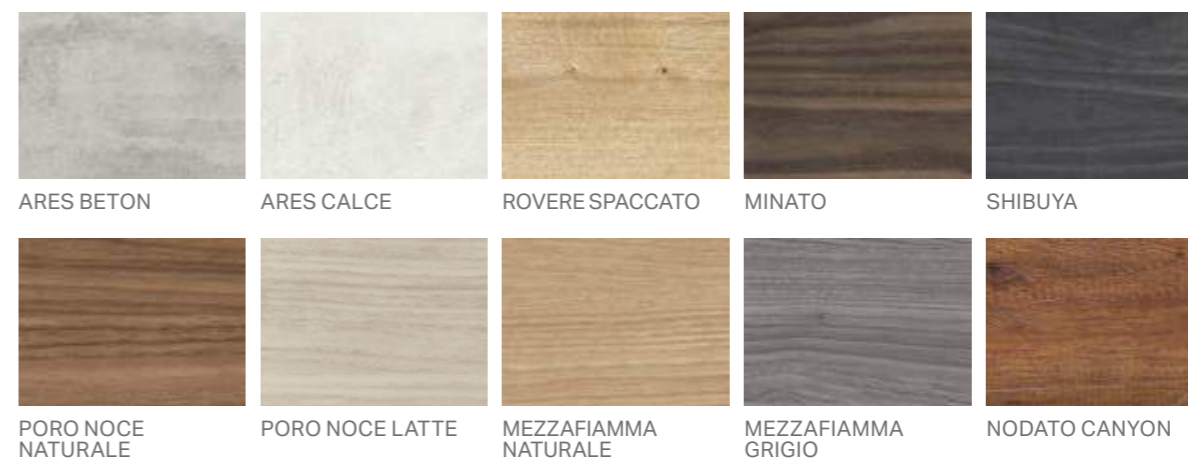

archeda **essenze**  
PAG. 109

## Finiture

Finishes  
Finitions  
Oberflächen  
Acabados

## Legni

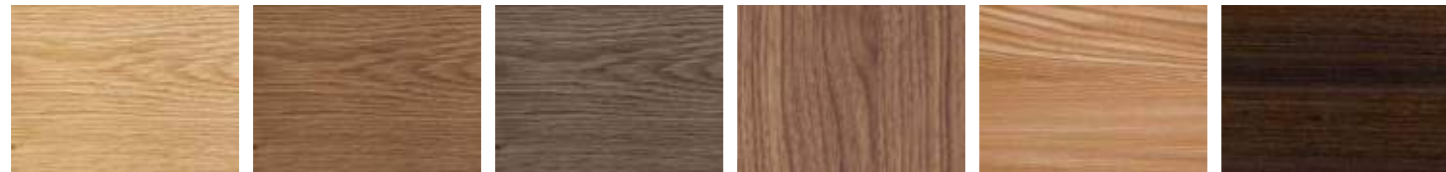

ROVERE NORDICO  
NATURALE

ROVERE NORDICO  
CIOCCOLATO

ROVERE NORDICO  
CAFFÈ

NOCE CANALETTO

OLMO

EUCALIPTO  
AFFUMICATO

## Rovere fiammato decapé

Decapé Fiammato Oak / Chêne Fiammato Decapé  
Decapé Fiammato Eiche / Roble Fiammato Decapé

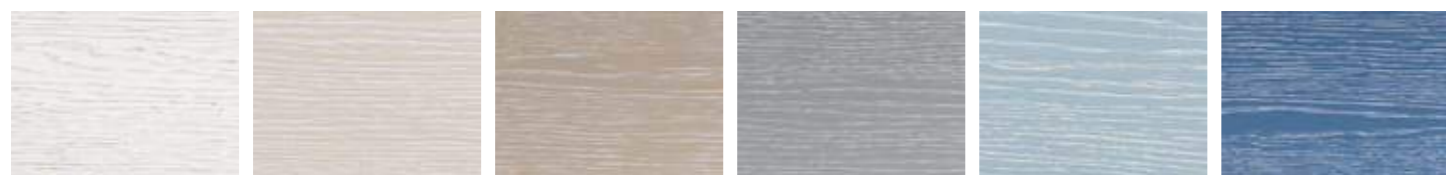

BIANCO PORO SCURO

JUTA PORO BIANCO

CANAPA PORO  
BIANCO

FINESTRA PORO  
BIANCO

POLVERE PORO  
BIANCO

AVIO PORO BIANCO

## Rovere fiammato tinto

Fiammato Oak / Chêne Fiammato Teinté  
Fiammato Eiche / Roble Fiammato

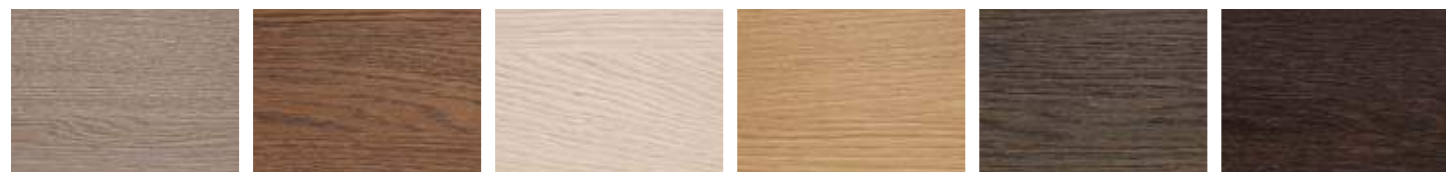

AGATA

CASTAGNA

CORDA

GRANO

QUARZO

TARTUFO

## Terre



PERLESCENTE

MASTICE

OMBRA

ROMA

VITE

## Finiture

Finishes  
Finitions  
Oberflächen  
Acabados

## Hpl unicolor



STATUARIO S. T. 439

CEMENTO 143

OLMO SCURO 303

OLMO BIONDO 134

ROVERE MONET 423

ROVERE TEXAS 306

ROVERE VERSAILLES  
418



ROVERE CASTORO  
301

SASSO 139

BASALTO 403

PORFIDO 119

OSSIDO 146

ARDESIA 145

MALTA BIANCA 430



MALTA GRIGIA 431

MALTA CANAPA 432

ANTIQUE

BOTTICINO 410

CUMA DARK 428

CALYPSO 435

TOBACCO 440



IMPERO 438

## Fenix



GRIGIO  
EFESO 725

VERDE COMODORO  
750

BLU  
FES 754

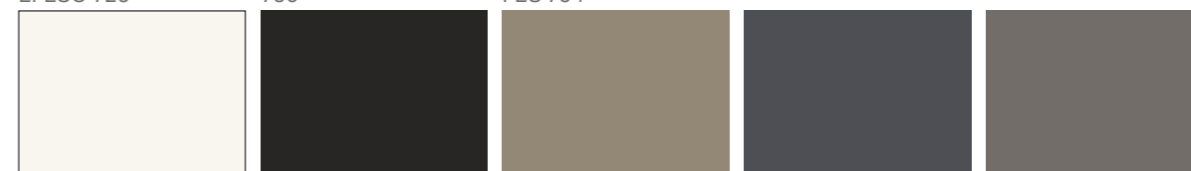

BIANCO 32

NERO 720

BIBER 717

BROMO 724

GRIGIO 718

CATALOGUE PLANNIG  
**Maurizio Poletto**

DESIGN E A.D.  
**Dario Poles**

GRAPHIC DESIGN CATALOGO  
**Graphosds**

FOTOGRAFIA  
**Gabriotti Fotografi**

FOTOLITO E STAMPA  
**graficheitalprint.it**

**SETTEMBRE 2023**

**Archeda, al fine di migliorare le caratteristiche tecniche e qualitative della sua produzione, si riserva di apportare, anche senza preavviso, tutte le modifiche che si rendessero necessarie.**

To improve the technical and the qualitative characteristics of the production, Archeda reserves the right to make all the suitable modifications without previous notice.

Afin d'améliorer les caractéristiques techniques et la qualité de sa production, la société Archeda se réserve le droit d'apporter, même sans préavis, toutes les modifications qu'elle jugera nécessaires.

Um technische und qualitative Merkmale der Produktion zu verbessern, behält sich Archeda vor, alle nötige Abänderungen, ohne Avisierungen, vorzunehmen.

Archeda, a fin de mejorar las características técnicas y cualitativas de su producción, se reserva el derecho de aportar, incluso sin previo aviso, todas las modificaciones necesarias.





# SETA

SISTEMA MANIGLIA

# SETA

SISTEMA MANIGLIA



## IL FASCINO DELLE ANTE A TELAIO.

Moderno ed al contempo tradizionale con richiami shabby chic. Un programma Versatile capace di adattarsi a molteplici esigenze abitative. Si distingue per il design dell'anta a telaio, caratterizzata da una elegante modanatura rientrante che decora il perimetro interno della cornice. Seta è disponibile in tutti i colori laccati opachi, in Bianco lucido e nella versione "passepartout" proposta in 21 diverse combinazioni cromatiche. La collezione è personalizzata da due linee di maniglie, una per la versione moderna e una per la versione classica. Uno stile che appartiene alla nostra storia e tradizione, rivisitato secondo un progetto contemporaneo, che si completa con una serie di nuovi accessori e complementi dedicati.

### EN THE CHARM OF FRAMED DOORS.

Modern yet traditional with a shabby chic appeal, this is a versatile line that can adapt to many home furnishing requirements. It stands out for the design of its framed door featuring an elegant receding moulding that decorates the inner perimeter of the frame. Seta is available in all matt lacquered colors, in Glossy Bianco and in the "passepartout" version presented in 21 different colour combinations. The collection can be customised by two different lines of handles, one for the modern version and one for the classic one. This is a style that belongs to our history and tradition, renewed by a contemporary project that is completed by a set of new specific accessories and pieces of occasional furniture.

### FR LE CHARME DES PORTES À CADRE.

À la fois moderne et traditionnel avec des échos Shabby chic. Un programme polyvalent à même de s'adapter aux multiples besoins d'une habitation. Il se distingue par le design de la porte à cadre dotée d'une élégante moulure rentrante qui décore le pourtour intérieur du cadre. Le modèle Seta est décliné dans toutes les coloris laquées mats, en Bianco Brillant et dans la version "passepartout" présentée en 21 combinaisons de couleurs différentes. La collection est personnalisée par deux lignes de poignées : une pour la version moderne et une pour la version classique. Un style qui appartient à notre histoire et à notre tradition, revisité selon un projet contemporain que l'on pourra agencer avec une série de nouveaux accessoires et compléments dédiés.

### DE DER GANZE CHARME DER RAHMENTÜREN.

Modern und dennoch traditionell mit einem Hauch Shabby Chic. Ein vielseitiges Programm, das sich an zahlreiche Wohnbedürfnisse anpassen lässt. Es sticht durch das Design der Rahmentür hervor, die sich durch eine elegante Vertiefung auszeichnet, die den inneren Rand des Rahmens schmückt. Seta ist in allen matten lackierten Farben, in glänzend Bianco und in der "Passepartout"-Version in 21 verschiedenen Farbkombinationen lieferbar. Die Kollektion verfügt über zwei Grifflinien, eine für die moderne und eine für die klassische Türversion. Ein Stil, der Teil unserer Geschichte und unserer Tradition ist und nun durch einen zeitgemäßen Entwurf neu interpretiert wird. Eine Reihe neuer Zubehörteile und Zusatzelemente vervollständigen das Programm.

### ES EL ENCANTO DE LAS PUERTAS ENMARCADAS.

Moderno y tradicional al mismo tiempo, con un toque shabby chic. Un programa versátil capaz de adaptarse a un sinfín de necesidades. Destaca por su diseño de puerta enmarcada, caracterizada por una elegante moldura empotrada que decora el perímetro interior del marco. El modelo Seta está disponible en todos los colores lacados mate, en Bianco Brillante y en la versión "passepartout" presentada en 21 combinaciones cromáticas diferentes. La colección se personaliza con dos líneas de tiradores, una para la versión moderna y otra para la versión clásica. Un estilo que pertenece a nuestra historia y tradición, revisitado en función de un diseño contemporáneo, que se completa con una serie de nuevos accesorios y complementos dedicados.



L'obiettivo di un **designer** è ascoltare, osservare, capire, empatizzare, sintetizzare e raccogliere intuizioni che gli permettono di rendere visibile l'invisibile.  
(Hillman Curtis)

MODELLO **SETA**  
COMP. **S01**









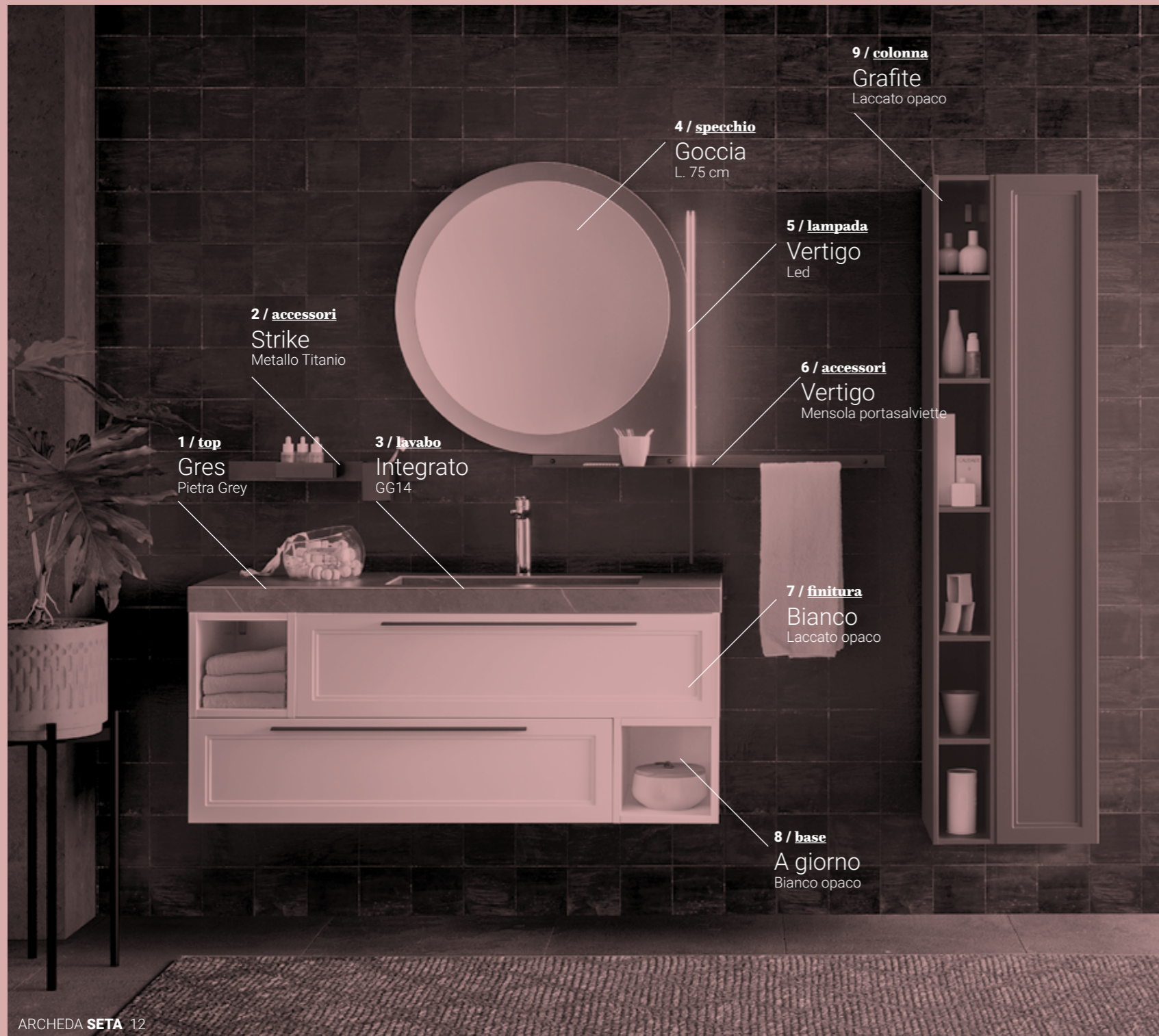

**1 / top**  
Gres  
Pietra Grey

**2 / accessori**  
Strike  
Metallo Titanio

**3 / lavabo**  
Integrato  
GG14

**4 / specchio**  
Goccia  
L. 75 cm

**7 / finitura**  
Bianco  
Laccato opaco

**8 / base**  
A giorno  
Bianco opaco

**6 / accessori**  
Vertigo  
Mensola portasalviette

**5 / lampada**  
Vertigo  
Led

**9 / colonna**  
Grafite  
Laccato opaco

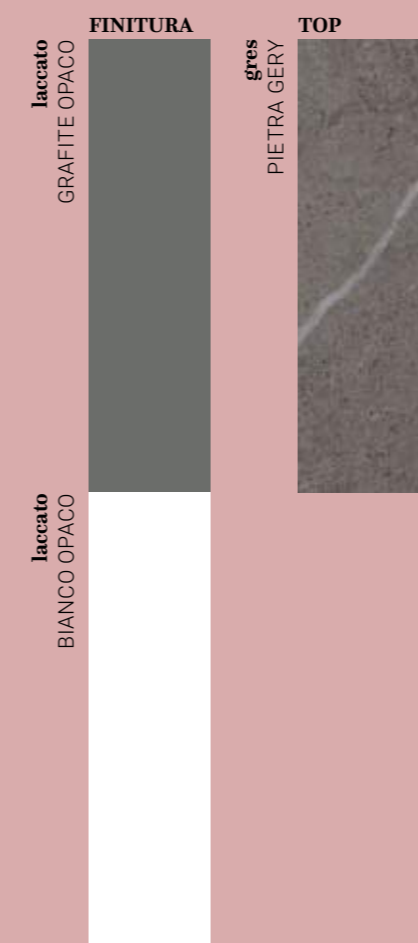
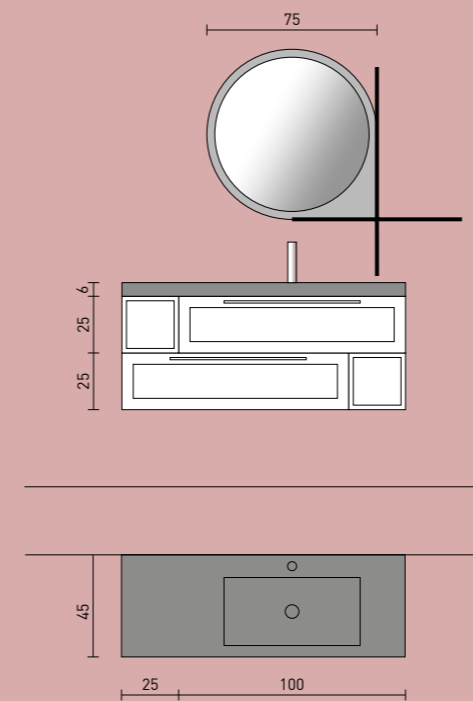

**\_ 1**  
**Top gres Pietra grey sp. 6 cm**  
EN Th. 6 cm Pietra Grey gres top  
FR Pd T. en gres Pietra grey ep. 6 cm  
DE Waschtischplatte aus Gres Pietra grey st. 6 cm  
ES Encimera de Gres Pietra grey esp. 6 cm

**\_ 2**  
**Accessori Strike in metallo Titanio**  
EN Titanio metal Strike accessories  
FR Accessoires Strike en métal Titanio  
DE Accessoires Strike aus Titanio Metall  
ES Accesorios Strike de metal Titanio

**\_ 3**  
**Vasca integrata GG14**  
EN GG14 integrated washbasin  
FR Vasque intégrée GG14  
DE Integrierte Waschbecken GG14  
ES Cuba integrada GG14

**\_ 4**  
**Specchio Goccia con cornice fumè grigio**  
EN Goccia mirror with smoked grey side segment  
FR Miroir Goccia avec cadre fumé gris  
DE Goccia Spiegel mit grau geräuchertem Rahmen  
ES Espejo Goccia con marco gris ahumado

**\_ 5**  
**Lampada a led Vertigo in metallo Titanio**  
EN Titanio metal Vertigo led lamp  
FR Lampe à Led Vertigo en métal Titanio  
DE Vertigo Led-Lampe aus Titanio Metall  
ES Lámpara Led Vertigo en metal Titanio

**\_ 6**  
**Mensola Vertigo in metallo Titanio con portasalviette**  
EN Titanio metal Vertigo shelf with towel holder  
FR Étagère Vertigo en métal Titanio avec porte-serviettes  
DE Vertigo-Regal aus Titanio Metall mit Handtuchhalter  
ES Estante Vertigo de metal Titanio con toallero

**\_ 7**  
**Basi laccate Bianco opaco**  
EN Bianco matt lacquered base units  
FR Elements bas lacquées Bianco mat  
DE Matt Bianco lackierte Unterschränke  
ES Muebles bajos lacados Bianco mate

**\_ 8**  
**Basi a giorno laccate Bianco opaco**  
EN Bianco matt lacquered open base units  
FR Elements bas ouvertes lacquées Bianco mat  
DE Matt Bianco lackierte offene Unterschränke  
ES Muebles bajos abiertos lacados Bianco mate

**\_ 9**  
**Colonna ed elemento a giorno laccati Grafite opaco**  
EN Grafite matt lacquered Tall unit and open element  
FR Colonne et element ouvert lacqués Grafite mat  
DE Hochschrank und offenes Element in mattem Grafite lackiert  
ES Columna y elemento abierto lacado Grafite mate



Se ritieni che un buon **design** sia costoso, dovresti considerare il costo di un cattivo **design**.

(Ralf Speth)

MODELLO **SETA**  
COMP. **S02**







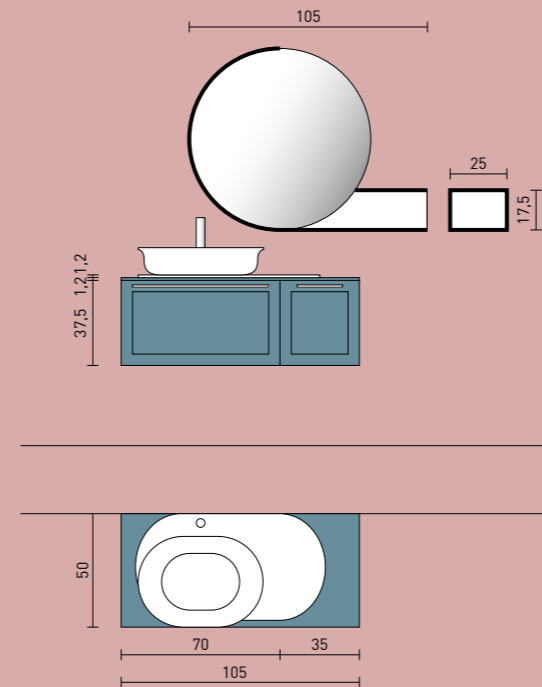
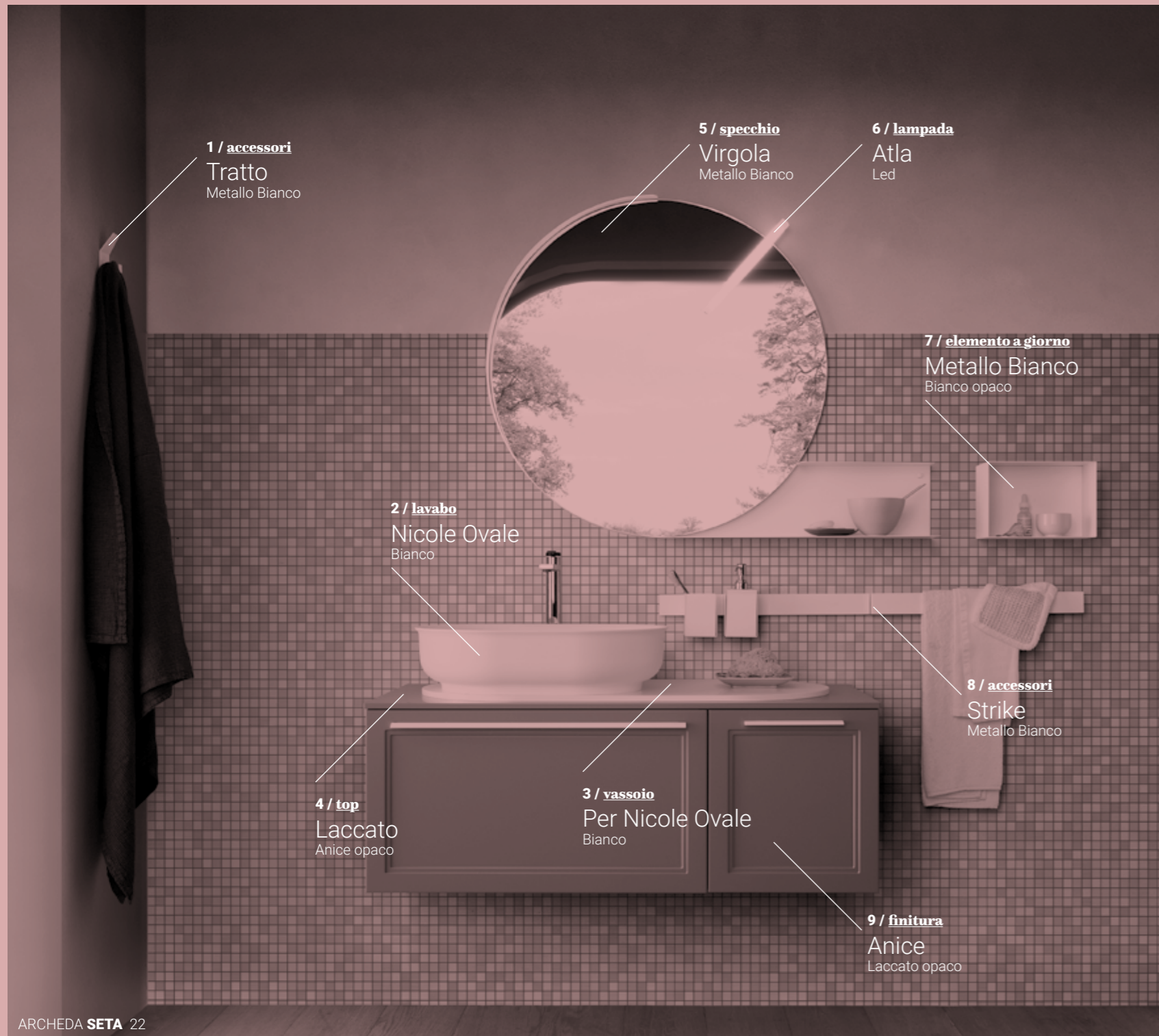

**\_ 1**  
**Appendino Tratto in metallo Bianco**  
EN White metal Tratto hook  
FR Cintre Tratto en métal Bianco  
DE Weißer Metallhaken Tratto  
ES Gancho Tratto de metal blanco

**\_ 5**  
**Specchio Virgola in metallo bianco**  
EN White metal Virgola mirror  
FR Miroir Virgola en métal Blanc  
DE Virgola Spiegel aus weißem Metall  
ES Espejo Virgola de metal blanco

**\_ 9**  
**Basi laccate Anice opaco**  
EN Anice matt lacquered base units  
FR Éléments bas lacqués Anice mat  
DE Matt Anice lackierte Unterschränke  
ES Muebles bajos lacados Anice mate

**\_ 2**  
**Lavabo Nicole Ovale bianco**  
EN Bianco Nicole Ovale washbasin  
FR Vasque Nicole Ovale Bianco  
DE Waschbecken Nicole Ovale Bianco  
ES Lavabo Nicole Ovale Bianco

**\_ 6**  
**Lampada a led Atla**  
EN Atla led lamp  
FR Lampe à Led Atla  
DE Led-Lampe Atla  
ES Lámpara led Atla

**\_ 3**  
**Vassoio bianco per lavabo Nicole Ovale**  
EN Bianco tray for Nicole Ovale basin  
FR Plateau Bianco pour vasque Nicole Ovale  
DE Tablett für Waschbecken Nicole Ovale Bianco  
ES Bandeja para lavabo Nicole Ovale Bianco

**\_ 7**  
**Elemento a giorno in metallo Bianco con retro bianco opaco**  
EN White metal open element with Bianco matt back  
FR Élément ouvert en métal Blanc avec dos Bianco mat  
DE Offenes Element aus weißem Metall mit matt Bianco Rückseite  
ES Elemento abierto de metal blanco con fondo Bianco mate

**\_ 4**  
**Top sp.1,2 cm laccato Anice opaco**  
EN Th.1,2 cm Anice matt lacquered top  
FR Pd.T. ep.1,2 cm lacqué Anice mat  
DE Waschtischplatte lackierte Anice matt st.1,2 cm  
ES Encimera lacada Anice mate esp.1,2 cm

**\_ 8**  
**Accessori Strike in metallo Bianco**  
EN White metal Strike accessories  
FR Accessoires Strike en métal blanc  
DE Accessoires Strike aus weißem Metall  
ES Accesorios Strike de metal blanco



Il buon **design** è visivamente potente, intellettualmente elegante e, soprattutto, senza tempo.

(Massimo Vignelli)

MODELLO **SETA**  
COMP. **S03**









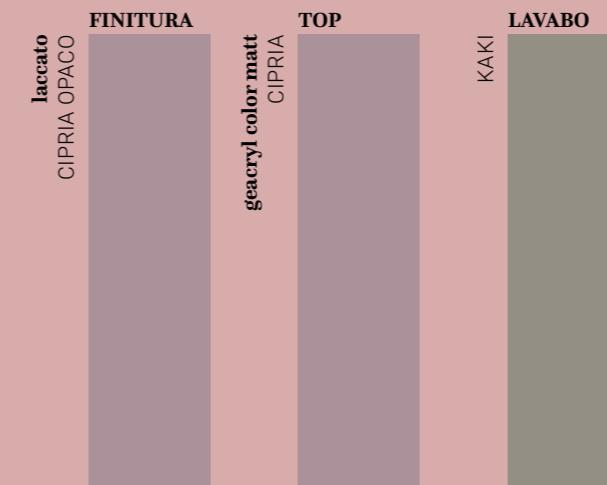
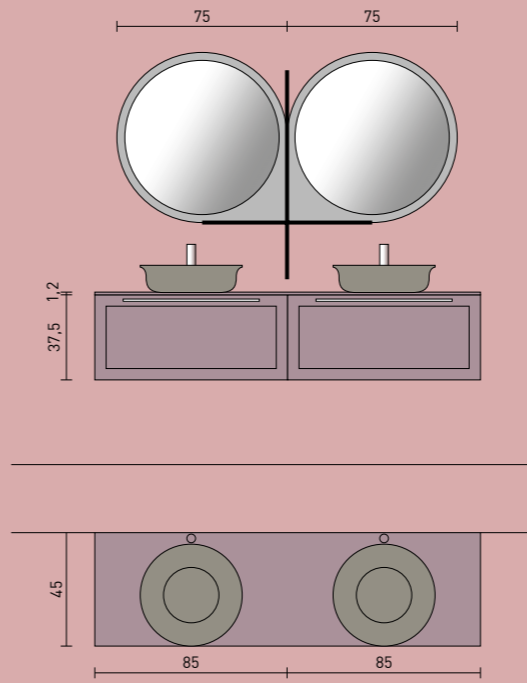
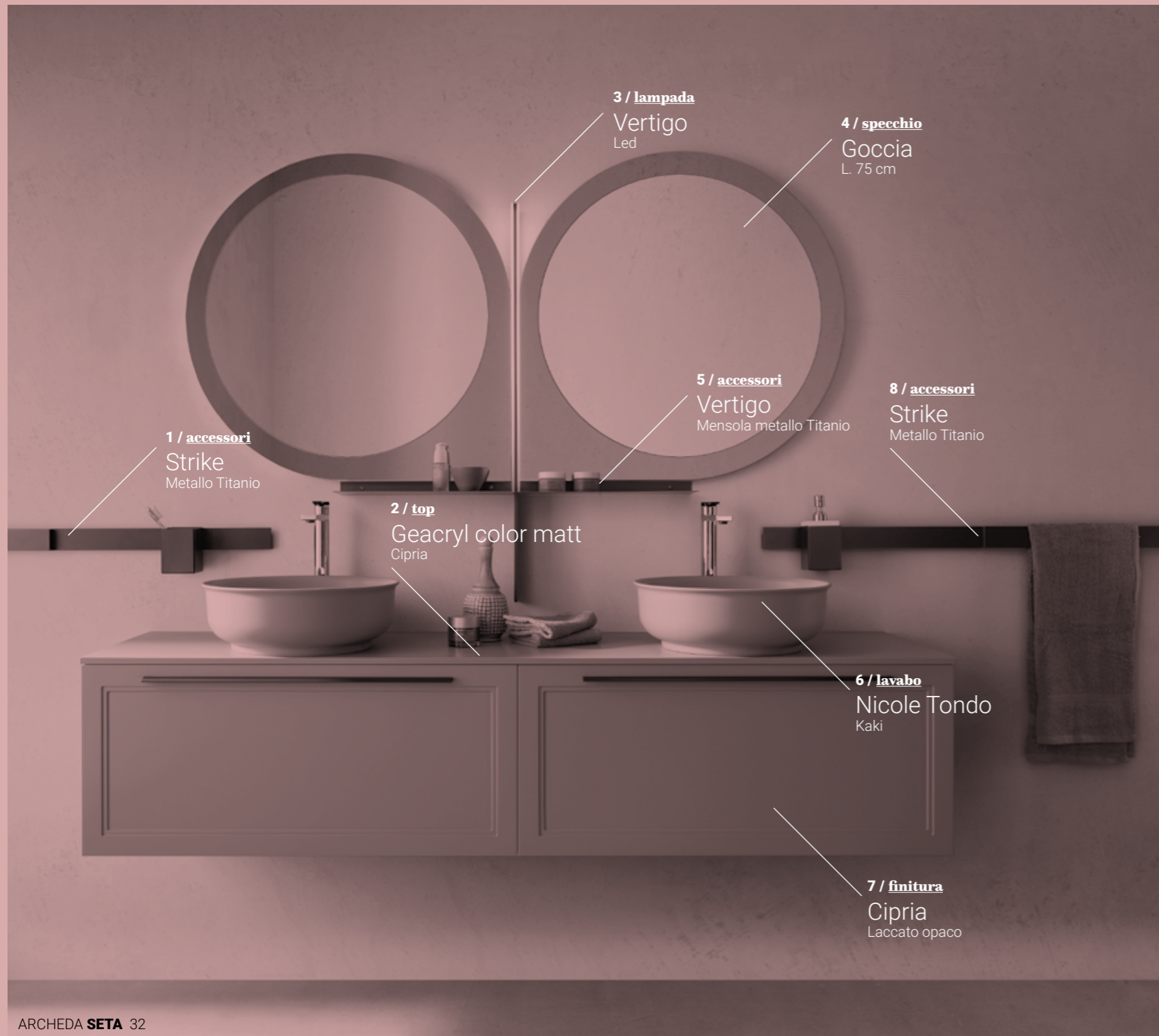

**\_ 1**  
**Accessori Strike in metallo Titanio**

**EN** Titanio metal Strike accessories  
**FR** Accessoires Strike en métal Titanio  
**DE** Accessoires Strike aus Titanio Metall  
**ES** Accesorios Strike de metal Titanio

**\_ 2**  
**Top Geacryl color Matt Cipria sp. 1,2 cm**

**EN** Th.1,2 cm Geacryl color Matt Cipria top  
**FR** P.d T. en Geacryl color Matt Cipria ep.1,2 cm  
**DE** Waschtischplatte aus Geacryl color Matt Cipria st.1,2 cm  
**ES** Encimera de Geacryl color Matt Cipria esp.1,2 cm

**\_ 3**  
**Lampada a led Vertigo in metallo Titanio**

**EN** Titanio metal Vertigo led lamp  
**FR** Lampe à led Vertigo en métal Titanio  
**DE** Vertigo Led-Lampe aus Titanio Metall  
**ES** Lámpara Led Vertigo en metal Titanio

**\_ 4**  
**Specchio Goccia con cornice fumè grigio**

**EN** Goccia mirror with smoked grey side segment  
**FR** Miroir Goccia avec cadre fumé gris  
**DE** Goccia Spiegel mit grau geräuchertem Rahmen  
**ES** Espejo Goccia con marco gris ahumado

**\_ 5**  
**Mensola Vertigo in metallo Titanio**

**EN** Titanio metal Vertigo shelf  
**FR** Étagère Vertigo en métal Titanio  
**DE** Vertigo-Regal aus Titanio Metall  
**ES** Estante Vertigo de metal Titanio

**\_ 6**  
**Lavabo Nicole Tondo Kaki**

**EN** Kaki Nicole Tondo washbasin  
**FR** Vasque Nicole tondo Kaki  
**DE** Waschbecken Nicole Tondo Kaki  
**ES** Lavabo Nicole Tondo Kaki

**\_ 7**  
**Basi laccate Cipria Opaco**

**EN** Cipria matt lacquered base units  
**FR** Éléments bas lacqués Cipria mat  
**DE** Matt Cipria lackierte Unterschränke  
**ES** Muebles bajos lacados Cipria mate

**\_ 8**  
**Accessori Strike in metallo Titanio**

**EN** Titanio metal Strike accessories  
**FR** Accessoires Strike en métal Titanio  
**DE** Accessoires Strike aus Titanio Metall  
**ES** Accesorios Strike de metal Titanio



Il **design** è così  
semplice. Ecco perché è  
così complicato.

(Paul Rand)

MODELLO **SETA**  
COMP. **S04**







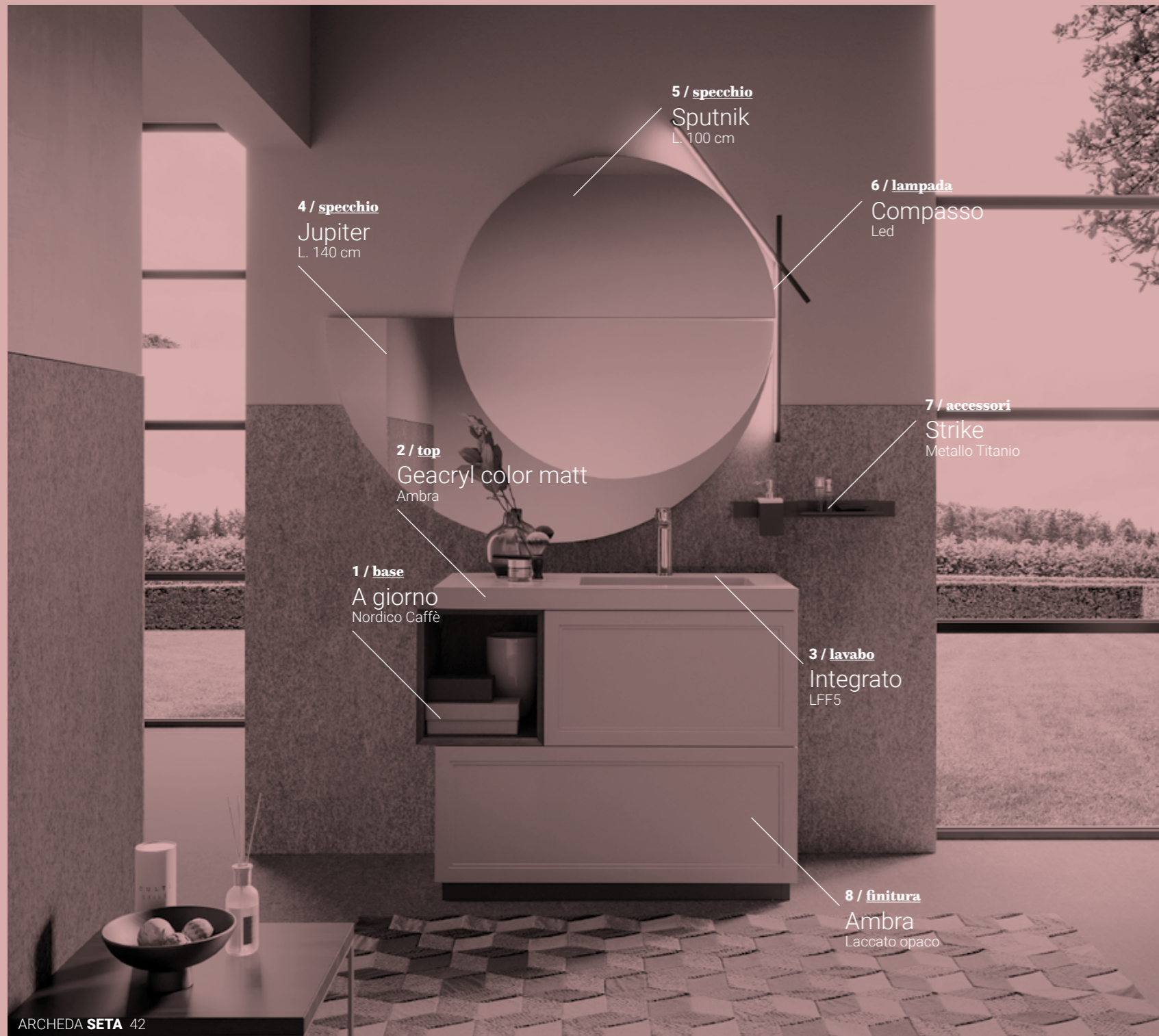

**4 / specchio**  
Jupiter  
L. 140 cm

**1 / base**  
A giorno  
Nordico Caffè

**2 / top**  
Geacryl color matt  
Ambra

**5 / specchio**  
Sputnik  
L. 100 cm

**3 / lavabo**  
Integrato  
LFF5

**8 / finitura**  
Ambra  
Laccato opaco

**6 / lampada**  
Compasso  
Led

**7 / accessori**  
Strike  
Metallo Titanio

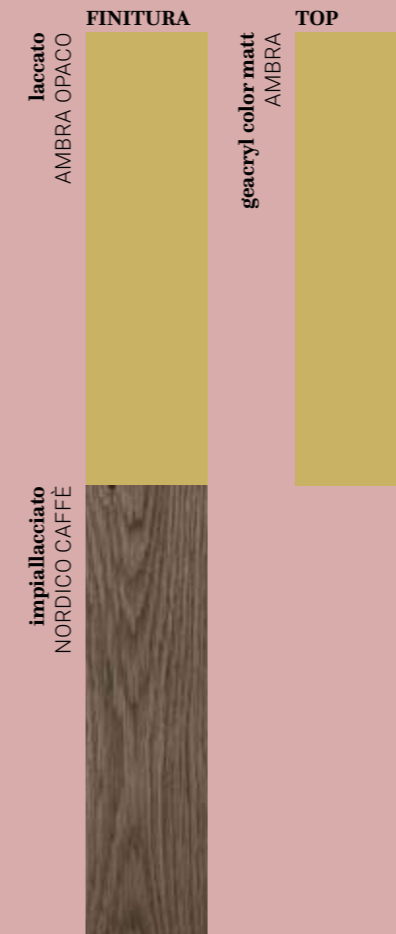
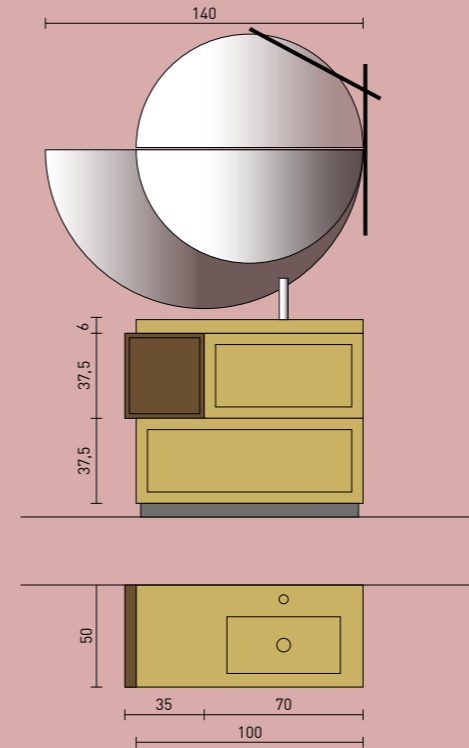

**\_ 1**  
**Base a giorno con bordi 45° in Nordico Caffè**  
**EN** Nordico Caffè with 45° edges open base units  
**FR** Element bas ouvert avec bords à 45° Nordico Caffè  
**DE** Offener Unterschrank mit 45° Kanten aus Nordico Caffè  
**ES** Mueble bajo abierto con bordes de 45° de Nordico Caffè

**\_ 2**  
**Top Geacryl color Matt Ambra sp. 6 cm**  
**EN** Th.6 cm Geacryl color Matt Ambra top  
**FR** P.d.T. en Geacryl color Matt Ambra ep.6 cm  
**DE** Waschtischplatte aus Geacryl color Matt Ambra st.6 cm  
**ES** Encimera de Geacryl color Matt Ambra esp.6 cm

**\_ 3**  
**Vasca integrata LFF5**  
**EN** LFF5 integrated washbasin  
**FR** Vasque intégrée LFF5  
**DE** Integrierte Waschbecken LFF5  
**ES** Cuba integrada LFF5

**\_ 4**  
**Specchio Jupiter con laterale fumè grigio**  
**EN** Jupiter mirror with smoked grey side segment  
**FR** Miroir Jupiter avec cadre fumé gris  
**DE** Jupiter Spiegel mit grau geräucherter Seite  
**ES** Espejo Jupiter con lado ahumado gris

**\_ 5**  
**Specchio Sputnik L. 100 H.50 cm**  
**EN** Sputnik mirror W. 100 H. 50 cm  
**FR** Miroir Sputnik L. 100 H. 50 cm  
**DE** Sputnik Spiegel B.100 H.50 cm  
**ES** Espejo Sputnik 100 x 50 cm

**\_ 6**  
**Lampada a led Compasso in metallo nero**  
**EN** Black metal Compasso led lamp  
**FR** Lampe Compasso en metal noir  
**DE** Led-Lampe Compasso aus schwarzem Metall  
**ES** Lámpara led Compasso de metal negro

**\_ 7**  
**Accessori Strike in metallo Titanio**  
**EN** Titanio metal Strike accessories  
**FR** Accessories Strike en métal Titanio  
**DE** Accessoires Strike aus Titanio Metall  
**ES** Accesorios Strike de metal Titanio

**\_ 8**  
**Basi laccate Ambra opaco**  
**EN** Ambra matt lacquered base units  
**FR** Éléments bas lacqués Ambra mat  
**DE** Matt Ambra lackierte Unterschranke  
**ES** Muebles bajos lacados Ambra mate





Un **designer** è  
una sintesi di artista,  
inventore, meccanico,  
economista e stratega.  
(Buckminster Fuller)

MODELLO **SETA**  
COMP. **S05**









**1 / accessori**  
Tratto  
Metallo Titanio

**2 / top**  
Geacryl color matt  
Juta

**3 / lavabo**  
Nicole Ovale  
Canapa

**6 / specchio**  
Virgola  
Metallo Titanio

**7 / lampada**  
Rossini  
Led

**8 / accessori**  
Strike  
Metallo Titanio

**4 / finitura**  
Juta  
Laccato opaco

**5 / base**  
A giorno  
Noce Canaletto

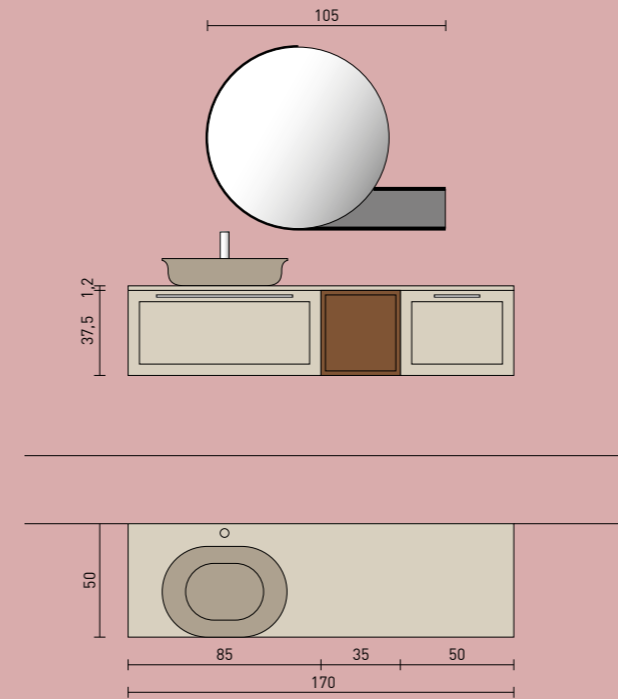

**- 1**  
**Accessori Tratto in metallo Titanio**

**EN** Titanio metal Tratto accessories  
**FR** Accessoires Tratto en métal Titanio  
**DE** Accessoires Tratto aus Titanio Metall  
**ES** Accesorios Tratto de metal Titanio

**- 5**  
**Base a giorno in Noce Canaletto**

**EN** Noce Canaletto open base units  
**FR** Element bas ouvert Noce Canaletto  
**DE** Offener Unterschrank aus Noce Canaletto  
**ES** Mueble bajo abierto de Noce Canaletto

**- 2**  
**Top Geacryl color Matt Juta sp. 1,2 cm**

**EN** Th.1,2 cm Geacryl color Matt Juta top  
**FR** P.d.T. en Geacryl color Matt Juta ep.1,2 cm  
**DE** Waschtischplatte aus Geacryl color Matt Juta st.1,2 cm  
**ES** Encimera de Geacryl color Matt Juta esp.1,2 cm

**- 6**  
**Specchio Virgola in metallo Titanio**

**EN** Titanio metal Virgola mirror  
**FR** Miroir Virgola en métal Titanio  
**DE** Virgola Spiegel aus Titanio Metall  
**ES** Espejo Virgola de metal Titanio

**- 3**  
**Lavabo Nicole Ovale Canapa**

**EN** Canapa Nicole Ovale washbasin  
**FR** Vasque Nicole Ovale Canapa  
**DE** Waschbecken Nicole Ovale Canapa  
**ES** Lavabo Nicole Ovale Canapa

**- 7**  
**Lampade Rossini con attacco a specchio**

**EN** Rossini lamps with mirror connection  
**FR** Lampes Rossini avec montage au miroir  
**DE** Rossini Lampen mit Spiegelaufsatz  
**ES** Lámparas Rossini con fijación al espejo

**- 4**  
**Basi laccate Juta Opaco**

**EN** Juta matt lacquered base units  
**FR** Éléments bas lacqués Juta mat  
**DE** Matt Juta lackierte Unterschranke  
**ES** Muebles bajos lacados Juta mate

**- 8**  
**Accessori Strike in metallo Titanio**

**EN** Titanio metal Strike accessories  
**FR** Accessoires Strike en métal Titanio  
**DE** Accessoires Strike aus Titanio Metall  
**ES** Accesorios Strike de metal Titanio



I dettagli non sono  
i dettagli.  
Fanno il **design.**  
(Charles Eames)

MODELLO **SETA**  
COMP. **S06**







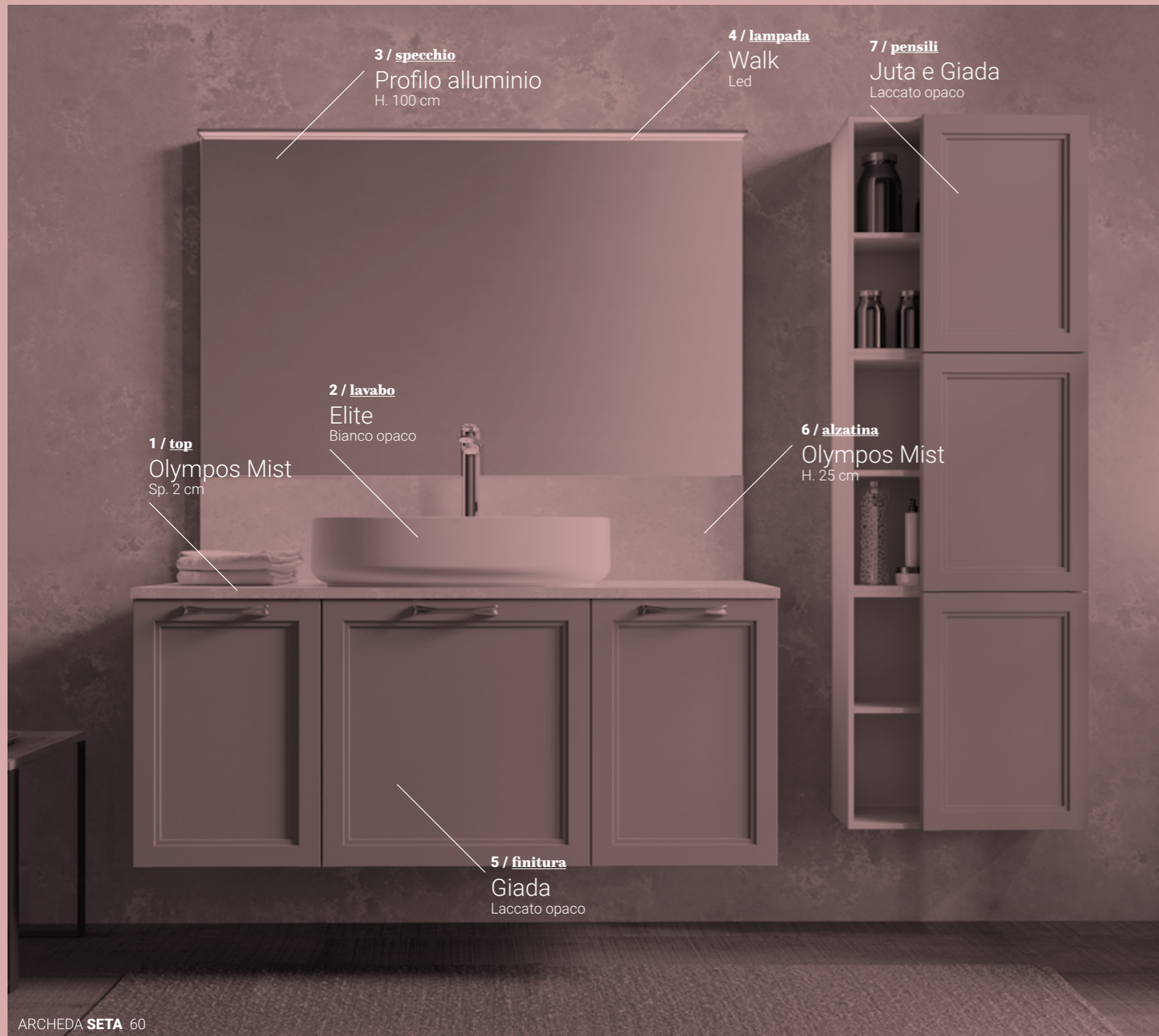

**3 / specchio**  
Profilo alluminio  
H. 100 cm

**4 / lampada**  
Walk  
Led

**7 / pensili**  
Juta e Giada  
Laccato opaco

**2 / lavabo**  
Elite  
Bianco opaco

**6 / alzatina**  
Olympos Mist  
H. 25 cm

**1 / top**  
Olympos Mist  
Sp. 2 cm

**5 / finitura**  
Giada  
Laccato opaco

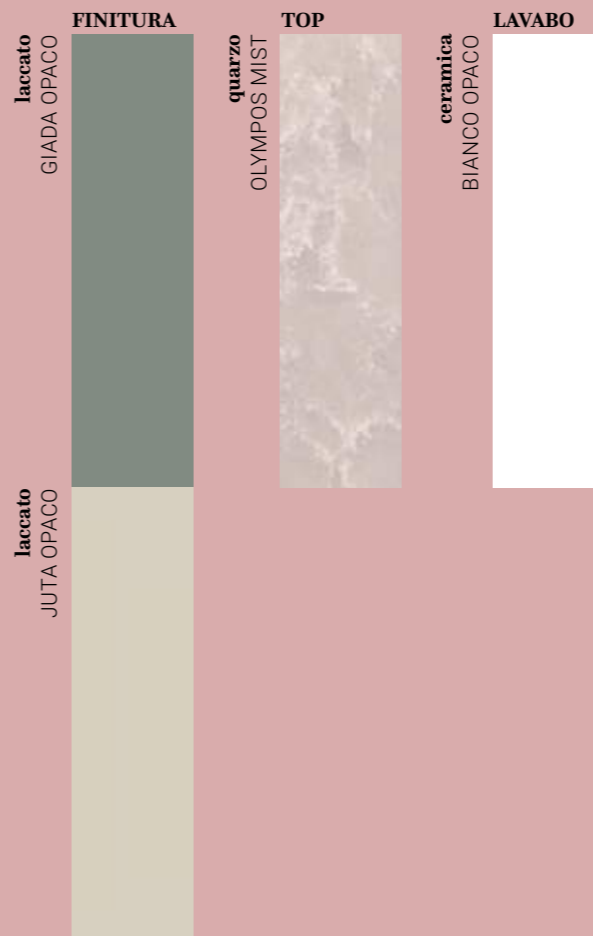
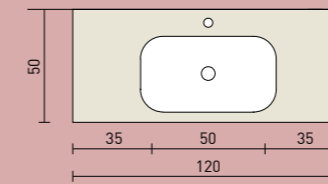
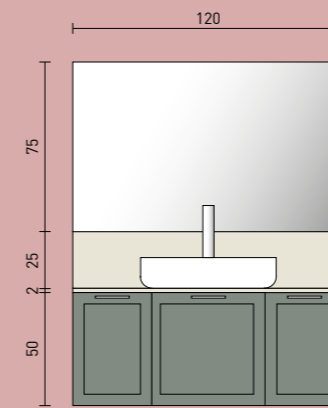

**\_ 1**  
**Top Olympos Mist**  
**sp. 2 cm**  
**EN** Th.2 cm Olympos Mist top  
**FR** Pd.T. en Olympos Mist ep.2 cm  
**DE** Waschtischplatte aus Olympos Mist st.2 cm  
**ES** Encimera de Olympos Mist esp.2 cm

**\_ 2**  
**Lavabo Elite in ceramica bianca opaca**  
**EN** Elite washbasin in matt white ceramic  
**FR** Lavabo Elite en céramique blanc mat  
**DE** Waschbecken Elite aus mattweißer Keramik  
**ES** Lavabo Elite en cerámica blanca mate

**\_ 3**  
**Specchio con profili alluminio**  
**EN** Mirror with aluminum profiles  
**FR** Miroir avec profilés en aluminium  
**DE** Spiegel mit Aluminiumprofilen  
**ES** Espejo con perfiles de aluminio

**\_ 4**  
**Lampada Walk a led**  
**EN** Walk Led lamp  
**FR** Lampe à Led Walk  
**DE** Led-Lampe Walk  
**ES** Lámpara led Walk

**\_ 5**  
**Basi laccate Giada opaco**  
**EN** Giada matt lacquered base units  
**FR** Éléments bas lacqués Giada mat  
**DE** Matt Giada lackierte Unterschranke  
**ES** Muebles bajos lacados Giada mate

**\_ 6**  
**Alzatina Olympos Mist**  
**H. 25 cm**  
**EN** H.25 cm Olympos Mist upstand  
**FR** Dossieret H.25 cm en Olympos Mist  
**DE** H.25 cm Olympos Mist Aufkantung  
**ES** Copete de Olympos Mist alt.25 cm

**\_ 7**  
**Pensili a giorno Juta opaco con ante Giada opaco**  
**EN** Matt Juta open wall units with matt Giada doors  
**FR** Éléments hauts ouverts Matt Juta avec portes Giada mates  
**DE** Offene Oberschränke Juta Matt mit Türen Giada Matt  
**ES** Muebles altos abiertos Juta mate con puertas Giada mate



Il **design** è una  
soluzione a un problema.  
L'arte è una domanda a  
un problema.

(John Maeda)

MODELLO **SETA**  
COMP. **S07**





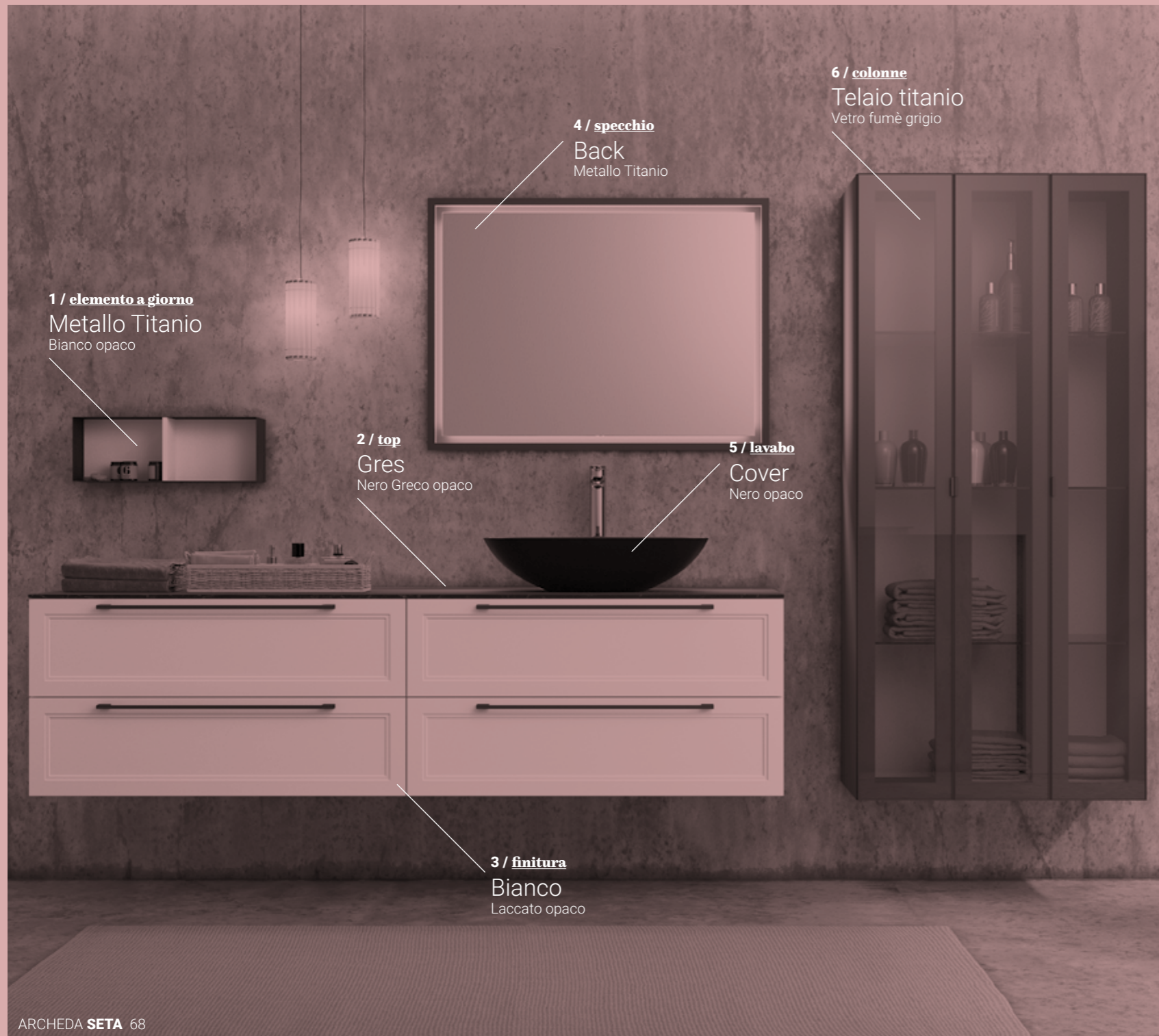

**1 / elemento a giorno**  
Metallo Titanio  
Bianco opaco

**2 / top**  
Gres  
Nero Greco opaco

**3 / finitura**  
Bianco  
Laccato opaco

**4 / specchio**  
Back  
Metallo Titanio

**5 / lavabo**  
Cover  
Nero opaco

**6 / colonne**  
Telaio titanio  
Vetro fumè grigio

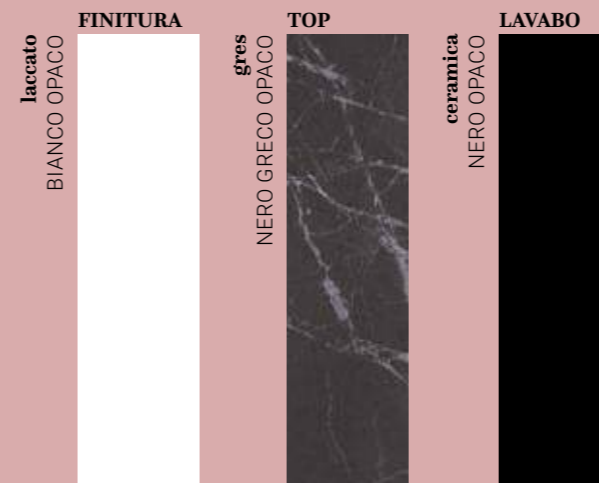
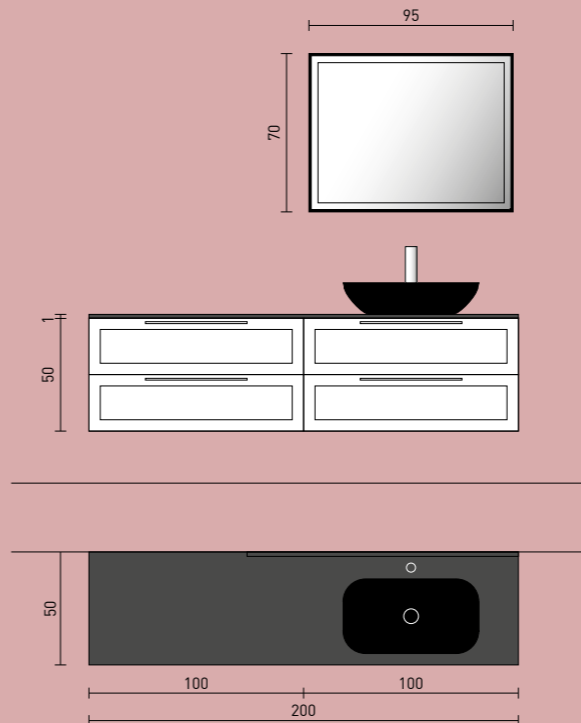

**\_ 1**  
**Elemento a giorno in metallo Titanio con retro Bianco opaco**  
**EN** Open element in Titanio metal with matt Bianco back  
**FR** Élément ouvert en métal Titanio avec dos Bianco mat  
**DE** Offenes Element aus Metall Titanio mit matt Bianco Rückseite  
**ES** Elemento abierto de metal titanio con fondo Bianco mate

**\_ 2**  
**Top gres Nero Greco opaco**  
**EN** Nero Greco matt gres top  
**FR** P.d.T. en gres Nero Greco mat  
**DE** Waschtischplatte aus Gres Nero Greco matt  
**ES** Encimera de Gres Nero Greco Mate

**\_ 3**  
**Basi laccate Bianco opaco**  
**EN** Bianco matt lacquered base units  
**FR** Éléments bas lacqués Bianco mat  
**DE** Matt Bianco lackierte Unterschränke  
**ES** Muebles bajos lacados Bianco mate

**\_ 4**  
**Specchio Back in metallo Titanio con illuminazione a Led**  
**EN** Back mirror in Titanio metal with LED lighting  
**FR** Miroir Back en métal Titanio avec éclairage LED  
**DE** Spiegel Back aus Titanio metall mit LED-Beleuchtung  
**ES** Espejo Back en metal titanio con iluminación LED

**\_ 5**  
**Lavabo Cover in ceramica nera opaca**  
**EN** Cover washbasin in matt black ceramic  
**FR** Lavabo Cover en céramique noir mat  
**DE** Waschbecken Cover aus mattschwarze Keramik  
**ES** Lavabo Cover en cerámica negra mate

**\_ 6**  
**Colonne con ante telaio alluminio tinto Titanio e vetro fumè grigio**  
**EN** Tall units with Titanio aluminum frame doors and gray smoked glass  
**FR** Colonnes avec portes à cadre en aluminium teinté Titanio et verre fumé gris  
**DE** Hochschränke mit Titanio Aluminiumrahmentüren und grauem Rauchglas  
**ES** Columnas con marco de puertas de aluminio teñido Titanio y vidrio ahumado gris



Un **designer** dovrebbe sapere che gli oggetti possono diventare lo strumento di un rito esistenziale.

(Ettore Sottsass)

MODELLO **SETA**  
COMP. **S08**







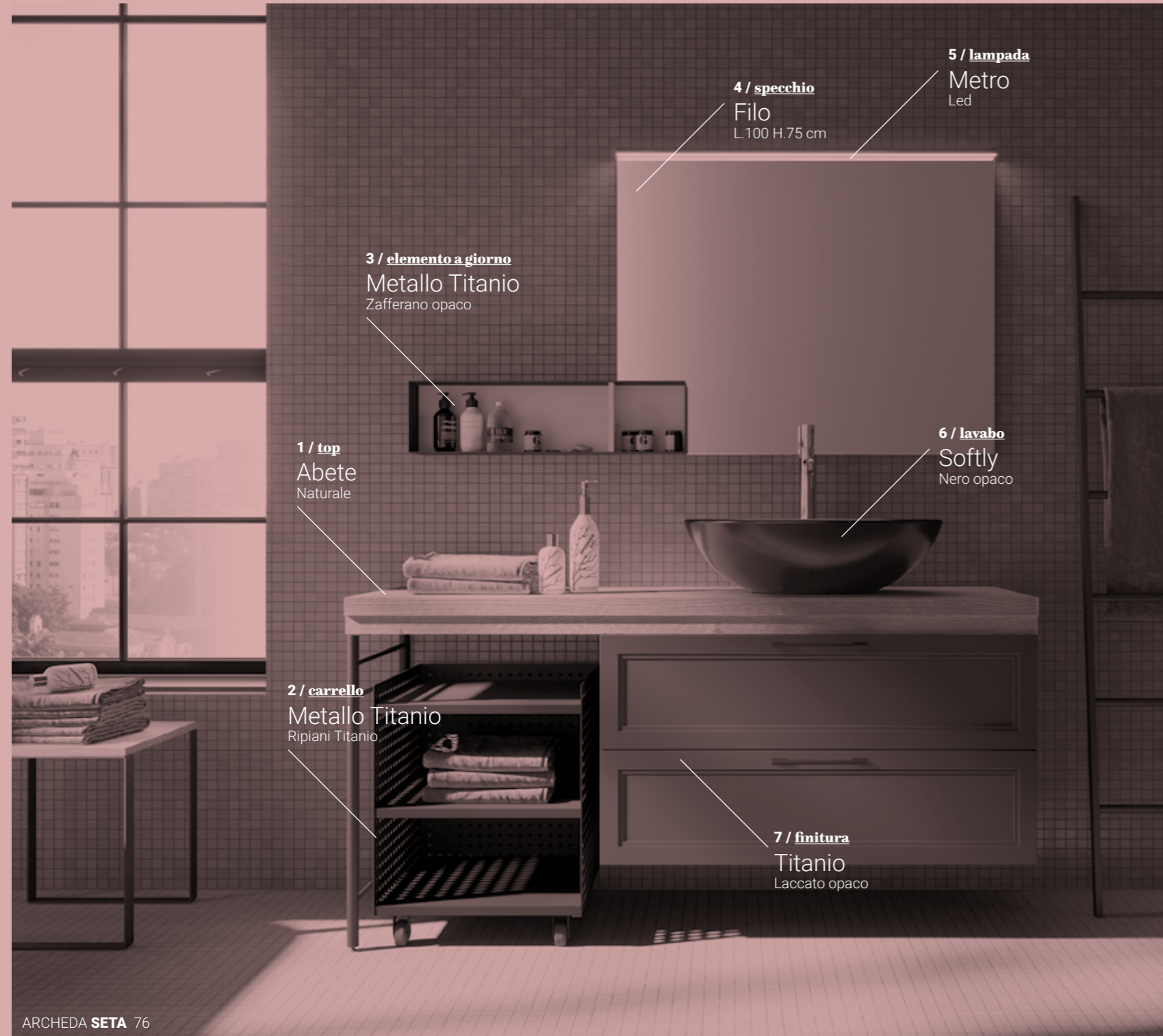

- 1 / top  
Abete Naturale
- 2 / carrello  
Metallo Titanio  
Ripiani Titanio
- 3 / elemento a giorno  
Metallo Titanio  
Zafferano opaco
- 4 / specchio  
Filo  
L.100 H.75 cm
- 5 / lampada  
Metro  
Led
- 6 / lavabo  
Softly  
Nero opaco
- 7 / finitura  
Titanio  
Laccato opaco

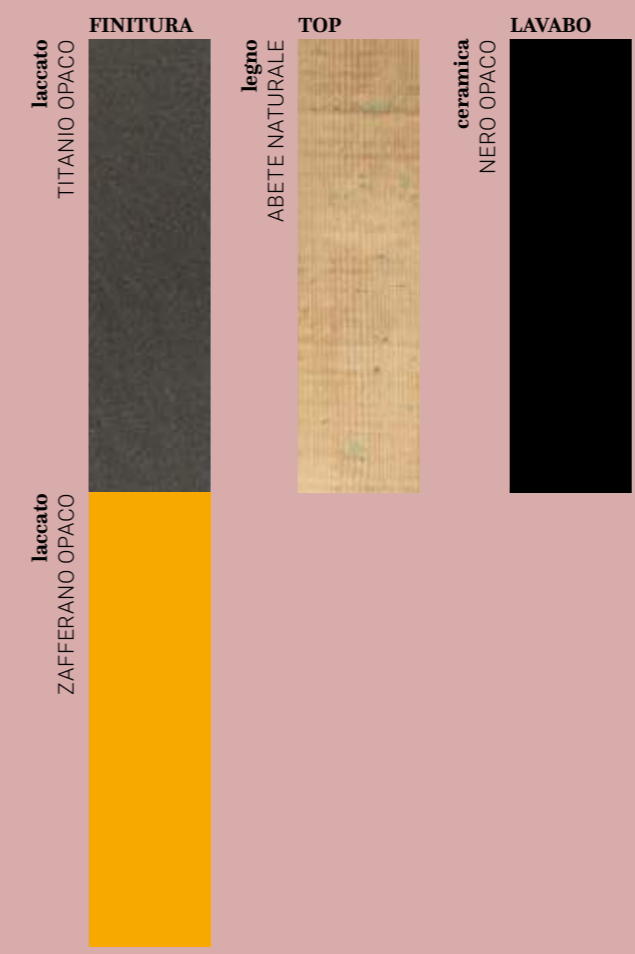
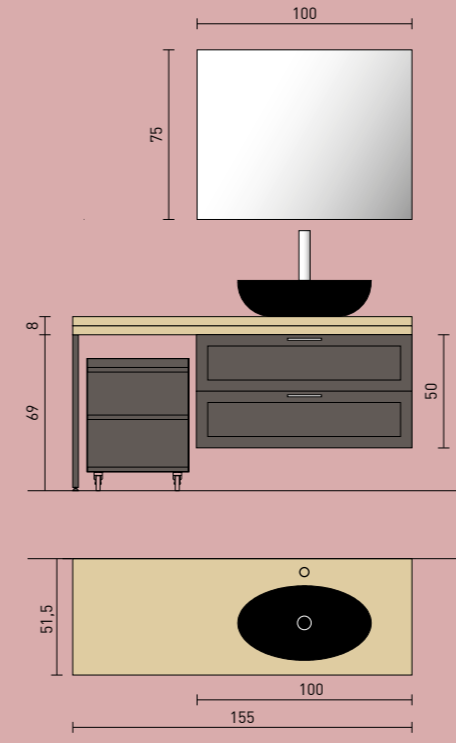

**- 1**  
**Top Abete Naturale sp.8 cm con bordo rientrante**  
EN Th.8 cm Abete Naturale top with recessed front edge top  
FR P.d.T. ep.8 cm en Abete Naturale avec chant rentrant  
DE Waschtischplatte aus Abete Naturale st.8 cm mit abgesetztem Rand  
ES Encimera de Abete Naturale sp.8 cm con borde rebajado

**- 4**  
**Specchio Filo**  
EN Filo mirror  
FR Miroir Filo  
DE Filo Spiegel  
ES Espejo Filo

**- 5**  
**Lampada Metro a led**  
EN Metro led lamp  
FR Lampe à Led Metro  
DE Led-Lampe Metro  
ES Lámpara led Metro

**- 2**  
**Carrello in metallo forato Titanio con ripiani laccati Titanio**  
EN Trolley in Titanio pierced metal with Titanio lacquered shelves  
FR Chariot en métal percé Titanio avec étagères laquées Titanio  
DE Servierwagen aus durchbrochenem Titanio Metall mit Regalen in Titanio-Lackierung  
ES Carro de metal calado Titanio con estantes lacados Titanio

**- 6**  
**Lavabo Softly in ceramica nera opaca**  
EN Softly washbasin in matt black ceramic  
FR Lavabo Softly en céramique noir mat  
DE Waschbecken Softly aus mattschwarze Keramik  
ES Lavabo Softly en cerámica negra mate

**- 3**  
**Elemento a giorno in metallo Titanio con retro Zafferano opaco**  
EN Open element in Titanio metal with matt Zafferano back  
FR Élément ouvert en métal Titanio avec dos Zafferano mat  
DE Offenes Element aus Metall Titanio mit matt Zafferano Rückseite  
ES Elemento abierto de metal titanio con fondo Zafferano mate

**- 7**  
**Base laccata Titanio opaco**  
EN Titanio matt lacquered base unit  
FR Élément bas lacqué Titanio mat  
DE Matt Titanio lackiert Unterschrank  
ES Muebles bajos lacados Titanio mate



Le persone non usano un prodotto a causa dell'ottimo **design**; un ottimo design li aiuta a usare il prodotto.

(Viran Anuradha Dayaratne)

MODELLO **SETA**  
COMP. **S09**





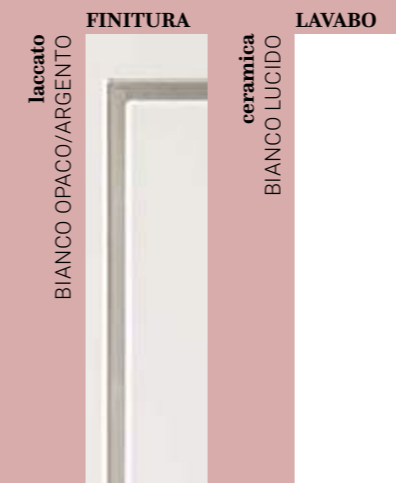
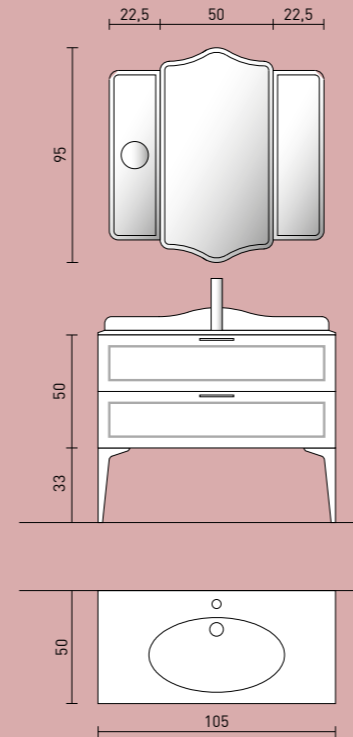
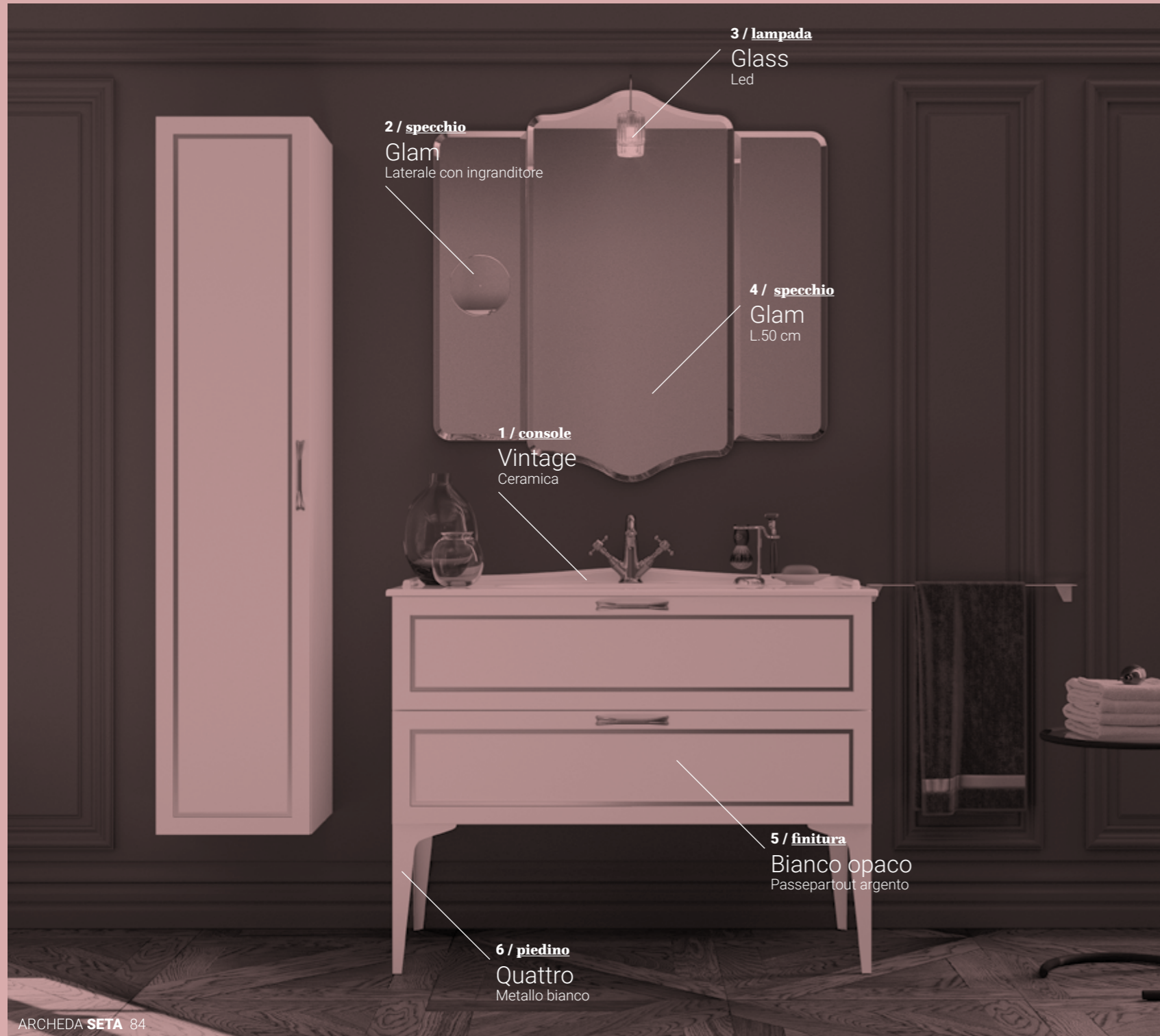

**\_ 1**  
**Console Vintage in  
ceramica bianca**

**EN** Vintage console in  
white ceramic  
**FR** Console Vintage en  
céramique blanc  
**DE** Console Vintage aus  
weißer Keramik  
**ES** Console Vintage de  
cerámica blanca

**\_ 2**  
**Specchio laterale Glam  
con ingranditore**

**EN** Glam side mirror with  
magnifier  
**FR** Miroir latéral avec  
grossissant Glam  
**DE** Seitenspiegel Glam mit  
Vergrößerer  
**ES** Espejo lateral con  
amplificadora Glam

**\_ 3**  
**Lampada Glass a led**

**EN** Glass led lamp  
**FR** Lampe à Led Glass  
**DE** Led-Lampe Glass  
**ES** Lámpara led Glass

**\_ 4**  
**Specchio Glam**

**EN** Glam mirror  
**FR** Miroir Glam  
**DE** Glam Spiegel  
**ES** Espejo Glam

**\_ 5**  
**Base Bianco opaco -  
Passepartout Argentio**

**EN** Bianco matt -  
Passepartout Argentio  
lacquered base units  
**FR** Élément bas lacqué  
Bianco mat - Passepartout  
Argentio  
**DE** Matt Bianco -  
Passepartout Argentio  
lackiert Unterschrank  
**ES** Mueble bajo  
lacado Bianco mate -  
Passepartout Argentio

**\_ 6**  
**Piedino Quattro in  
metallo Bianco**

**EN** Quattro white metal  
foot  
**FR** Pied Quattro en métal  
blanc  
**DE** Quattro Fuß aus  
weißem Metall  
**ES** Pie Quattro de metal  
blanco



Un **design** ben pensato non solo farà avere successo al marketing del prodotto, ma anche al prodotto stesso.

(Jeffrey Zeldman)

MODELLO **SETA**  
COMP. **S10**







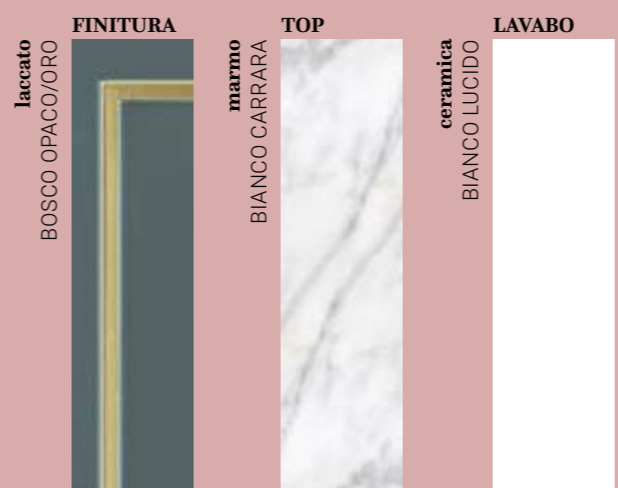
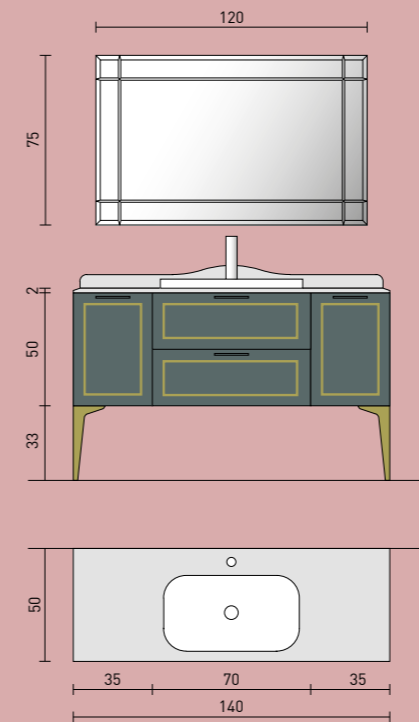
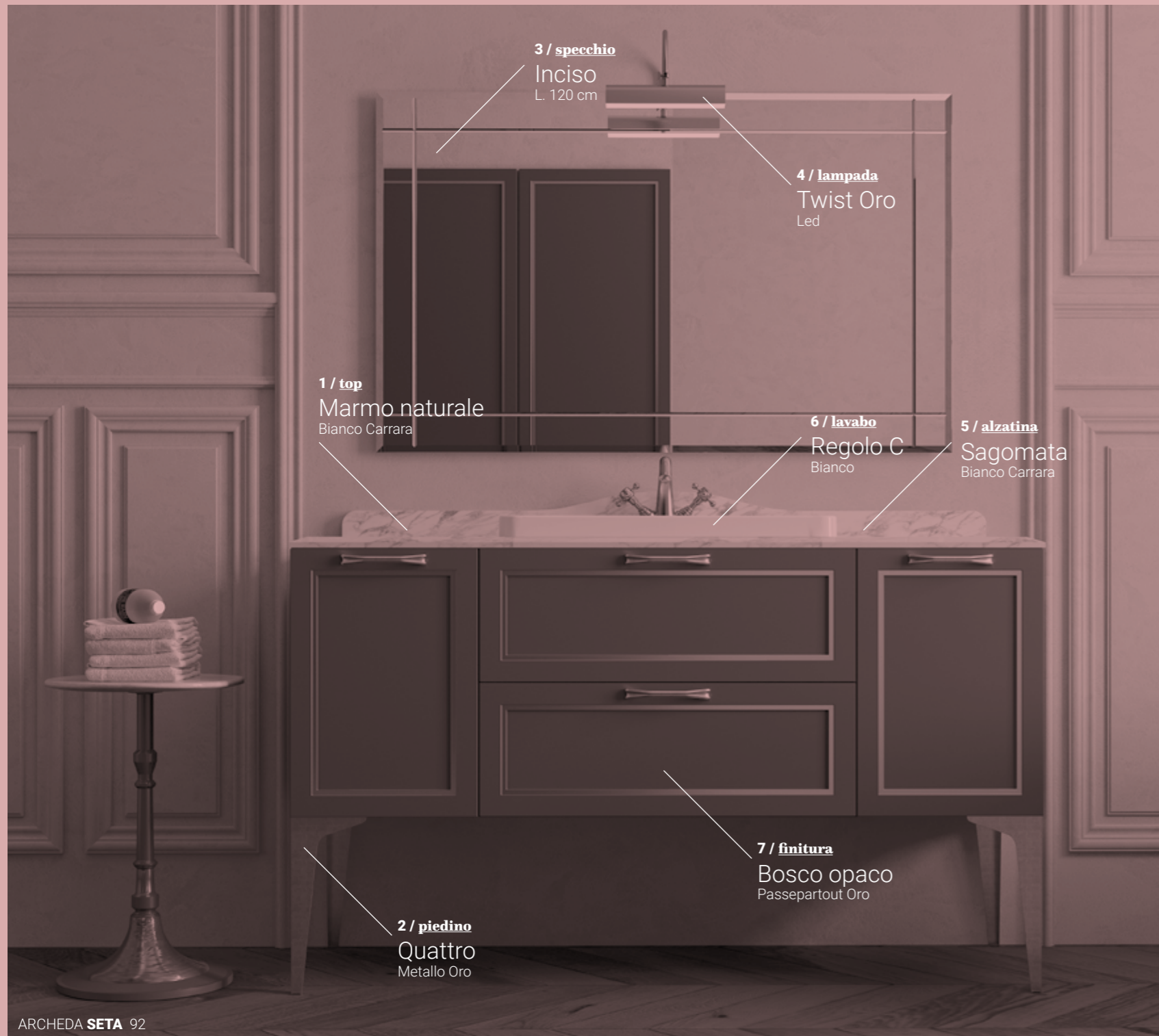

**\_ 1**  
**Top in marmo Bianco Carrara sp. 2 cm**  
EN Th.2 cm Bianco Carrara top  
FR Pd.T. en Bianco Carrara ep.2 cm  
DE Waschtischplatte aus Bianco Carrara st.2 cm  
ES Encimera de Bianco Carrara esp.2 cm

**\_ 5**  
**Alzatina sagomata in marmo Bianco Carrara**  
EN Bianco Carrara shaped upstand  
FR Dossieret galbé en Bianco Carrara  
DE Bianco Carrara geformte Aufkantung  
ES Copete con forma de Bianco Carrara

**\_ 2**  
**Piedino Quattro in metallo Oro**  
EN Quattro Oro metal foot  
FR Pied Quattro en métal Oro  
DE Quattro Fuß aus Oro Metall  
ES Pie Quattro de metal Oro

**\_ 6**  
**Lavabo Regolo C in ceramica bianca**  
EN Regolo C washbasin in white ceramic  
FR Lavabo Regolo C en céramique blanc  
DE Waschbecken Regolo C aus weißer Keramik  
ES Lavabo Regolo C en cerámica blanca

**\_ 3**  
**Specchio Inciso**  
EN Inciso mirror  
FR Miroir Inciso  
DE Spiegel Inciso  
ES Espejo Inciso

**\_ 7**  
**Basi Bosco opaco - Passepartout Oro**  
EN Bosco matt - Passepartout Oro lacquered base units  
FR Éléments bas lacquée Bosco mat - Passepartout Oro  
DE Matt Bosco - Passepartout Oro lackierte Unterschränke  
ES Muebles bajos lacados Bosco mate - Passepartout Oro

**\_ 4**  
**Lampada Twist Oro a led**  
EN Twist Oro led lamp  
FR Lampe à Led Twist Oro  
DE Led-Lampe Twist Oro  
ES Lámpara led Twist Oro



Gli stili vanno e vengono.  
Il buon **design** è un  
linguaggio, non uno stile.  
(Massimo Vignelli)

MODELLO **SETA**  
COMP. **S11**





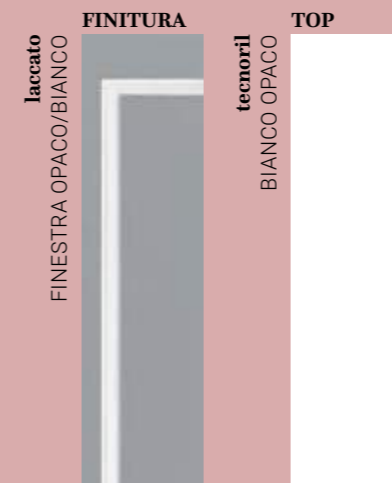
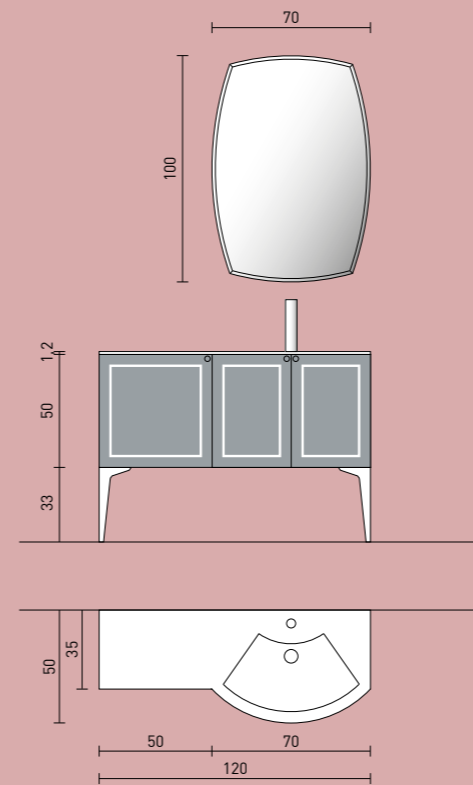

**\_ 1**  
**Top Tecnoril sp. 1,2 cm**  
**EN** Th.1,2 cm Tecnoril top  
**FR** Pd.T. en Tecnoril ep.1,2 cm  
**DE** Waschtischplatte aus Tecnoril st.1,2 cm  
**ES** Encimera de Tecnoril esp.1,2 cm

**\_ 2**  
**Piedino Quattro in metallo Bianco**  
**EN** Quattro white metal foot  
**FR** Pied Quattro en métal blanc  
**DE** Quattro Fuß aus weißem Metall  
**ES** Pie Quattro de metal blanco

**\_ 3**  
**Mensola in metallo Bianco**  
**EN** White metal shelf  
**FR** Étagère en métal Blanc  
**DE** Regal aus weißem Metall  
**ES** Estante de metal blanco

**\_ 4**  
**Lampada Sfera a Led**  
**EN** Sfera led lamp  
**FR** Lampe à Led Sfera  
**DE** Led-Lampe Sfera  
**ES** Lámpara led Sfera

**\_ 5**  
**Specchio Vintage L. 70 cm**  
**EN** W. 70 cm Vintage mirror  
**FR** Miroir Vintage L. 70 cm  
**DE** Vintage Spiegel B. 70 cm  
**ES** Espejo Vintage ancho 70 cm

**\_ 6**  
**Vasca integrata ACC5**  
**EN** ACC5 integrated washbasin  
**FR** Vasque intégrée ACC5  
**DE** Integrierte Waschbecken ACC5  
**ES** Cuba integrada ACC5

**\_ 7**  
**Basi Finestra opaco - Passepartout Bianco**  
**EN** Finestra matt - Passepartout Bianco lacquered base units  
**FR** Eléments bas lacquée Finestra mat - Passepartout Bianco  
**DE** Matt Finestra - Passepartout Bianco lackierte Unterschränke  
**ES** Muebles bajos lacados Finestra mate - Passepartout Bianco



Il **design** non è come sembra o come appare. Il **design** è come funziona.

(Steve Jobs)

MODELLO **SETA**  
COMP. **S12**







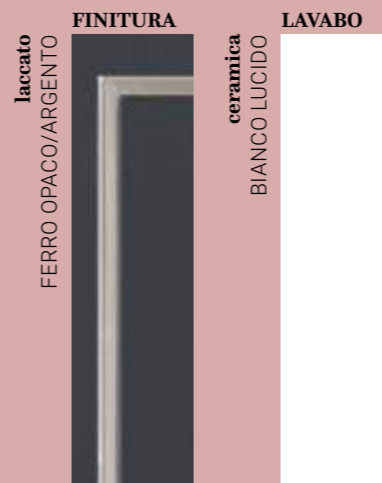
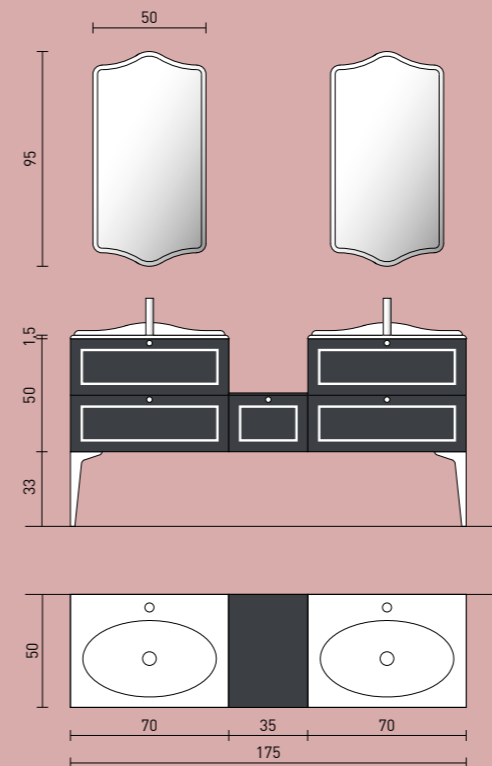

**\_ 1**  
**Accessori Tratto in metallo Bianco**

**EN** White metal Tratto accessories  
**FR** Accessoires Tratto en métal blanc  
**DE** Accessoires Tratto aus weißem Metall  
**ES** Accesorios Tratto de metal blanco

**\_ 5**  
**Piedino Quattro in metallo Bianco**

**EN** Quattro white metal foot  
**FR** Pied Quattro en métal blanc  
**DE** Quattro Fuß aus weißem Metall  
**ES** Pie Quattro de metal blanco

**\_ 2**  
**Console Vintage in ceramica bianca**

**EN** Vintage console in white ceramic  
**FR** Console Vintage en céramique blanc  
**DE** Console Vintage aus weißer Keramik  
**ES** Console Vintage en cerámica blanca

**\_ 6**  
**Basi Ferro opaco - Passepartout Argentio**

**EN** Ferro matt - Passepartout Argentio lacquered base units  
**FR** Éléments bas lacquée Ferro mat - Passepartout Argentio  
**DE** Matt Ferro - Passepartout Argentio lackierte Unterschränke  
**ES** Muebles bajos lacados Ferro mate - Passepartout Argentio

**\_ 3**  
**Specchio Glam L. 50 cm**

**EN** W. 50 cm Glam mirror  
**FR** Miroir Glam L. 50 cm  
**DE** Glam Spiegel B. 50 cm  
**ES** Espejo Glam ancho 50 cm

**\_ 4**  
**Lampada Glass a led**

**EN** Glass led lamp  
**FR** Lampe à Led Glass  
**DE** Led-Lampe Glass  
**ES** Lámpara led Glass



MODELLO **SETA**  
ACCESSORI **& finiture**

## Finiture

Finishes  
Finitions  
Ausführungen  
Acabados

### Laccato opaco

Matt lacquered / Lacquée mat  
Matt lackiert / Lacado mate



## Finiture

Finishes  
Finitions  
Ausführungen  
Acabados

### Laccato lucido

Gloss lacquered / Lacqué brillant  
Glänzend lackiert / Lacado Brillo



BIANCO 01

### Passepartout (solo finitura opaca)

Only matt / Seulement mat  
Nur matt / Solamente mate

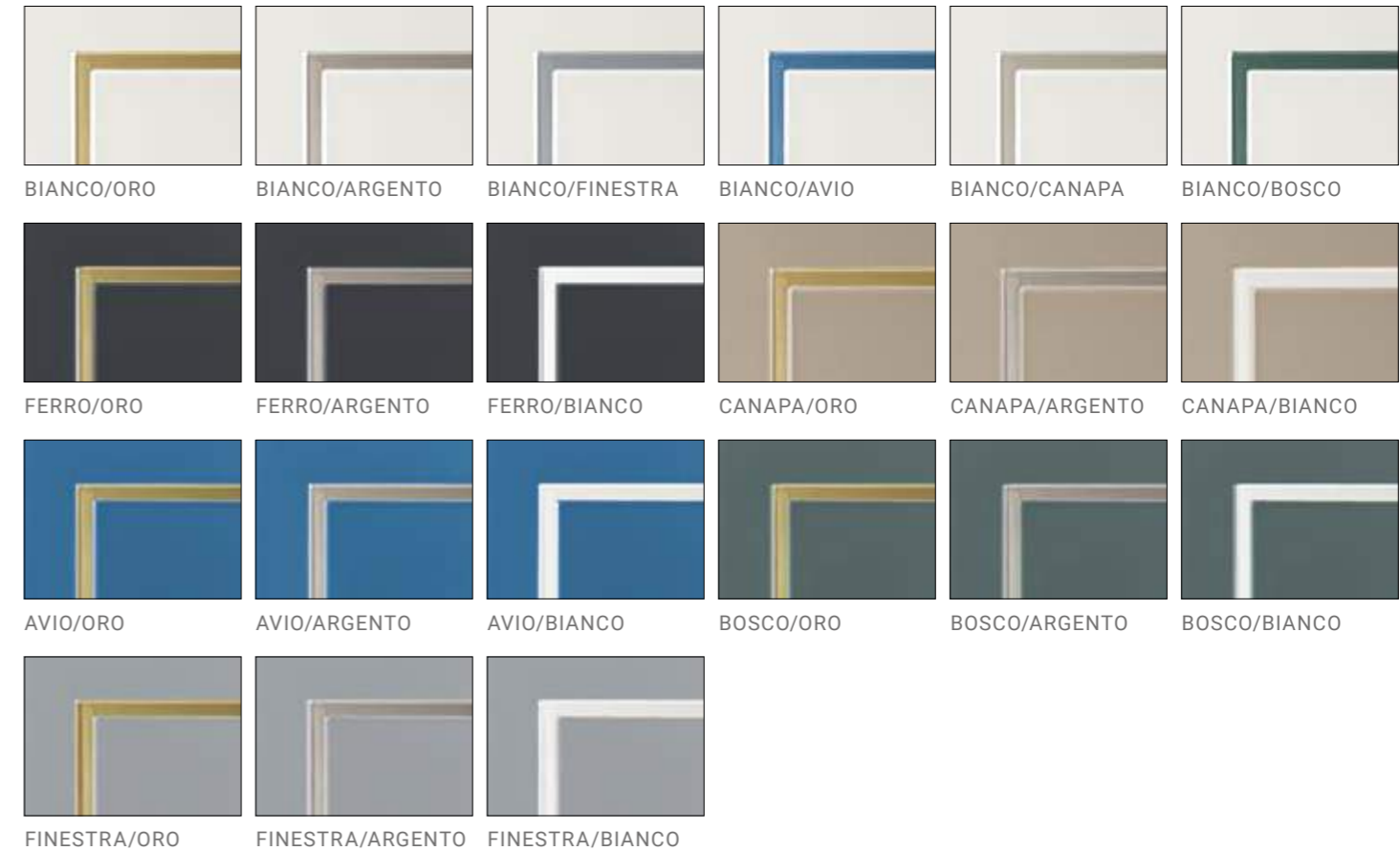

## Maniglie

Handles  
Poignées  
Griffe  
Tiradores

### Standard:



M27 ARGENTO

### Optional:



M28 ORO



M20 OSSIDATO BRILL



M25 NICHEL SPAZZOLATO



P9 NICHEL CERAMICA



M21 BIANCO



M26 TITANIO



P10 NICHEL SATINATO



M22 TITANIO

## Vasche

Bath Tubs  
Baignores  
Badewanne  
Bañeras

### Milord:

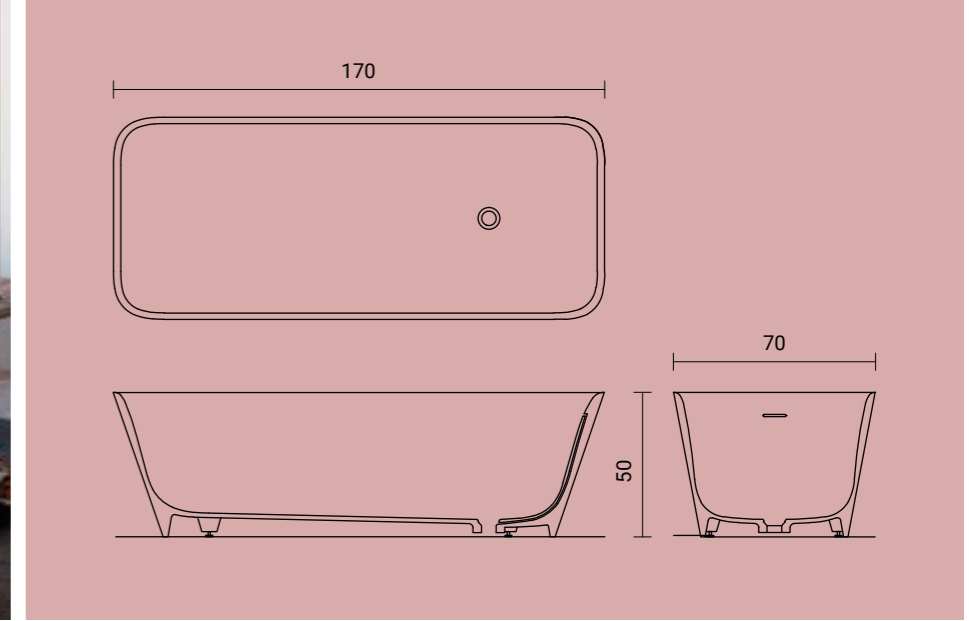

### Milady:

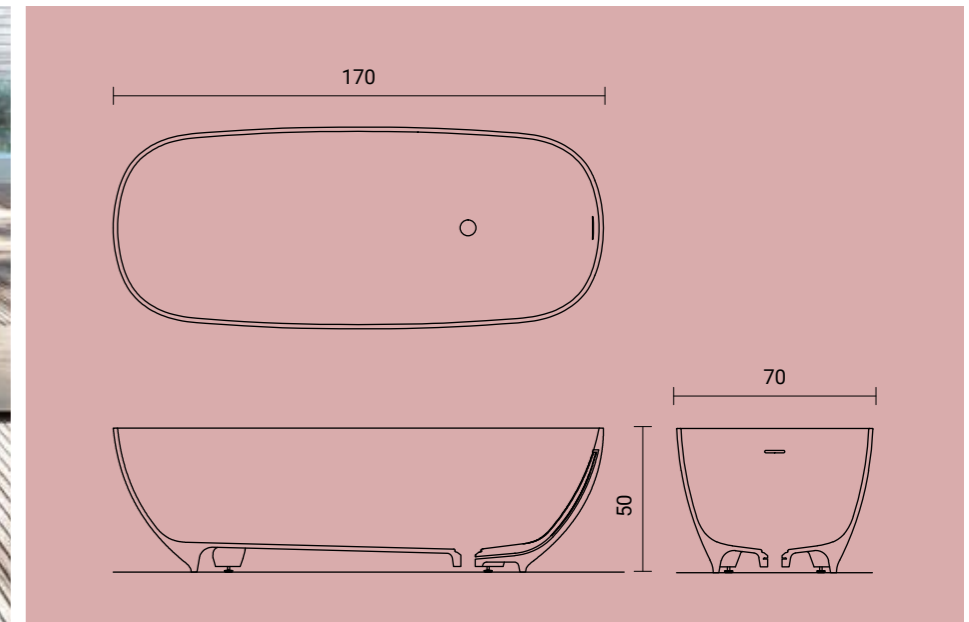

## CATALOGUE PLANNIG

Maurizio Poletto

## DESIGN E.A.D.

Dario Poles

## GRAPHIC DESIGN CATALOGO

graphosds.it

## FOTOGRAFIA

Gabriotti Fotografi

## FOTOLITO E STAMPA

graficheitalprint.it

## MARZO 2022

**Archeda, al fine di migliorare le caratteristiche tecniche e qualitative della sua produzione, si riserva di apportare, anche senza preavviso, tutte le modifiche che si rendessero necessarie.**

To improve the technical and the qualitative characteristics of the production, Archeda reserves the right to make all the suitable modifications without previous notice.

A fin daméliorer les caractéristiques techniques et qualitatives de sa production, la société Archeda se réserve le droit d'apporter, même sans preavis, toutes les modifications qui seront jugées nécessaires.

Um technische und qualitative Merkmale der Produktion zu verbessern, behält sich Archeda vor, alle nötige Abänderungen, ohne Avisierungen, vorzunehmen.

Archeda, a fin de mejorar las características técnicas y cualitativas de su producción, se reserva el derecho de aportar, incluso sin previo aviso, todas las modificaciones necesarias.



# TULLE

SISTEMA GOLA

# TULLE

SISTEMA GOLA



TULLE, UN MOBILE CON FRONTALI PIANI DAL BORDO SUPERIORE INCLINATO E CON GOLA STRUTTURALE PIATTA; AGEVOLE E FUNZIONALE SI RINNOVA NELLA GAMMA DI DECORATIVI, LEGNI, RIGATI E DOGATI SU COLORAZIONI LACCATE. SI DOTA INOLTRE DI UNA SERIE DI ACCESSORI E COMPLEMENTI: LAVABI, VASCHE, SPECCHI, MENSOLE, CONTENITORI E SISTEMI DI ILLUMINAZIONE. FORME E VOLUMI REINTERPRETATI OFFRONO NUOVE SOLUZIONI COMPOSITIVE E FUNZIONALI PER SODDISFARE OGNI ESIGENZA.

TULLE, A FURNITURE WITH SMOOTH FRONT PANELS WITH AN INCLINED UPPER EDGE AND A FLAT STRUCTURAL GROOVE; EASY AND FUNCTIONAL, IT'S RENEWD IN THE RANGE OF DECORATIVE, WOOD, RIGATO AND DOGATO ON LACQUERED COLORS. IT IS ALSO EQUIPPED WITH A SERIES OF ACCESSORIES AND COMPLEMENTS: WASHBASINS, BATHTUB, MIRRORS, SHELVES, CONTAINERS AND LIGHTING SYSTEMS. REINTERPRETED SHAPES AND VOLUMES PROVIDE NEW COMPOSITIONAL AND FUNCTIONAL SOLUTIONS TO MEET EVERY NEED.

TULLE, UN MEUBLE AVEC DES FAÇADES PLATES AVEC UN BORD SUPÉRIEUR INCLINÉ ET AVEC UNE GORGE STRUCTURELLE PLATE; FACILE ET FONCTIONNEL, SE RENOUVELLE DANS LA GAMME DE DÉCORATIONS , BOIS, RIGATO ET DOGATO SUR COULEURS LAQUÉES. IL EST ÉGALEMENT ÉQUIPÉ D'UNE SÉRIE D'ACCESSOIRES ET DE COMPLÉMENTS : VASQUES, BAINOIRES, MIROIRS, ÉTAGÈRES, ÉLÉMENTS CONTENEURS ET SYSTÈMES D'ÉCLAIRAGE. FORMES ET VOLUMES RÉINTERPRÉTÉS OFFRENT DE NOUVELLES SOLUTIONS COMPOSITIVES ET FONCTIONNELLES POUR SATISFAIRE TOUS LES BESOINS.

TULLE, EIN MÖBEL MIT GLATTEN FRONTPLATTEN MIT EINER GENEIGTEN OBERKANTE UND EINER FLACHEN STRUKTURGRIFFE; EINFACH UND FUNKTIONAL, ES IST IM BEREICH DEKORATIVE, HOLZ, RIGATO UND DOGATO AUF LACKIERTEN FARBEN ERNEUERT. ES IST AUCH MIT EINER REIHE VON ZUBEHÖR UND ERGÄNZUNGEN AUSGESTATTET: WASCHBECKEN, BADEWANNE, SPIEGEL, REGALE, BEHÄLTER UND BELEUCHTUNGSSYSTEME. NEU INTERPRETIERTE FORMEN UND VOLUMEN BIETEN NEUE KOMPOSITORISCHE UND FUNKTIONELLE LÖSUNGEN FÜR JEDEN BEDARF.

TULLE, UN MUEBLE DE FRONTALES PLANOS CON BORDE SUPERIOR INCLINADO Y RANURA ESTRUCTURAL PLANA; FÁCIL Y FUNCIONAL, SE RENOVA EN LA GAMA DE ACABADOS DECORATIVOS, MADERA, RIGATO Y DOGATO EN TODOS LOS COLORES LACADOS. TAMBIÉN ESTÁ EQUIPADO CON UNA SERIE DE ACCESORIOS Y COMPLEMENTOS: LAVABOS, BAÑERAS, ESPEJOS, ESTANTES, CONTENEDORES Y SISTEMAS DE ILUMINACIÓN. FORMAS Y VOLÚMENES REINTERPRETADOS OFRECEN NUEVAS SOLUCIONES COMPOSITIVAS Y FUNCIONALES PARA SATISFACER CADA NECESIDAD.

## index

<b>01</b>	P.4
<b>02</b>	P.12
<b>03</b>	P.22
<b>04</b>	P.32
<b>05</b>	P.40
<b>06</b>	P.48
<b>07</b>	P.56
<b>08</b>	P.64
<b>09</b>	P.72
<b>10</b>	P.80
<b>11</b>	P.86
<b>12</b>	P.94
<b>13</b>	P.102
<b>14</b>	P.110
<b>15</b>	P.120
<b>16</b>	P.128

RICERCA,  
DESIGN,  
INNOVAZIONE,  
SOSTENIBILITÀ.



# 01

## MATERIALI

Frontali in RIGATO Juta opaco, gola Titanio opaco  
 Fianchi di finitura e top in Gres Shilin Slate,  
 vasca integrata GZZ5 con scarico ispezionabile

## ACCESSORI

Specchio Raggio retroilluminato  
 Lampade a sospensione Rossini  
 Mensola Pass-by laccata Juta opaco  
 con illuminazione led  
 Portasalviette Under metallo titanio

## MATERIALS

Fronts Juta RIGATO matt, recessed handle Titanio  
 matt, end side panel and top Gres Shilin Slate,  
 integrated washbasin GZZ5 with inspectable drain

## ACCESSORIES

Mirror Raggio with perimeter lamp and Rossini  
 hanging lamps  
 Pass-by shelf lacquered Juta matt with LED light on  
 the lower part and towel rack Under in metal Titanio

## MATÉRIAUX

Façades en RIGATO Juta mat, gorge en Titanio mat  
 Côtés de finition et plan de toilette en Gres Shilin  
 Slate, vasque intégrée GZZ5 avec évacuation  
 inspectable

## ACCESSOIRES

Miroir Raggio avec éclairage périmétral et lampes  
 suspendues Rossini  
 Étagère Pass-by laquée en Juta mat  
 avec éclairage LED dans la partie inférieure  
 et porte-serviette Under en métal Titanio

## MATERIALIEN

Fronten Juta RIGATO matt, Griffmulde Titanio matt,  
 Seitenpanel und Oberseite Gres Shilin Slate,  
 integriertem Waschbecken GZZ5  
 mit inspizierbarem Ablauf

## ZUBEHÖRE

Spiegel Raggio mit Perimeterlampe  
 und Rossini Hängelampen  
 Pass-by Regal lackiert Juta matt  
 mit LED-Licht auf dem unteren Teil  
 und Handtuchhalter Under in Metall Titanio

## MATERIALES

Frontales en RIGATO Juta mate, ranura Titanio mate  
 Laterales y encimera de Gres Shilin Slate, lavabo  
 integrado GZZ5 con descarga inspeccionable

## ACCESORIOS

Espejo Raggio con iluminación perimetral  
 y lámparas colgantes Rossini  
 Estante Pass-by lacado Juta mate  
 con iluminación led en la parte inferior  
 y toallero Under en metal Titanio

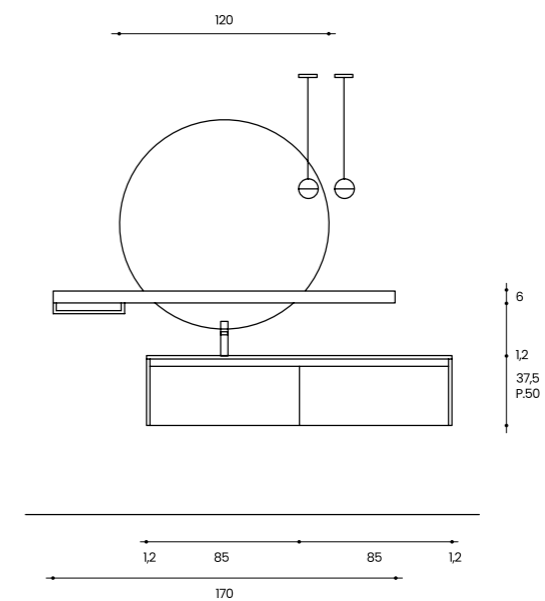





La mensola **Pass-by** con illuminazione led integrata è sagomata per sovrapporsi allo specchio **Raggio**  
The **Pass-by** shelf with integrated LED light is shaped to overlap the mirror **Raggio**  
L'étagère **Pass-by** avec éclairage led intégré, est façonnée pour se superposer au miroir **Raggio**  
Das **Pass-by**-Regal mit integriertem LED-Licht ist so geformt, dass es den Spiegel **Raggio** überlappt  
El Estante **Pass-by** con iluminación LED integrada está diseñado para adaptarse al espejo **Raggio**



Porta-salviette **Under** per mensola

P.11: Vasca integrata **GZZ5** con scarico ispezionabile

Towel holder **Under** for shelf

P.11: Integrated washbasin **GZZ5** with inspectable drain

Porte-serviettes **Under** pour étagère

P.11: Vasque intégrée **GZZ5** avec évacuation inspectable

Handtuchhalter **Under** für Regal

P.11: Integriertes Waschbecken **GZZ5** mit inspizierbarem Ablauf

Toallero **Under** para estante

P.11: Lavabo integrado **GZZ5** con descarga inspeccionable



## 02

### MATERIALI

Rovere Fiammato Tartufo  
con particolari laccati Kaki opaco  
Top e lavabo Rock-Up in Geacryl  
color matt Kaki

### ACCESSORI

Specchio Lumière  
con illuminazione integrata  
nel profilo in metallo nero

### MATERIALS

Rovere Fiammato Tartufo  
with details Kaki matt lacquered  
Top and sink Rock-Up Geacryl  
color matt Kaki

### ACCESSORIES

Mirror Lumière  
with light inside the black metal profile

### MATÉRIAUX

Rovere Fiammato Tartufo  
avec détails laqués Kaki mat  
Plan de toilette et vasque à poser Rock-Up  
en Geacryl color matt Kaki

### ACCESSOIRES

Miroir de la série Lumière  
avec éclairage à l'intérieur du profil en métal noir

### MATERIALIEN

Rovere Fiammato Tartufo  
mit Details Kaki matt lackiert  
Top und Waschbecken Rock-Up  
Geacryl color matt Kaki

### ZUBEHÖRE

Spiegel Lumière  
mit Licht im schwarzen Metallprofil

### MATERIALES

Rovere Fiammato Tartufo  
con detalles lacados en Kaki mate  
Encimera y lavabo Rock-Up  
en Geacryl color matt Kaki

### ACCESORIOS

Espejo de la serie Lumière  
con iluminación en el perfil de metal negro

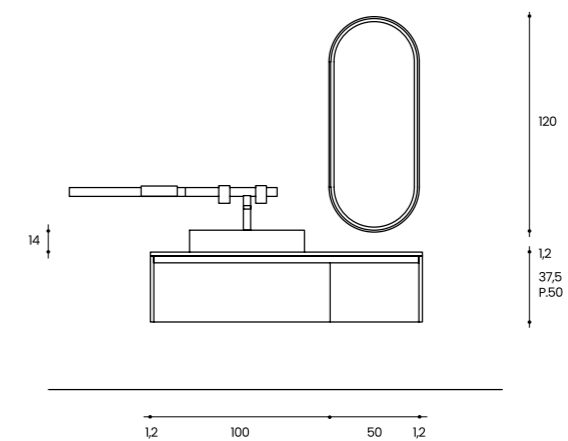





Cassetti organizzati con gli accessori **Inside**  
 in legno wengé e metallo Titanio  
 Lavabo in appoggio **Rock-up** in Geacryl color matt Kaki  
 Drawers organized with accessories **Inside**  
 in wenge wood and metal lacquered Titanio  
 Sink **Rock-up** in Geacryl color matt Kaki  
 Tiroirs organisés avec les accessoires **Inside**  
 en bois wengé et métal laqué Titanio  
 Lavabo à poser **Rock-up** en Geacryl color matt Kaki  
 Schubladen organisiert mit Zubehör **Inside**  
 in Wenge-Holz und Metall lackiert Titanio  
 Waschbecken **Rock-up** in Geacryl color matt Kaki  
 Cajones organizados con accesorios **Inside**  
 en madera de wengué y metal lacado en Titanio  
 Lavabo sobre encimera **Rock-up** en Geacryl color matt Kaki





Le colonne **Opera** possono essere completate con elementi a giorno, pannelli boiserie e specchi  
The **Opera** columns can be completed with open elements, boiserie panels, and mirrors  
Les colonnes **Opera** peuvent être complétées par des éléments ouverts, des panneaux boiserie et des miroirs  
Die **Opera**-Säulen können mit offenen Elementen, Boiserie-Paneelen und Spiegeln ergänzt werden  
Las columnas **Opera** pueden completarse con elementos abiertos, boiserie y espejos



Accessori **Strike** laccati Kaki opaco  
Accessories **Strike** in the new finish lacquered Kaki matt  
Accessoires **Strike** dans la nouvelle finition laquée Kaki mat  
Zubehör **Strike** in der neuen Lackierung Kaki matt  
Accesorios **Strike** en el nuevo acabado lacado Kaki mate





## 03

### MATERIALI

Lavabo Afrodite con colonna rigata in Okite Calacatta Oro 8052  
 Colonnine Sipario laccate Canapa opaco e copertura in Okite Calacatta Oro 8052

### ACCESSORI

Specchio Raggio con mensola Pass-by Portasalviette Under in metallo Titanio

### MATERIALS

Afrodite washbasin with striped column in Okite Calacatta Oro 8052  
 Small tall cabinet Sipario lacquered Canapa matt, lacquered inside and top Okite Calacatta Oro 8052

### ACCESSORIES

Mirror Raggio with pass-by shelf and towel rack Under in metal Titanio

### MATÉRIAUX

Vasque Afrodite avec colonne rayée en Okite Calacatta Oro 8052  
 Petites colonnes Sipario laquées en Canapa mat avec intérieur laqué et couverture en Okite Calacatta Oro 8052

### ACCESSOIRES

Miroir Raggio avec étagère Pass-by et porte-serviette Under en métal Titanio

### MATERIALIEN

Waschbecken Afrodite mit gestreifter Säule in Okite Calacatta Oro 8052  
 Kleinen Hochschrank Sipario lackiert Canapa matt, innen lackiert und Abdeckplatte Okite Calacatta Oro 8052

### ZUBEHÖRE

Spiegel Raggio mit Pass-by Regal und Handtuchhalter Under in Metall Titanio

### MATERIALES

Lavabo Afrodite con columna rayada en Okite Calacatta Oro 8052  
 Minicolumnas Sipario lacadas en Canapa mate con interior lacado y cobertura en Okite Calacatta Oro 8052

### ACCESORIOS

Espejo Raggio con estante Pass-by y toallero Under en metal Titanio

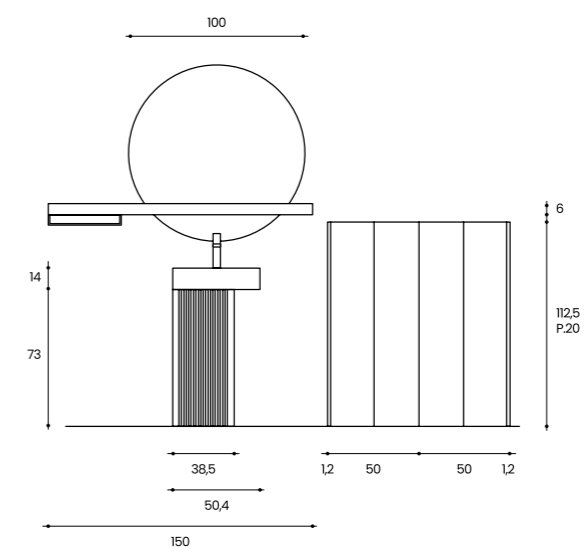

03





Mensola **Pass-by**  
con porta-salviette **Under** in metallo Titanio  
**Pass-by** shelf  
with towel holder **Under** in metal Titanio  
Étagère **Pass-by**  
avec porte-serviette **Under** en métal Titanio  
**Pass-by** Regal  
mit Handtuchhalter **Under** aus Metall Titanio  
Estante **Pass-by**  
con toallero **Under** en metal Titanio



Tre varianti di posizionamento  
del lavabo **Afrodite** sulla sua colonna  
Three variants of positioning  
the **Afrodite** sink on its column  
Trois variantes de positionnement  
du vasque **Afrodite** sur sa colonne  
Drei Varianten der Positionierung  
des **Afrodite** Becken auf seiner Säule  
Tres variantes de colocación  
del lavabo **Afrodite** en su columna

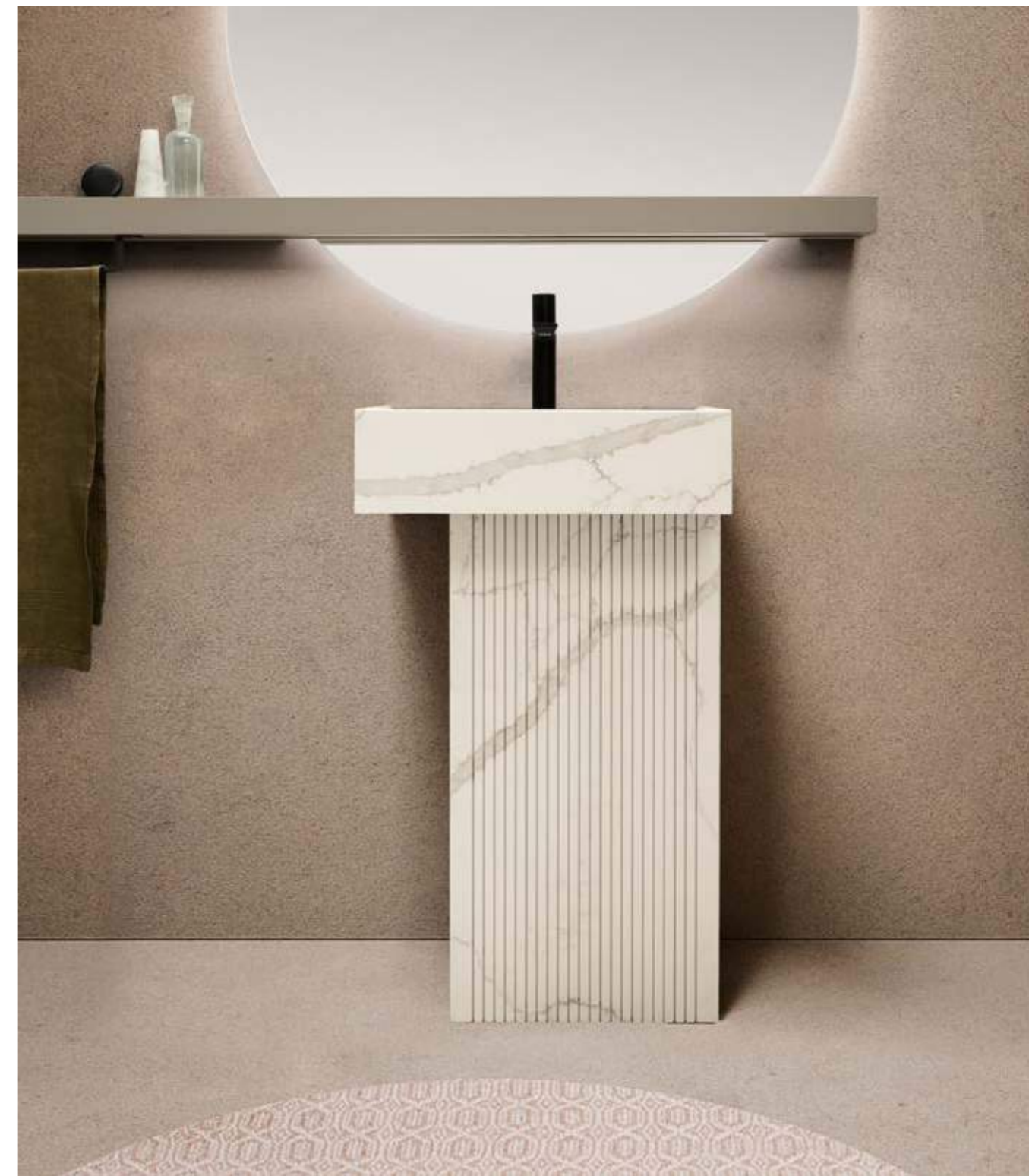



**Colonnine Sipario:**  
la scocca ribassata crea  
un insolito ripiano a pozzetto  
rivestito in Okite Calacatta Oro 8052

**Small-Columns Sipario:**  
the lowered body creates an unusual  
open compartment covered  
in Okite Calacatta Oro 8052

**Petites-colonnes Sipario:**  
la structure abaissée crée  
un compartiment ouvert couvert  
en finition Okite Calacatta Oro 8052

**Small-Columns Sipario:**  
Der abgesenkte Körper schafft  
ein ungewöhnliches offenes Fach,  
das mit Okite Calacatta Oro 8052  
bedeckt ist

**Minicolumnas Sipario:**  
el cuerpo rebajado crea un estante  
inusual en la parte superior revestido  
en Okite Calacatta Oro 8052





# 04

## MATERIALI

Rovere Fiammato Quarzo  
con terminale a giorno laccato Nafta opaco  
Top in Gres Amazonico Slate  
con vasca integrata GGG5

## ACCESSORI

Specchio Lumière  
Barra accessoriata Strike laccata Nafta opaco

## MATERIALS

Rovere Fiammato Quarzo  
with details lacquered Nafta matt  
Top Gres Amazonico Slate  
with integrated sink GGG5

## ACCESSORIES

Mirror Lumière  
and bar Strike lacquered Nafta matt

## MATÉRIAUX

Rovere Fiammato Quarzo  
avec détails laqués Nafta mat  
Plan de toilette en Grès Amazonico Slate  
avec vasque intégrée GGG5

## ACCESSOIRES

Miroir de la série Lumière  
et barre équipée Strike laquée Nafta mat

## MATERIALIEN

Rovere Fiammato Quarzo  
mit Details lackiert Nafta matt  
Top Gres Amazonico Slate  
mit integriertem Waschbecken GGG5

## ZUBEHÖRE

Spiegel Lumière  
und Bar Strike lackiert Nafta matt

## MATERIALES

Rovere Fiammato Quarzo  
con detalles lacados en Nafta mate  
Encimera en Gres Amazonico Slate  
con lavabo integrado GGG5

## ACCESORIOS

Espejo de la serie Lumière  
y barra equipada Strike lacada en Nafta mate

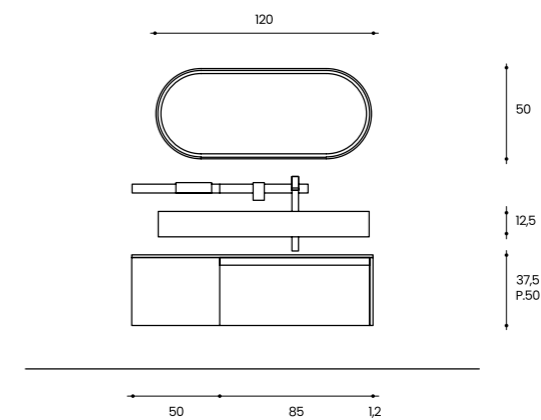







Vasca integrata **GGG5** con la nuova piletta rivestita in Gres  
Integrated sink **GGG5** with the new drain covered in Gres  
Vasque intégrée **GGG5** avec la nouvelle bonde revêtue en Grès  
Integriertn Waschkecken **GGG5** mit dem neuen Abfluss in Gres abgedeckt  
Lavabo integrado **GGG5** con el nuevo desagüe revestido en Gres





Colonne laccate Nafta opaco  
con ante e ripiani in vetro fumé grigio,  
sono corredate di illuminazione integrata  
Columns lacquered Nafta matt  
with doors and shelves in gray smoked glass,  
equipped with integrated lights  
Colonnes laquées en Nafta mat  
avec portes et étagères en verre fumé gris,  
équipées d'éclairage intégré  
Säulen lackiert Nafta matt mit Türen  
und Regalen in grauem Rauchglas,  
ausgestattet mit integrierten Leuchten  
Columnas lacadas en Nafta mate  
con puertas y estantes de cristal ahumado gris,  
equipadas con iluminación integrada



## 05

### MATERIALI

Laccato Luce opaco  
Top e lavabo Poseidone  
in Okite Grigio Sahara 8068

### ACCESSORI

Specchi Sputnik con retroilluminazione  
Lampade Tube

### MATERIALS

Lacquered Luce matt, top  
and sink Poseidone  
in Okite Grigio Sahara 8068

### ACCESSORIES

Mirror Sputnik  
with perimeter light and lamps Tubes

### MATÉRIAUX

Laqué Luce mat,  
plan de toilette et vasque Poseidone  
en Okite Grigio Sahara 8068

### ACCESSOIRES

Miroirs Sputnik  
avec éclairage périmétral et lampes Tube

### MATERIALIEN

Lackiert Luce matt  
Top und Waschbecken Poseidone  
in Okite Grigio Sahara 8068

### ZUBEHÖRE

Spiegel Sputnik  
mit Perimeterlicht und Lampen Tube

### MATERIALES

Lacado en Luce mate  
encimera y lavabo Poseidone  
en Okite Grigio Sahara 8068

### ACCESORIOS

Espejos Sputnik  
con iluminación perimetral y lámparas Tube

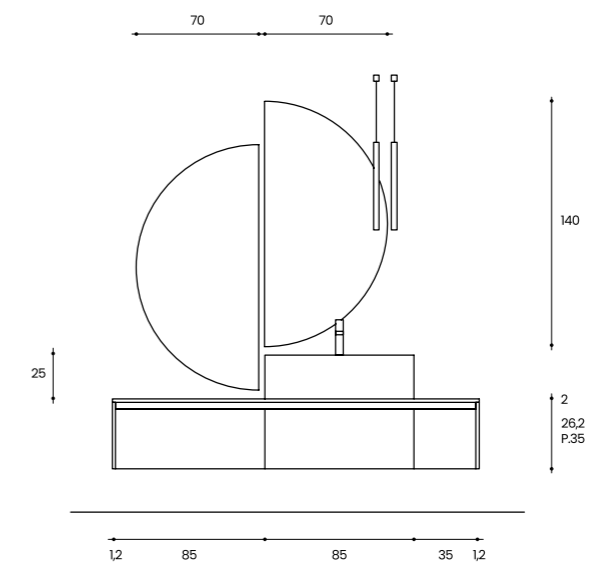





Accessori **Strike** laccati Luce opaco  
Accessories **Strike** lacquered Luce matt  
Accessoires **Strike** laqués en Luce mat  
Zubehör **Strike** lackiert Luce matt  
Accesorios **Strike** lacados en Luce mate





Lavabo **Poseidone**  
in Okite Grigio Sahara 8068  
con piletta rivestita  
Sink **Poseidone**  
in Okite Grigio Sahara 8068  
with covered drain  
Lavabo **Poseidone**  
en Okite Grigio Sahara 8068  
avec bonde revêtue  
Waschbecken **Poseidone**  
in Okite Grigio Sahara 8068  
mit abgedecktem Abfluss  
Lavabo **Poseidone**  
en Okite Grigio Sahara 8068  
con desagüe revestido





## 06

### MATERIALI

DOGATO laccato Bosco opaco con particolari Oro  
Top in Geacryl color matt Bosco sp.6 cm  
con vasca integrata LWW5 e alzatina sagomata  
per specchio Raggio

### ACCESSORI

Specchio Raggio diametro 120 cm

### MATERIALS

DOGATO Bosco matt with details Oro  
Top th.6cm Geacryl color matt Bosco  
with integrated washbasin LWW5  
and upstand shaped for mirror Raggio

### ACCESSORIES

Mirror Raggio diam. 120 cm

### MATÉRIAUX

DOGATO Bosco mat avec détails en Oro  
Plan de toilette en Geacryl color matt Bosco  
ép. 6 cm avec vasque intégrée LWW5  
et dossier façonné pour le miroir Raggio

### ACCESSOIRES

Miroir Raggio diam. 120 cm

### MATERIALIEN

DOGATO Bosco matt mit Details Oro  
Top th.6 cm Geacryl color matt Bosco  
mit integriertem Waschbecken LWW5  
und Upstand geformt für Spiegel Raggio

### ZUBEHÖRE ZUBEHÖRE

Spiegel Raggio diam.120 cm

### MATERIALES

DOGATO Bosco opaco con detalles en Oro  
Encimera en Geacryl color matt Bosco  
de 6 cm de espesor con lavabo integrado LWW5 y  
alzada moldeada para el espejo Raggio

### ACCESORIOS

Espejo Raggio diam. 120 cm

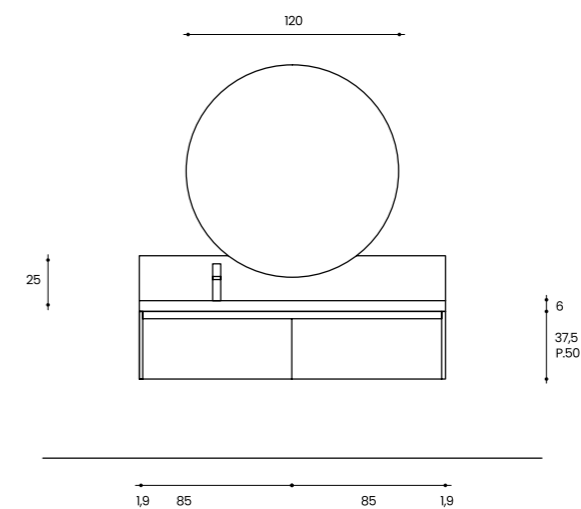







Vasca integrata **LWW5**  
P.53: fianco di finitura  
con lavorazione DOGATO come i frontali  
Integrated sink **LWW5**  
P.53: Side panel  
with DOGATO finishing as fronts  
Vasque intégrée **LWW5**  
P.53: Côté de finition  
en DOGATO comme les façades  
Integrierten Waschbecken **LWW5**  
P.53: Abschlussseite aus DOGATO  
wie Fassaden  
Lavabo integrado **LWW5**  
P.53: el costado final  
DOGATO como los frontales





Elementi a giorno con struttura in metallo  
laccato Bosco opaco e interno Oro opaco  
Open elements with metal structure  
lacquered Bosco and Oro matt  
Éléments ouverts avec structure  
en métal laqué Bosco et Oro mat  
Offene Elemente mit Metallstruktur  
Lackiert Bosco und Oro matt  
Elementos abiertos con estructura  
en metal lacado Bosco y Oro mate



## 07

### MATERIALI

Mezzafiamma Naturale  
Top in Tecnoril scatolato h. 12,5  
con vasca integrata AW15  
e asola porta-salviette laterale

### ACCESSORI

Specchio Raggio retroilluminato  
Mensola Pass-By laccata Bianco opaco  
Lampade a sospensione Tube in metallo Bianco

### MATERIALS

Mezzafiamma Naturale  
boxed top Tecnoril H.12.5 with integrated sink AW15  
and integrated towel holder

### ACCESSORIES

Mirror Raggio with shelf Pass-By White matt  
Lamps Tube metal White

### MATÉRIAUX

Mezzafiamma Naturale  
plan de toilette en Tecnoril H.12,5  
avec vasque intégrée AW15 et découpe  
pour porte-serviette latéral

### ACCESSOIRES

Miroir Raggio avec étagère Pass-By Bianco opaco  
Lampes suspendues Tube en métal Blanc

### MATERIALIEN

Mezzafiamma Naturale  
Boxed Top Tecnoril H.12.5  
mit integriertem Waschbecken AW15  
und integriertem Handtuchhalter

### ZUBEHÖRE

Spiegel Raggio mit Regal Pass-By Bianco matt  
Lampen Tube Metall Weiß

### MATERIALES

Mezzafiamma Naturale  
encimera en Tecnoril H.12,5  
con lavabo integrado AW15  
y ranura toallero lateral

### ACCESORIOS

Espejo Raggio con estante Pass-By  
en Bianco opaco  
Lámparas colgantes Tube en metal Blanco

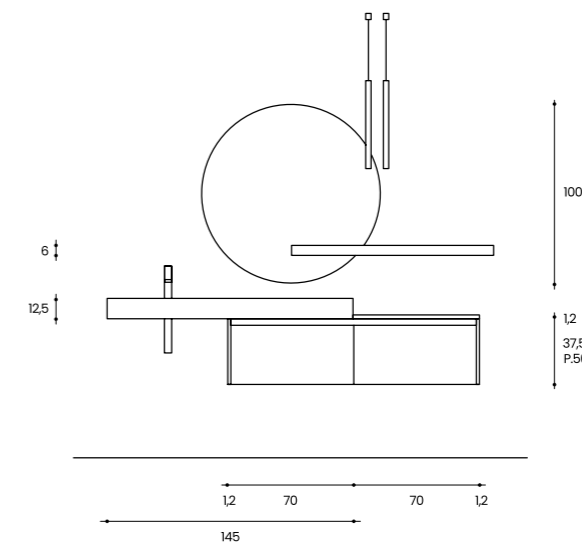





La mensola **Pass-By** sagomata  
in sovrapposizione allo specchio  
The shaped **Pass-By** shelf  
overlaps the mirror  
L'étagère **Pass-By** moulée  
pour se superposer au miroir  
Das geformte **Pass-By**-Regal  
überlappt den Spiegel  
El estante **Pass-By** moldeado  
se sobrepone al espejo



La colonna **Opera** con elemento a giorno  
in Mezzafiamma Naturale  
in versione laundry

The **Opera** column with open element  
Mezzafiamma Naturale  
in the laundry version

Colonne **Opera** avec un élément ouvert  
en Mezzafiamma Naturale  
en version laundry

Die **Opera** Säule mit offenem Element  
Mezzafiamma Naturale  
in der Laundry version

La columna **Opera** con un elemento abierto  
en Mezzafiamma Naturale  
en versión laundry





# 08

## MATERIALI

Lavabo Zeus con decoro Mondrian realizzato in Okite Calacatta Oro 8052  
 Colonnine Sipario laccate Canapa opaco con interno laccato e copertura in Okite Calacatta Oro 8052

## ACCESSORI

Specchio Raggio con mensola Pass-by e porta-salviette Under in metallo Titanio

## MATERIALS

Washbasin Zeus with decoration Mondrian from Okite Calacatta Oro 8052,  
 Small columns Sipario lacquered Canapa matt, lacquered inside and cover top Okite Calacatta Oro 8052

## ACCESSORIES

Mirror Raggio with shelf Pass-by and towel rail Under in metal Titanio

## MATÉRIAUX

Lavabo Zeus avec décoration Mondrian réalisé en Okite Calacatta Oro 8052  
 Petites colonnes Sipario laquées en Canapa mat avec intérieur laqué et couverture en Okite Calacatta Oro 8052

## ACCESSOIRES

Miroir Raggio avec étagère Pass-by et porte-serviette Under en métal Titanio

## MATERIALIEN

Waschbecken Zeus mit Dekoration Mondrian von Okite Calacatta Oro 8052  
 Kleine Säulen Sipario lackiert Canapa matt, lackiert innen und Abdeckplatte Okite Calacatta Oro 8052

## ZUBEHÖRE

Spiegel Raggio mit Regal Pass-by und Handtuchhalter Under in Metall Titanio

## MATERIALES

Lavabo Zeus con decoración Mondrian realizado en Okite Calacatta Oro 8052  
 Minicolumnas Sipario lacadas en Canapa opaco con interior lacado y cobertura en Okite Calacatta Oro 8052

## ACCESORIOS

Espejo Raggio con estante Pass-by y toallero Under en metal Titanio

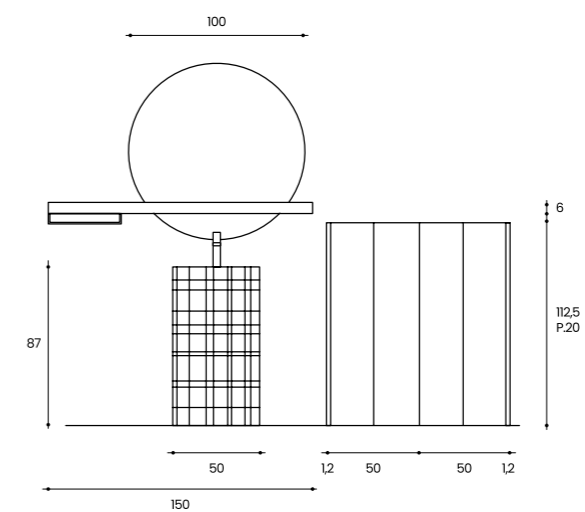







Lavabo monolite **Zeus** in Okite Calacatta Oro 8052  
e colonnina **Sipario** laccata Canapa opaco con copertura nella stessa variante di Okite  
**Zeus** monolith washbasin in Okite Calacatta Oro 8052  
and column **Sipario** lacquered Canapa matt with cover in the same variant of Okite  
Lavabo monolithe **Zeus** en Okite Calacatta Oro 8052  
et petite colonne **Sipario** laqué Canapa mat avec couverture dans la meme variante en Okite  
**Zeus** Monolith Waschbecken in Okite Calacatta Oro 8052 und Canapa matt lackiert **Sipario**  
kleine Säule mit Abdeckung in der gleichen Okite Finish  
Lavabo monolita **Zeus** en Okite Calatatta Oro 8052 y minicolumna **Sipario** lacada Canapa mate  
con cobertura en la misma variante de Okite



## 08b

Variante di **Zeus** in Okite Calacatta Oro 8052  
 con frontale in Rovere cannettato Grano  
 Specchio **Briks** con satinatura  
 e illuminazione integrata  
 Version of **Zeus** in Okite Calacatta Oro 8052  
 with front in Rovere cannettato Grano  
 Mirror **Briks** with satin finish and integrated light  
 Variante de **Zeus** en Okite Calacatta Oro 8052  
 avec façade en Rovere cannettato Grano  
 Miroir **Briks** avec satinage et éclairage intégré  
 Version von **Zeus** in Okite Calacatta Oro 8052  
 mit Front in Rovere cannettato Grano  
 Spiegel **Briks** mit satinierem Finish und integriertem Licht  
 Variante de **Zeus** en Okite Calacatta Oro 8052  
 con frontal en Rovere cannettato Grano  
 Espejo **Briks** con parte satinada y iluminación integrada

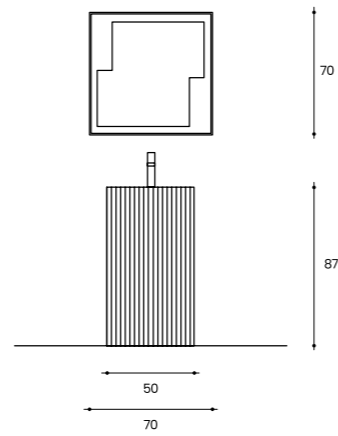

## 08b

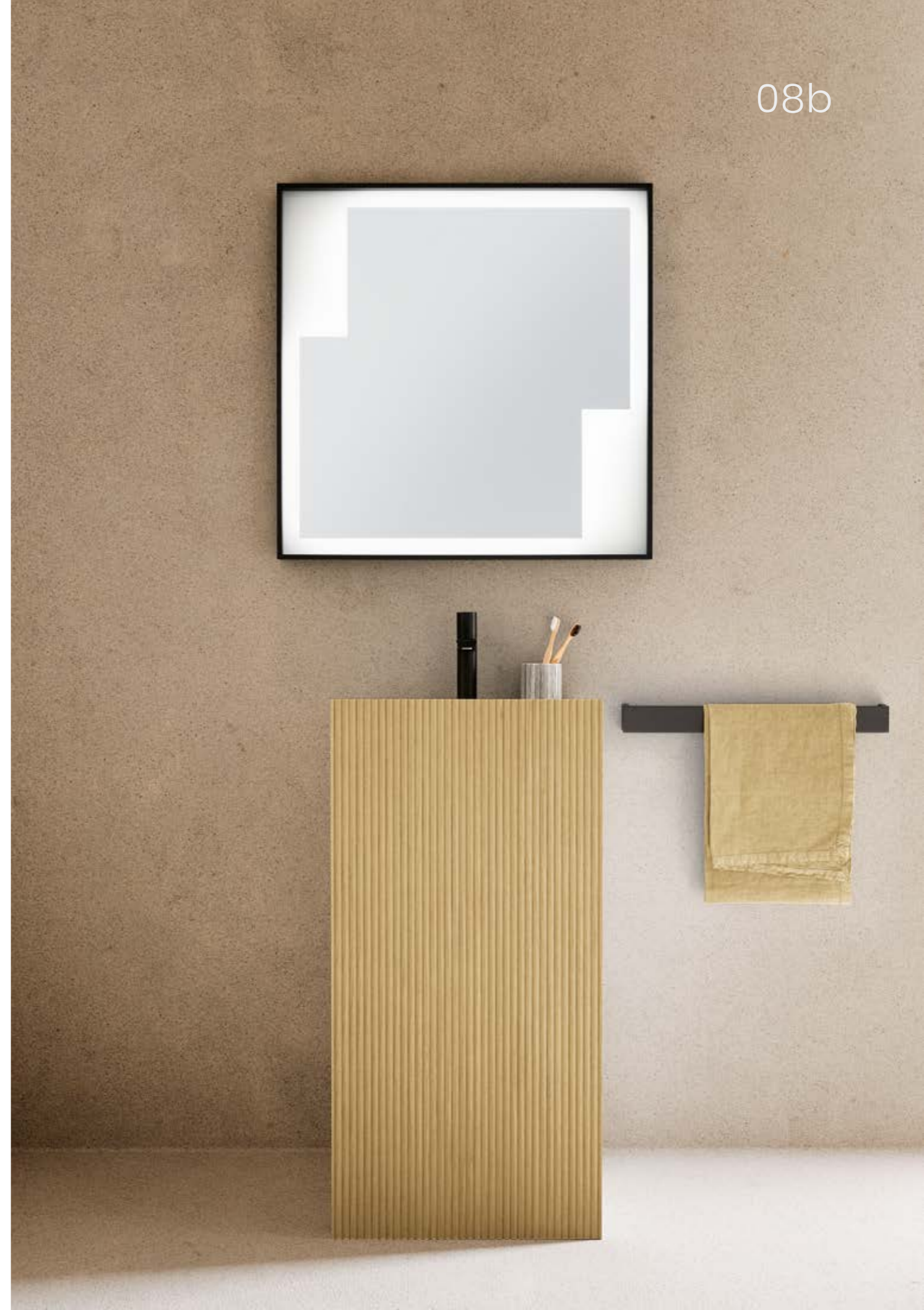



# 09

## MATERIALI

DOGATO Grigio opaco  
con particolari Grafite opaco  
Top in Geacryl color matt Grigio  
con vasca integrata LE15  
e asola porta-salviette laterale

## ACCESSORI

Specchi Loop  
Barra accessoriata Strike laccata Grafite opaco  
Elementi a giorno Ice in vetro fumé grigio

## MATERIALS

DOGATO Grigio matt with details Grafite matt  
Top Geacryl color matt Grigio  
with integrated washbasin LE15  
and integrated towel rail

## ACCESSORIES

Mirror Loop  
and Bar Strike painted Grafite  
Open elements Ice in gray smoked glass

## MATÉRIAUX

DOGATO Grigio mat avec détails Grafite mat  
Plan de toilette en Geacryl color matt Grigio  
avec vasque intégrée LE15 et découpe  
pour porte-serviette latéral

## ACCESSOIRES

Miroirs Loop  
Barre équipée Strike laquée Grafite  
Éléments ouverts Ice en verre fumé gris

## MATERIALIEN

DOGATO Grigio matt mit Details Grafite matt  
Top Geacryl color matt Grigio mit integriertem  
Waschbecken LE15 und integriertem  
Handtuchhalter

## ZUBEHÖRE

Spiegel Loop  
Bar Strike lackiert Grafite  
Open Elemente Ice in grau Rauchglas

## MATERIALES

DOGATO Grigio opaco con detalles en Grafite mate  
Encimera en Geacryl color matt Grigio  
con lavabo integrado LE15 y ranura toallero lateral

## ACCESORIOS

Espejos Loop  
Barra equipada Strike lacada en Grafite  
Elementos abiertos Ice en cristal ahumado gris

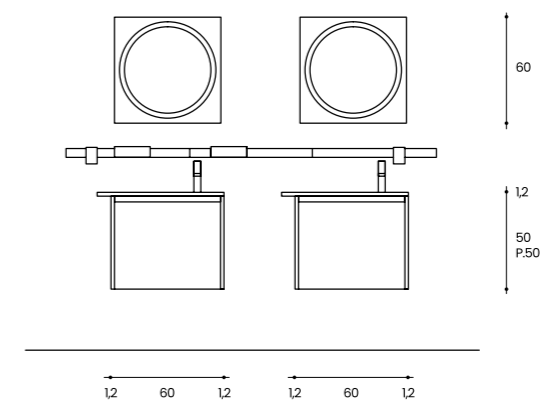





La barra accessoriata **Strike**  
 è disponibile in tutta la gamma  
 colori opachi Archeda  
 The equipped **Strike** bar  
 is available in the entire range  
 of Archeda matt colors  
 La barre équipée **Strike**  
 est disponible dans toute la gamme  
 de couleurs mates Archeda  
 Die ausgestattete **Strike**-Bar  
 ist in der gesamten Palette  
 der matt Archeda-Farben erhältlich  
 La barra equipada **Strike**  
 está disponible en toda la gama  
 de colores mates Archeda



Asola porta-salviette laterale  
 Integrated lateral towel holder  
 Découpe pour porte-serviette latéral  
 Integrierter seitlicher Handtuchhalter  
 Ranura toallero lateral

Elementi a giorno **Ice** in vetro fumé grigio  
Open elements **Ice** in gray smoked glass  
Éléments ouverts **Ice** en verre fumé gris  
Offene Elemente **Ice** in grauem Rauchglas  
Elementos abiertos **Ice** en cristal ahumado gris





# 10

## MATERIALI

Laccato Ambra opaco con particolari Titanio  
 Piano in Geacryl color matt Ambra  
 Lavabo in appoggio Smart 54  
 in ceramica nera

## ACCESSORI

Pensili Opera con boiserie in Poronocce Nazionale  
 Mensole in metallo Titanio  
 Specchio Profilo in alluminio nero  
 Lampada Walk nera

## MATERIALS

Laquered Ambra matt with details Titanio  
 Top Geacryl color matt Ambra  
 with sink mod. Smart 54 ceramic black

## ACCESSORIES

Wall units Opera  
 with boiserie Poronocce Nazionale  
 and metal shelves Titanio  
 Mirror Profilo black and lamp Walk black

## MATÉRIAUX

Laqué Ambra mat avec détails Titanio  
 Plan de toilette en Geacryl color matt Ambra  
 avec vasque à poser Smart 54 en céramique noire

## ACCESSOIRES

Meubles hauts Opera avec boiserie  
 en Poronocce Nazionale  
 et étagères en métal Titanio  
 Miroir Profilo en cadre aluminium noir  
 et lampe Walk Noire

## MATERIALIEN

Lackiert Ambra matt mit Details Titanio  
 Top Geacryl color matt Ambra  
 mit Waschbecken mod  
 Smart 54 Keramik schwarz

## ZUBEHÖRE

Hängeschränke Opera  
 mit Boiserie Poronocce Nazionale  
 und Metallregale Titanio  
 Spiegel Profilo schwarz  
 und Lampe Walk schwarz

## MATERIALES

Lacado en Ambra mate con detalles en Titanio  
 Encimera en Geacryl color matt Ambra  
 con lavabo sobre encimera Smart 54  
 en cerámica negra

## ACCESORIOS

Colgantes Opera con boiserie  
 en Poronocce Nazionale  
 y estantes en metal Titanio  
 Espejo perfil aluminio negro  
 y lámpara Walk negra

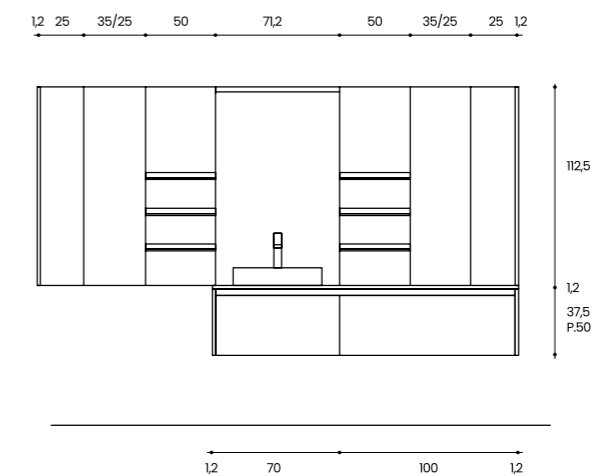





10



Lavabo **Smart 54** in ceramica nera opaca  
 Ceramic Sink **Smart 54** in black matt  
 Vasque à poser **Smart 54** en céramique noire mate  
 Keramik Waschbecken **Smart 54** in schwarz matt  
 Lavabo **Smart 54** en cerámica negra mate



Pensile **Opera** con illuminazione laterale integrata  
 Opera wall unit with integrated side lights  
 Meuble haut **Opera** avec éclairage latéral intégré  
 Opera Hängeschrank mit integrierten Seitenleuchten  
 Colgante **Opera** con iluminación lateral integrada



# 11

## MATERIALI

Poronocce Latte  
con particolari laccati Liquirizia opaco  
Top con vasca integrata GHH5  
e fianchetti laterali in Gres Fokos Terra

## ACCESSORI

Specchio Lumière  
Pensili Opera

## MATERIALS

Poronocce Latte  
with details Liquirizia matt  
Top with integrated sink GHH5  
and side panels in Gres Fokos Terra

## ACCESSORIES

Mirror Lumière  
Opera wall units

## MATÉRIAUX

Poronocce Latte  
avec détails laqués Liquirizia mat  
Plan de toilette avec vasque intégrée GHH5  
et panneaux latéraux en Grés Fokos Terra

## ACCESSOIRES

Miroir de la série Lumière  
Meubles hauts Opera

## MATERIALIEN

Poronocce Latte  
mit Details Liquirizia matt  
Top mit integriertem Waschbecken GHH5  
und Seitenteilen in Gres Fokos Terra

## ZUBEHÖRE

Spiegel Lumière  
Opera Oberschränke

## MATERIALES

Poronocce Latte  
con detalles lacados en Liquirizia mate  
Encimera con lavabo integrado GHH5  
y laterales en gres Fokos Terra

## ACCESORIOS

Espejo de la serie Lumière  
Colgantes Opera

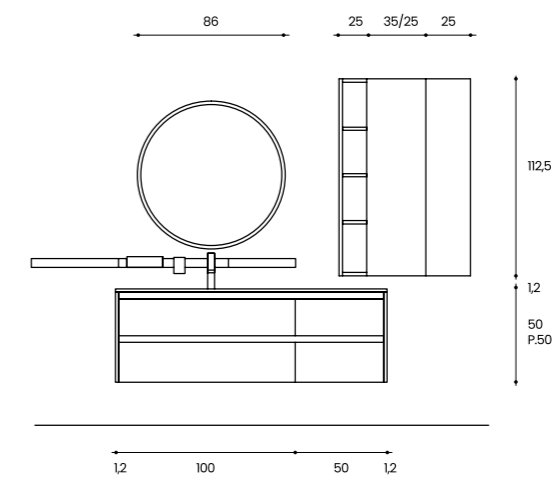





Accessori **Strike** laccati Liquirizia opaco  
Accessories **Strike** lacquered Liquirizia matt  
Accessoires **Strike** laqués en Liquirizia mat  
Zubehör **Strike** lackiert Liquirizia matt  
Accesorios **Strike** lacados en Liquirizia mate



Pensile **Opera** in Poronoce Latte  
con pensile a giorno laccato Liquirizia opaco  
**Opera** wall unit in Poronoce Latte  
with open wall unit lacquered Liquirizia matt  
Meuble haut **Opera** en Poronoce Latte  
avec meuble ouvert laqué en Liquirizia mat  
**Opera** Hängeschrank in Poronoce Latte  
mit offener Hängeschrank lackiert Liquirizia matt  
Colgante **Opera** en Poronoce Latte  
con mueble abierto lacado en Liquirizia mate





# 12

## MATERIALI

Frontali e fianchi in RIGATO Fard opaco  
 Top laccato Fard opaco  
 Lavabi Afrodite  
 in Okite Nero Marquinia 8069

## ACCESSORI

Specchi Briks con cornice in alluminio nero  
 e illuminazione integrata

## MATERIALS

Fronts and finishing sides  
 RIGATO Fard matt  
 Lacquered top  
 with wasbsins Afrodite  
 in Okite Nero Marquinia 8069

## ACCESSORIES

Mirrors Briks  
 with black aluminum frame  
 and integrated light

## MATÉRIAUX

Façades et côtés de finition  
 en Fard RIGATO mat  
 Plan de toilette laqué  
 avec vasques Afrodite  
 en Okite Nero Marquinia 8069

## ACCESSOIRES

Miroirs Briks  
 avec cadre en aluminium noir  
 et éclairage intégré

## MATERIALIEN

Fronten und Seitenteile  
 aus RIGATO Fard matt  
 Lackiertes Top mit Afrodite Waschbecken  
 aus Okite Nero Marquinia 8069

## ZUBEHÖRE

Briks Spiegel  
 mit schwarzem Aluminiumrahmen  
 und integrierter Beleuchtung

## MATERIALES

Frontales y laterales de acabado  
 en RIGATO Fard mate  
 Encimera lacada con lavabos Afrodite  
 en Okite Nero Marquinia 8069

## ACCESORIOS

Espejos Briks con marco de aluminio negro  
 y iluminación integrada

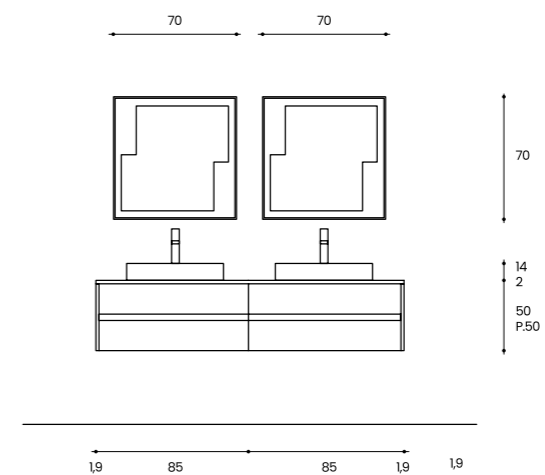







Specchio **Briks** con cornice in alluminio nero,  
decorazione satinata e illuminazione integrata  
Mirror **Briks** with black aluminum frame,  
satin finish and integrated light  
Miroir **Briks** avec cadre en aluminium noir,  
décoration satinée et éclairage intégré  
Spiegel **Briks** mit schwarzem Aluminiumrahmen  
Satinierung und integriertem Licht  
Espejo **Briks** con marco de aluminio negro  
decoración satinada y iluminación integrada

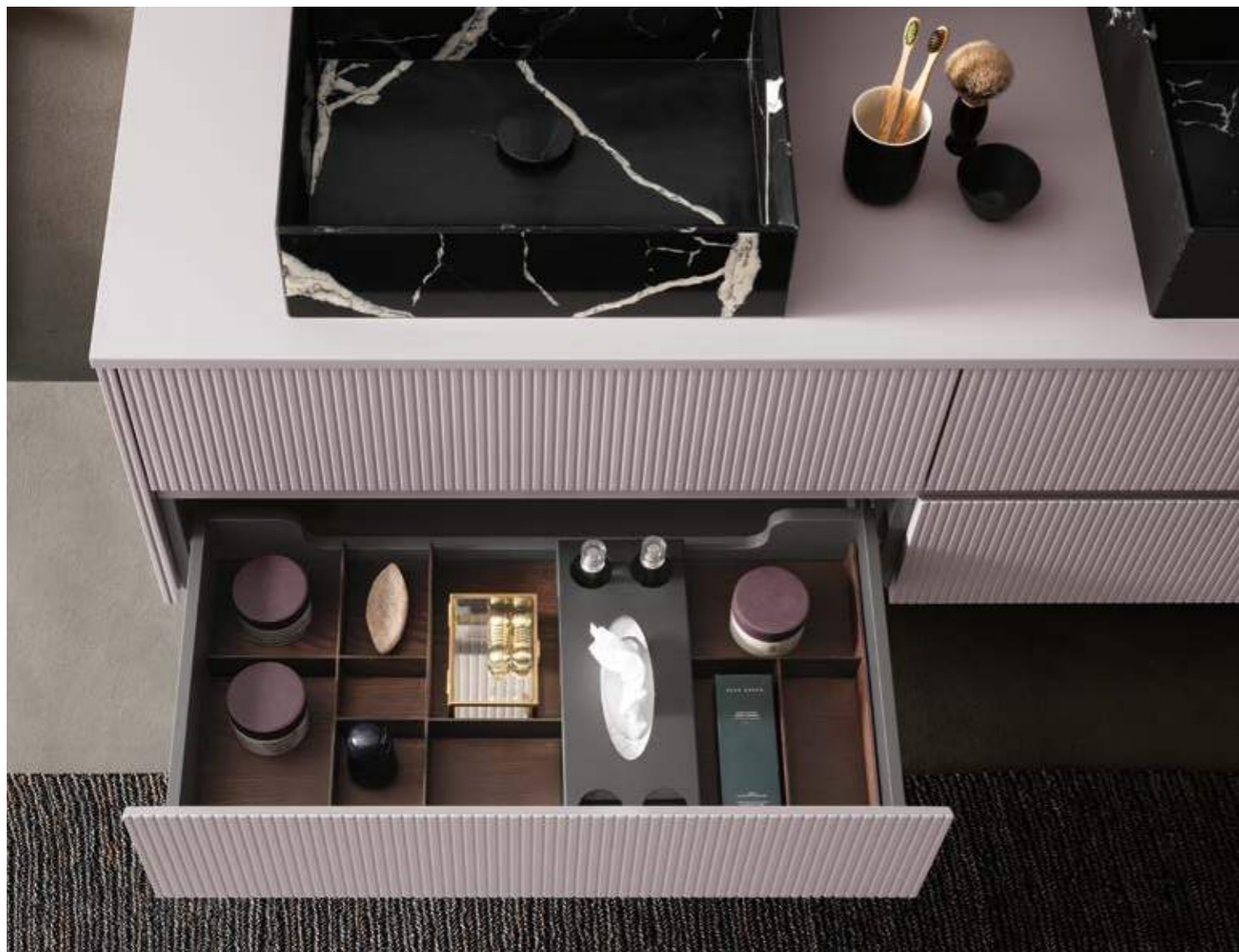

Accessori per cassetti **Inside**  
Drawer accessories **Inside**  
Accessoires pour tiroirs **Inside**  
Schubladenzubehör **Inside**  
Accesorios para cajones **Inside**





# 13

## MATERIALI

Lavabo Rock-Art  
in Geacryl color matt Nebbia  
Colonnine Sipario in Mezzafiamma Grigio,  
interno scocca laccato Nebbia opaco

## ACCESSORI

Specchio Briks

## MATERIALS

Washbasin Rock-Art  
in Geacryl color matt Nebbia  
Small high cabinet Sipario  
in Mezzafiamma Grigio  
with inside lacquered Nebbia matt

## ACCESSORIES

Mirror Briks

## MATÉRIAUX

Lavabo Rock-Art  
en Geacryl color matt Nebbia  
Petites colonnes Sipario  
en Mezzafiamma Grigio  
avec intérieur laqué Nebbia mat

## ACCESSOIRES

Miroir Briks

## MATERIALIEN

Washbecken Rock-Art  
in Geacryl color matt Nebbia  
Kleiner Hochschrank Sipario  
in Mezzafiamma Grigio  
mit innen lackiertem Nebbia matt

## ZUBEHÖRE

Spiegel Briks

## MATERIALES

Lavabo Rock-Art  
en Geacryl color matt Nebbia  
Minicolumnas Sipario  
en Mezzafiamma Grigio  
con interior lacado en Nebbia mate

## ACCESORIOS

Espejo Briks

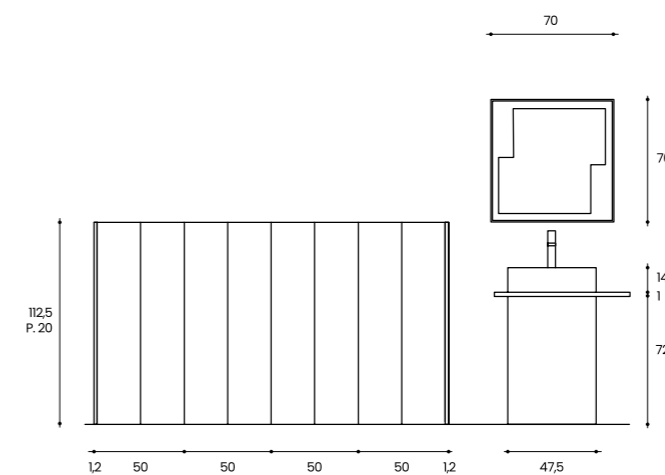

13





**Rock-On.** A destra: **Rock-Art**  
**Rock-On.** On the right: **Rock-Art**  
**Rock-On.** À droite : **Rock-Art**  
**Rock-On.** Rechts: **Rock-Art**  
**Rock-On.** A la derecha: **Rock-Art**



**Rock-Art** con inserto in Okite Nero Marquinia 8069  
**Rock-Art** with insert in Okite Nero Marquinia 8069  
**Rock-Art** avec insert en Okite Nero Marquinia 8069  
**Rock-Art** with insert in Okite Nero Marquinia 8069  
**Rock-Art** con inserción en Okite Nero Marquinia 8069



Colonnine **Sipario**: scomparto ribassato e copertura nella variante laccata Nebbia opaco  
 P.109: in Okite Nero Marquinia 8069  
 Small-Columns **Sipario**: open compartment covered with top Nebbia matt  
 P109: version with Okite Nero Marquinia 8069  
 Petites colonnes **Sipario**: compartiment ouvert recouvert en Nebbia mat  
 P109: version en Okite Nero Marquinia 8069  
 Small-Columns **Sipario**: offenes Fach mit Deckel Nebbia matt  
 P109: Ausführung mit Okite Nero Marquinia 8069  
 Minicolumnas **Sipario** con el estante en la variante lacada Nebbia mate  
 P109: en Okite Nero Marquinia 8069





# 14

## MATERIALI

Mezzafiamma Grigio  
 con particolari laccati Bianco opaco  
 Top in Gres Ardesia Bianco a spacco  
 Lavabo Pop-Up in Deimos bianco opaco

## ACCESSORI

Specchio Alba retroilluminato  
 Mensola Pass-By

## MATERIALS

Mezzafiamma Grigio  
 with details Bianco matt lacquered  
 Top Gres Ardesia Bianco a spacco  
 and sink Pop-Up Deimos White matt

## ACCESSORIES

Mirror Alba with shelf Pass-By

## MATÉRIAUX

Mezzafiamma Grigio  
 avec détails laqués Bianco mat  
 Plan de toilette en Grès Ardesia Bianco a spacco  
 et vasque Pop-Up en Deimos blanc mat

## ACCESSOIRES

Miroir Alba avec étagère Pass-By

## MATERIALIEN

Mezzafiamma Grigio  
 mit Details Bianco mat lackiert  
 Top Gres Ardesia Bianco a Spacco  
 und Waschbecken Pop-Up Deimos Weiß matt

## ZUBEHÖRE

Spiegel Alba mit Regal Pass-By

## MATERIALES

Mezzafiamma Grigio  
 con detalles lacados en Bianco mate  
 Encimera en Gres Ardesia Bianco a spacco  
 y lavabo Pop-Up en Deimos blanco mate

## ACCESORIOS

Espejo Alba con estante Pass-By

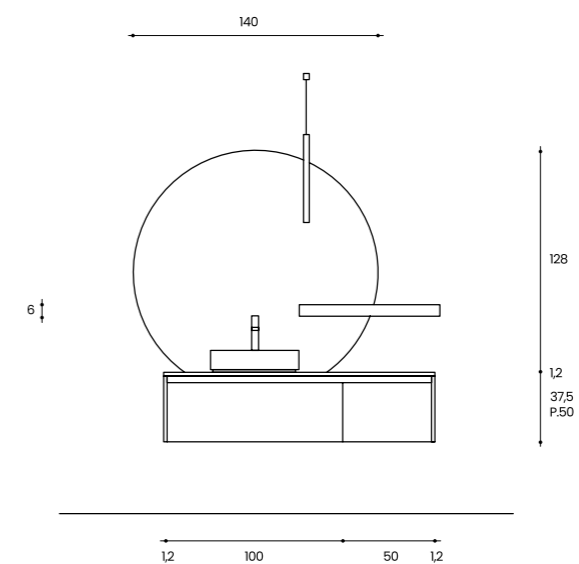







Lavabo **Pop-Up** in Deimos bianco opaco  
Sink **Pop-Up** in Deimos white matt  
Vasque à poser **Pop-Up** en Deimos blanc mat  
Waschbecken **Pop-Up** in Deimos Weiß matt  
Lavabo **Pop-Up** en Deimos bianco mate



Pensili in Mezzafiamma Grigio  
con elementi a giorno **Square**  
Wall units Mezzafiamma Grigio  
with open elements **Square**  
Meubles hauts en Mezzafiamma Grigio  
avec éléments ouverts **Square**  
Schrankwand Mezzafiamma Grigio  
mit offenen Elementen **Square**  
Alacenas en Mezzafiamma Grigio  
con elementos abiertos **Square**





Variante con specchio **Filux** con led perimetrale, lampada frontale  
Variant with **Filux** mirror with perimeter LED and frontlamp  
Variante avec miroir **Filux** avec led perimetral et lampe frontale  
Variante mit **Filux** Spiegel mit Perimeter LED und frontlamp  
Variante con espejo **Filux** con led perimetral y lámpara frontal



# 15

## MATERIALI

Rovere Fiammato Agata  
con particolari laccati Mattone opaco  
Top Rovere Fiammato Agata  
con lavabo in appoggio Round  
in ceramica opaca Tortora

## ACCESSORI

Specchio Pop con lampada verticale Star

## MATERIALS

Rovere Fiammato Agata  
with details lacquered Mattone matt  
Top Rovere Fiammato Agata  
with ceramic washbasin Round Tortora matt

## ACCESSORIES

Mirror Pop with lamp Star

## MATÉRIAUX

Rovere Fiammato Agata  
avec détails laqués Mattone mat  
Plan de toilette en Rovere Fiammato Agata  
avec vasque à poser Round  
en céramique mat Tortora

## ACCESSOIRES

Miroir Pop avec lampe Star

## MATERIALIEN

Rovere Fiammato Agata  
mit Details lackiert Mattone matt  
Top Rovere Fiammato Agata  
mit Keramikwaschbecken Round Tortora matt

## ZUBEHÖRE

Spiegel Pop mit Lampe Star

## MATERIALES

Rovere Fiammato Agata  
con detalles lacados en Mattone mate  
Encimera Rovere Fiammato Agata  
con lavabo sobre encimera Round  
en cerámica matt Tortora

## ACCESORIOS

Espejo Pop con lámpara Star

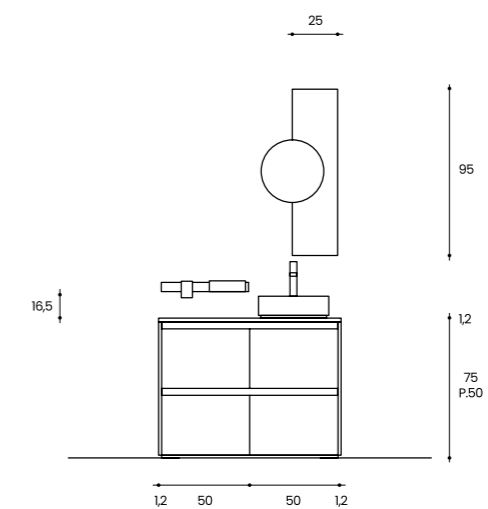

15





Pensile **Opera** con illuminazione laterale integrata  
**Opera** wall unit with integrated side light  
Meuble haut **Opera** avec éclairage latéral intégré  
**Opera** Hängeschrank mit integriertem Seitenlicht  
Colgante **Opera** con iluminación lateral integrada



Lampada verticale **Star** per specchio **Pop**  
Vertical lamp **Star** for mirror **Pop**  
Lampe verticale **Star** pour miroir **Pop**  
Vertikale Lampe **Star** für Spiegel **Pop**  
Lámpara vertical **Star** para espejo **Pop**





# 16

## MATERIALI

Poronocce Nazionale  
con particolari laccati Canapa opaco  
Top scatolato con lavabo Blues  
in Geacryl color matt Canapa

## ACCESSORI

Specchio Lumière

## MATERIALS

Poronocce Nazionale  
with details lacquered Canapa matt  
Boxed top with sink Blues  
in Geacryl color matt Canapa

## ACCESSORIES

Mirror Lumière

## MATÉRIAUX

Poronocce Nazionale  
avec des détails laqués Canapa mat  
Plan de toilette avec lavabo Blues  
en Geacryl color matt Canapa

## ACCESSOIRES

Miroir Lumière

## MATERIALIEN

Poronocce Nazionale  
mit Details lackiert Canapa matt  
Boxed Top mit Waschbecken Blues  
in Geacryl color matt Canapa

## ZUBEHÖRE

Spiegel Lumière

## MATERIALES

Poronocce Nazionale  
con detalles lacados en Canapa mate  
Encimera con lavabo Blues  
en Geacryl color matt Canapa

## ACCESORIOS

Espejo Lumière

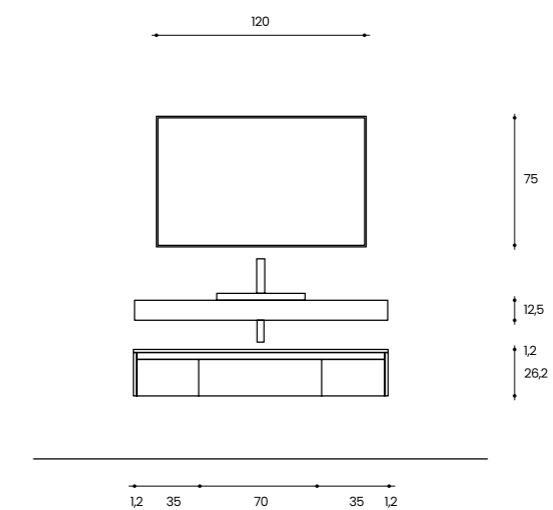







Lavabo ad incasso sopra-piano **Blues**  
in Geacryl color matt Canapa  
Recessed over top sink **Blues**  
in Geacryl color matt Canapa  
Vasque encastrée **Blues**  
en Geacryl color matt Canapa  
Einbauwaschbecken **Blues**  
in Geacryl color matt Canapa  
Lavabo **Blues** sobre encimera  
en Geacryl color matt Canapa

Gioco di pensili a giorno  
e ante chiuse di diverse dimensioni  
Composition of open wall units  
and closed doors of different sizes  
Jeu de meubles hauts ouverts  
et de portes fermées de différentes dimensions  
Zusammensetzung von offenen Schrankwänden  
und geschlossenen Türen in verschiedenen Größen  
Juego de muebles colgantes abiertos  
y puertas cerradas de diferentes medidas



# Tulle\_Vasche



Vasca **Milady**



Vasca **Aquarius**



Vasca **Eclipse**



Vasca **Milord**

# Tulle\_highlights

Porta-salviette **Under** per mensola **Pass-By** \_P.10  
Towel holder **Under** for **Pass-By** shelf \_P.10  
Porte-serviettes **Under** pour étagère **Pass-By** \_P.10  
Handtuchhalter **Under** für Regal **Pass-By** \_P.10  
Toallero **Under** para estante **Pass-By** \_P.10



Specchio **Lumière**, Accessori **Strike** laccati \_P.92  
Mirror **Lumière**, Accessories **Strike** lacquered \_P.92  
Miroir de la série **Lumière**, Accessoires **Strike** laqués \_P.92  
Spiegel **Lumière**, Zubehör **Strike** lacquered \_P.92  
Espejo de la serie **Lumière**, Accesorios **Strike** lacados \_P.92



Specchio **Filux** con led perimetrale e lampada frontale \_P.118 · 119  
**Filux** mirror with perimeter LED and front lamp \_P.118 · 119  
Miroir **Filux** avec led perimetral et lampe frontale \_P.118 · 119  
**Filux** Spiegel mit Perimeter LED und frontlamp \_P.118 · 119  
**Filux** con led perimetral y lámpara frontal \_P.118 · 119



Colonnine **Sipario** \_P.108  
Small-Columns **Sipario** \_P.108  
Petites colonnes **Sipario** \_P.108  
Small-Columns **Sipario** \_P.108  
Minicolumnas **Sipario** \_P.108



Lavabo **Afrodite** con colonna rigata in Okite Calacatta oro 8052 \_P.24  
**Afrodite** washbasin with striped column in Okite Calacatta Oro 8052 \_P.24  
Vasque **Afrodite** avec colonne rayée en Okite Calacatta Oro 8052 \_P.24  
Waschbecken **Afrodite** mit gestreifter Säule in Okite Calacatta Oro 8052 \_P.24  
Lavabo **Afrodite** con columna rayada en Okite Calacatta Oro 8052 \_P.24



Lavabo **Poseidone** in Okite Grigio Sahara 8068 \_P.43  
Sink **Poseidone** in Okite Grigio Sahara 8068 \_P.43  
Vasque **Poseidone** en Okite Grigio Sahara 8068 \_P.43  
Waschbecken **Poseidone** in Okite Grigio Sahara 8068 \_P.43  
Lavabo **Poseidone** en Okite Grigio Sahara 8068 \_P.43



Pensile **Opera** con illuminazione laterale integrata \_P.125  
**Opera** wall unit with integrated side light \_P.125  
Meuble haut **Opera** avec éclairage latéral intégré \_P.125  
**Opera** Hängeschränk mit integriertem Seitenlicht \_P.125  
Colgante **Opera** con iluminación lateral integrada \_P.125



Mensola **Pass-by** con illuminazione led integrata \_P.10 · 60 · 66  
The **Pass-by** shelf with integrated LED light \_P.10 · 60 · 66  
Étagère **Pass-by** avec éclairage led intégré \_P.10 · 60 · 66  
**Pass-by**-Regal mit integriertem LED-Licht \_P.10 · 60 · 66  
Estante **Pass-by** con iluminación LED integrada \_P.10 · 60 · 66



Le colonne **Opera** \_P.18  
The **Opera** columns \_P.18  
Les colonnes **Opera** \_P.18  
Die **Opera**-Säulen können \_P.18  
Las columnas **Opera** \_P.18



Specchio **Lumière**  
Barra accessoriata **Strike** laccata \_P.36  
Mirror **Lumière** and bar **Strike** lacquered \_P.36  
Miroir de la série **Lumière** et barre équipée **Strike** laquée \_P.36  
Spiegel **Lumière** und Bar **Strike** lackiert \_P.36  
Espejo de la serie **Lumière** y barra equipada **Strike** lacada \_P.36



Lavabo **Rock-Art** \_P.105  
Washbasin **Rock-Art** \_P.105  
Vasques **Rock-Art** \_P.105  
**Rock-Art** Waschbecken \_P.105  
Lavabos **Rock-Art** \_P.105



Specchio **Briks** \_P.71 · 78  
Mirror **Briks** \_P.71 · 78  
Miroir **Briks** \_P.71 · 78  
Spiegel **Briks** \_P.71 · 78  
Espejo **Briks** \_P.71 · 78



Lavabi **Afrodite** in Okite Nero Marquina 8069 \_P.98  
Washbasin **Afrodite** in Okite Nero Marquina 8069 \_P.98  
Vasques **Afrodite** en Okite Nero Marquina 8069 \_P.98  
**Afrodite** Waschbecken aus Okite Nero Marquina 8069 \_P.98  
Lavabos **Afrodite** en Okite Nero Marquina 8069 \_P.98



Lavabo **Zeus** con decoro **Mondrian** è realizzato in Okite Calacatta Oro 8052 \_P.68  
Washbasin **Zeus** with decoration **Mondrian** from Okite Calacatta Oro 8052 \_P.68  
Lavabo **Zeus** avec décoration **Mondrian** réalisé en Okite Calacatta Oro 8052 \_P.68  
Waschbecken **Zeus** mit Dekoration **Mondrian** von Okite Calacatta Oro 8052 \_P.68  
Lavabo **Zeus** con decoración **Mondrian** realizado en Okite Calacatta Oro 8052 \_P.68



Fianco di finitura con lavorazione **DOGATO** come i frontali \_P.53  
Side panel with **DOGATO** finishing as fronts \_P.53  
Côté de finition en **DOGATO** comme les façades \_P.53  
Abschlussseite aus **DOGATO** wie Fassaden \_P.53  
El costado final **DOGATO** como los frontales \_P.53



Frontali in **RIGATO** Juta opaco \_P.4 · 94  
Fianchetti in Gres \_P.8 · 90  
Fronts Juta **RIGATO** matt \_P.4 · 94  
Side panels in Gres \_P.8 · 90  
Façades en **RIGATO** Juta mat \_P.4 · 94  
Panneaux latéraux en Gres \_P.8 · 90  
Fronten Juta **RIGATO** matt \_P.4 · 94  
Seitentellen in Gres \_P.8 · 90  
Frontales en **RIGATO** Juta mate \_P.4 · 94  
Costados finales en Gres \_P.8 · 90

# Finiture

Finishes  
Finitions  
Oberflächen  
Acabados

## Laccato opaco/lucido

Matt/gloss lacquered / Laqué mat et brillant  
Matt oder glänzend lackiert / Lacado mate y brillo



\*SOLO OPACO / MATT ONLY / SEULEMENT MAT / NUR MATT / SOLO MATE

## Textures laccate nei colori opachi

Textures matt colours lacquered / Textures lacqués matt  
Textures matt lackierte / Textures lacqolos mate

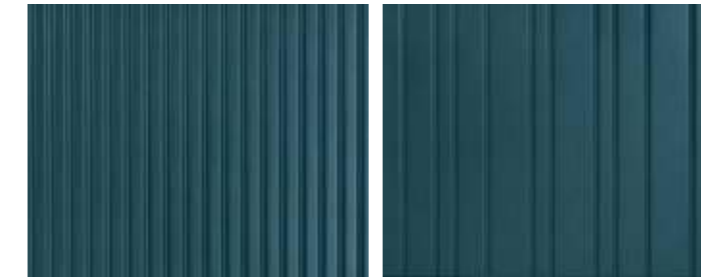

RIGATO

DOGATO

## Cannettato



## Bimelaminico Syncro

Bimelaminated Syncro / Bi-mé laminé Syncro  
Bimelamin Syncro / Bi-melamina Syncro

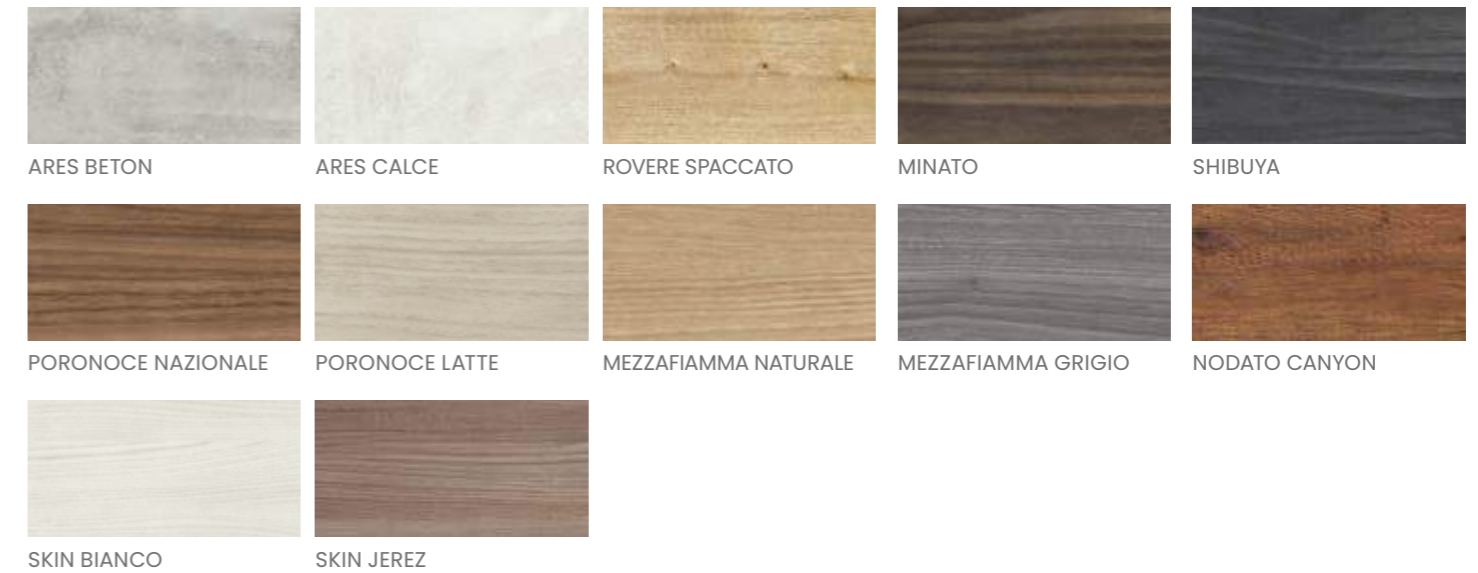

## Legni



ROVERE NORDICO  
NATURALE

ROVERE NORDICO  
CIOCCOLATO

ROVERE NORDICO  
CAFFÈ



NOCE CANALETTO

OLMO

EUCALIPTO  
AFFUMICATO

## Rovere fiammato decapé

Decapé Fiammato Oak / Chêne Fiammato Decapé

Decapé Fiammato Eiche / Roble Fiammato Decapé



BIANCO PORO SCURO

JUTA PORO BIANCO

CANAPA PORO BIANCO



FINESTRA PORO BIANCO

POLVERE PORO BIANCO

AVIO PORO BIANCO

## Rovere fiammato tinto

Fiammato Oak / Chêne Fiammato Teinté

Fiammato Eiche / Roble Fiammato



AGATA

CASTAGNA

CORDA



GRANO

QUARZO

TARTUFO

## Hpl unicolor



STATUARIO S. T. 439

CEMENTO 143

OLMO SCURO 303

OLMO BIONDO 134

ROVERE MONET 423



ROVERE TEXAS 306

ROVERE VERSAILLES 418

ROVERE CASTORO 301

SASSO 139

BASALTO 403



PORFIDO 119

OSSIDO 146

ARDESIA 145

MALTA BIANCA 430

MALTA GRIGIA 431

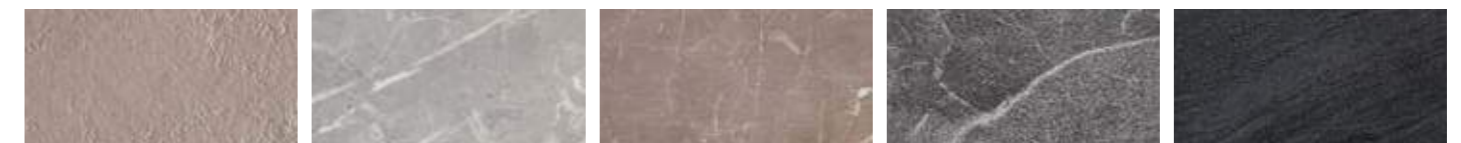

MALTA CANAPA 432

ANTIQUE

BOTTICINO 410

CUMA DARK 428

CALYPSO 435



TOBACCO 440

IMPERO 438

## Fenix



GRIGIO EFESO 725

VERDE COMODORO 750

BLU FES 754



BIANCO 32

NERO 720

BIBER 717

BROMO 724

GRIGIO 718

CATALOGUE PLANNIG  
**Maurizio Poletto**

R. & S.  
**Archeda Srl**

DESIGN E A.D.  
**Dario Poles**

GRAPHIC DESIGN CATALOGO  
**Graphosds**

FOTOGRAFIA  
**Gabriotti Fotografi**

FOTOLITO E STAMPA  
**graficheitalprint.it**

**MAGGIO 2024**

**Archeda, al fine di migliorare le caratteristiche tecniche e qualitative della sua produzione, si riserva di apportare, anche senza preavviso, tutte le modifiche che si rendessero necessarie.**

To improve the technical and the qualitative characteristics of the production, Archeda reserves the right to make all the suitable modifications without previous notice.

A fin daméliorer les caractéristiques techniques et qualitatives de sa production, la société Archeda se réserve le droit d'apporter, même sans preavis, toutes les modifications qui seront jugées nécessaires.

Um technische und qualitative Merkmale der Produktion zu verbessern, behält sich Archeda vor, alle nötige Abänderungen, ohne Avisierungen, vorzunehmen.

Archeda, a fin de mejorar las características técnicas y cualitativas de su producción, se reserva el derecho de aportar, incluso sin previo aviso, todas las modificaciones necesarias.





# GOLA

SISTEMA GOLA



# GOLA

SISTEMA GOLA

# GOLA

DESIGN DARIO POLES

PER LA COLLEZIONE GOLA, ARCHEDA SCEGLIE GLI ELEMENTI COMPONIBILI IN SCALA MINIMALE OVVERO IN ASSENZA DI MANIGLIA. L'APERTURA È FACILITATA DA UNA GOLA INTEGRATA CHE ATTRAVERSA L'INTERO LATO ORIZZONTALE DELL'ANTA. LA GAMMA DI FINITURE E ACCESSORI SI ARRICCHISCE DI NUOVI COLORI OPACHI E LUCIDI, DI NUOVI LAVABI, TOP ED ELEMENTI PERSONALIZZATI, COME LA BASE A GIORNO E IL PENSILE CON VASSOIO ED ANTA A RIBALTA. QUESTE SOLUZIONI COMPOSITIVE, FORTEMENTE CARATTERIZZANTI, PORTANO ELEGANZA E FUNZIONALITÀ NELLA ZONA BAGNO.

FOR THE GOLA COLLECTION, ARCHEDA HAS DECIDED TO PARE THE MODULAR UNITS RIGHT BACK, NAMELY REMOVING ALL HANDLES. A BUILT-IN FINGER CHANNEL RUNNING THE FULL WIDTH OF THE DOOR MAKES UNITS EASY TO OPEN. THE RANGE OF FINISHES AND ACCESSORIES HAS BEEN EXPANDED WITH THE ADDITION OF NEW MATT AND GLOSS COLOURS, NEW BASINS, TOPS AND CUSTOMIZED UNITS, LIKE THE OPEN BASE UNIT, AND WALL UNIT FEATURING A TRAY TOP AND DROP FLAP DOOR. THE COMBINATION OF THESE FEATURES RESULTS IN HIGHLY DISTINCTIVE SOLUTIONS, INTRODUCING ELEGANCE AND FUNCTION INTO THE BATHROOM.

POUR SA COLLECTION « GOLA » ARCHEDA A CHOISI DES ÉLÉMENTS COMPOSABLES EN VERSION MINIMALISTE, C'EST-À-DIRE SANS POIGNÉE. L'OUVERTURE EST FACILITÉE GRÂCE À LA GORGE INTÉGRÉE QUI COURT TOUT LE LONG DU CHANT HORIZONTAL DE LA PORTE. LA GAMME DES FINITIONS S'ENRICHIT DE NOUVEAUX COLORIS MATS ET BRILLANTS ALORS QUE CELLE DES ACCESSOIRES PROPOSE DE NOUVELLES VASQUES ET DE NOUVEAUX PLANS DE TOILETTE AINSI QUE DES ÉLÉMENTS PERSONNALISÉS COMME L'ÉLÉMENT BAS OUVERT ET L'ÉLÉMENT HAUT AVEC PLATEAU SUR LE DESSUS ET PORTE ABATTANTE. TOUTES CES SOLUTIONS HAUTEMENT DISTINCTIVES APPORTENT DE L'ÉLÉGANCE ET DE LA FONCTIONNALITÉ À LA SALLE DE BAINS.

FÜR DIE KOLLEKTION GOLA WÄHLT ARCHEDA ANBAUFÄHIGE ELEMENTE MIT MÖGLICHST GERINGEM UMFANG, D.H. OHNE GRIFFE. DIE ÖFFNUNG WIRD DURCH EINE INTEGRIERTE HOHLKEHLE ERLEICHTERT, DIE ÜBER DIE GESAMTE WAAGRECHTE INNENSEITE DER TÜR VERLÄUFT. DAS ANGEBOT AN AUSFÜHRUNGEN UND ZUBEHÖRTEILEN WIRD DURCH NEUE MATTE UND GLÄNZENDE FARBEN, NEUE WASCHBECKEN, WASCHTISCHPLATTEN UND MASSGESCHNEIDERTE ELEMENTE WIE DEN OFFENEN UNTERSCHRANK UND DEN HÄNGESCHRANK MIT ABLAGE UND Klapptür bereichert. DIESE SEHR INDIVIDUELLEN GESTALTUNGSLÖSUNGEN BRINGEN ELEGANZ UND FUNKTIONALITÄT IN DEN BADBEREICH

PARA LA COLECCIÓN GOLA, ARCHEDA ELIGE ELEMENTOS MODULARES EN ESCALA MINIMALISTA, ES DECIR, DESPROVISTOS DE TIRADOR. LA GOLA INTEGRADA QUE ATRAVIESA TODO EL LADO HORIZONTAL DE LA PUERTA FACILITA SU APERTURA. LA GAMA DE ACABADOS Y ACCESORIOS SE AMPLÍA CON NUEVOS COLORES MATES Y BRILLANTES Y CON NUEVOS LAVABOS, ENCIMERAS Y ELEMENTOS PERSONALIZADOS, COMO EL MUEBLE BAJO ABIERTO O EL COLGANTE CON BANDEJA Y PUERTA ABATIBLE. ALTAMENTE DISTINTIVAS, ESTAS SOLUCIONES COMPOSITIVAS APORTAN ELEGANCIA Y FUNCIONALIDAD AL CUARTO DE BAÑO.



# GOLA 01

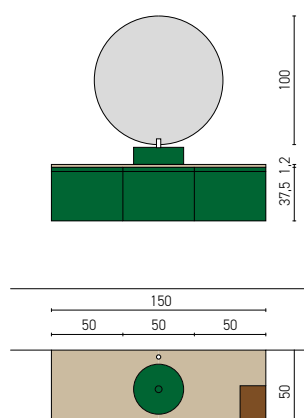

LACCATO VERDE VERONESE LUCIDO CON SCOCCA, VANO A GIORNO E PENSILI IN NODATO CANYON. TOP IN GRES SEMINATO CANDIDO CON LAVABO ROUND LUX VERDE VERONESE. SPECCHIO RAGGIO CON LED PERIMETRALI E LAMPADRE ROSSINI.

Verde Veronese glossy lacquered with Nodato Canyon structure, open compartment and wall elements. Seminato Candido gres top with Verde Veronese Round Lux basin. Raggio mirror with perimeter Leds and Rossini Lamps

Laquée Verde Veronese brillante avec structure, compartiment ouvert et éléments hauts en Nodato Canyon. P.d.T. en gres Seminato Candido avec vasque Round Lux Verde Veronese. Miroir Raggio avec LED périmétriques et lampes Rossini.

Verde Veronese glänzend lackiert mit Korpus, offenem Fach und Oberschränken Nodato Canyon. Waschtischplatte Gres Seminato Candido mit Becken mod. Round Lux Verde Veronese. Spiegel Raggio mit Perimeter-LED und Rossini-Lampen.

Lacado Verde Veronese brillo con cuerpo, compartimento abierto y muebles altos de Nodato Canyon. Encimera de gres Seminato Candido con lavabo Round Lux Verde Veronese. Espejo Raggio con LED perimetrales y lámparas Rossini.

















# GOLA 02

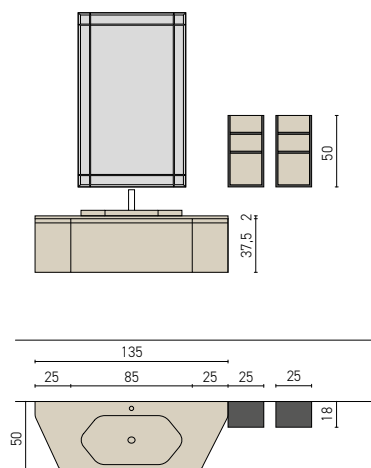

LACCATO JUTA OPACO, TOP OLYMPOS MIST CON LAVABO INCA IN GEACRYL COLOR MATT JUTA. SPECCHIO INCISO CON LAMPADA ROSSINI. ELEMENTI A GIORNO ICE IN VETRO FUMÉ GRIGIO CON RETRO JUTA.

Juta matt lacquered, Olympos Mist top with Juta Geacryl color matt Inca basin. Inciso mirror with Rossini lamp. Open elements Ice in grey smoked glass with Juta back.

Laquée Juta mate, P.d.T. en Olympos Mist avec vasque Inca en Geacryl color matt Juta. Miroir Inciso et lampe Rossini. Éléments ouvertes Ice en verre fumé gris avec dos Juta.

Juta matt lackiert, Waschtischplatte Olympos Mist mit Becken mod. Inca Geacryl color matt Juta. Spiegel mod. Inciso mit Rossini-Lampe. Ice offene Elemente aus grauem Rauchglas mit Juta-Rücken.

Juta matt lackiert, Waschtischplatte Olympos Mist mit Becken mod. Inca Geacryl color matt Juta. Spiegel mod. Inciso mit Rossini-Lampe. Ice offene Elemente aus grauem Rauchglas mit Juta-Rücken.













# GOLA 03

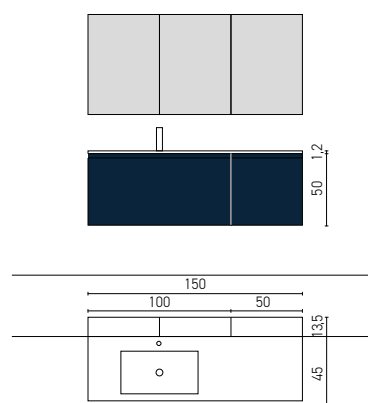

LACCATO OLTREMARE OPACO  
CON SCOCCA SHIBUYA. TOP  
TECNORIL CON VASCA AGG4.  
SPECCHI CONTENITORI CON  
LAMPADA STELLAR. ELEMENTI  
A GIORNO ICE IN VETRO FUMÉ  
GRIGIO CON RETRO SHIBUYA.

Oltremare matt lacquered with  
Shibuya structure. Tecnoril top with  
AGG4 integrated washbasin. Cabinet  
mirrors with Stellar lamp. Open  
elements Ice in grey smoked glass  
with Shibuya back.

Laquée Oltremare mate avec  
structure en Shibuya. P.d.T. en Tecnoril  
avec vasque intégrée AGG4. Armoires  
de toilette avec lampe Stellar.  
Éléments ouvertes Ice en verre fumé  
gris avec dos Shibuya.

Oltremare matt lackiert mit Korpus  
Shibuya. Waschtischplatte Tecnoril  
mit integriertem Becken AGG4.  
Spiegelschranken mit Stellar-Lampe.  
Ice offene Elemente aus grauem  
Rauchglas mit Shibuya-Rücken.

Lacado Oltremare mate con cuerpo  
Shibuya. Encimera de Tecnoril con  
cuba integrada AGG4. Armarios  
espejo con lámpara Stellar. Elementos  
abiertos Ice en cristal gris ahumado  
con trasera Shibuya.





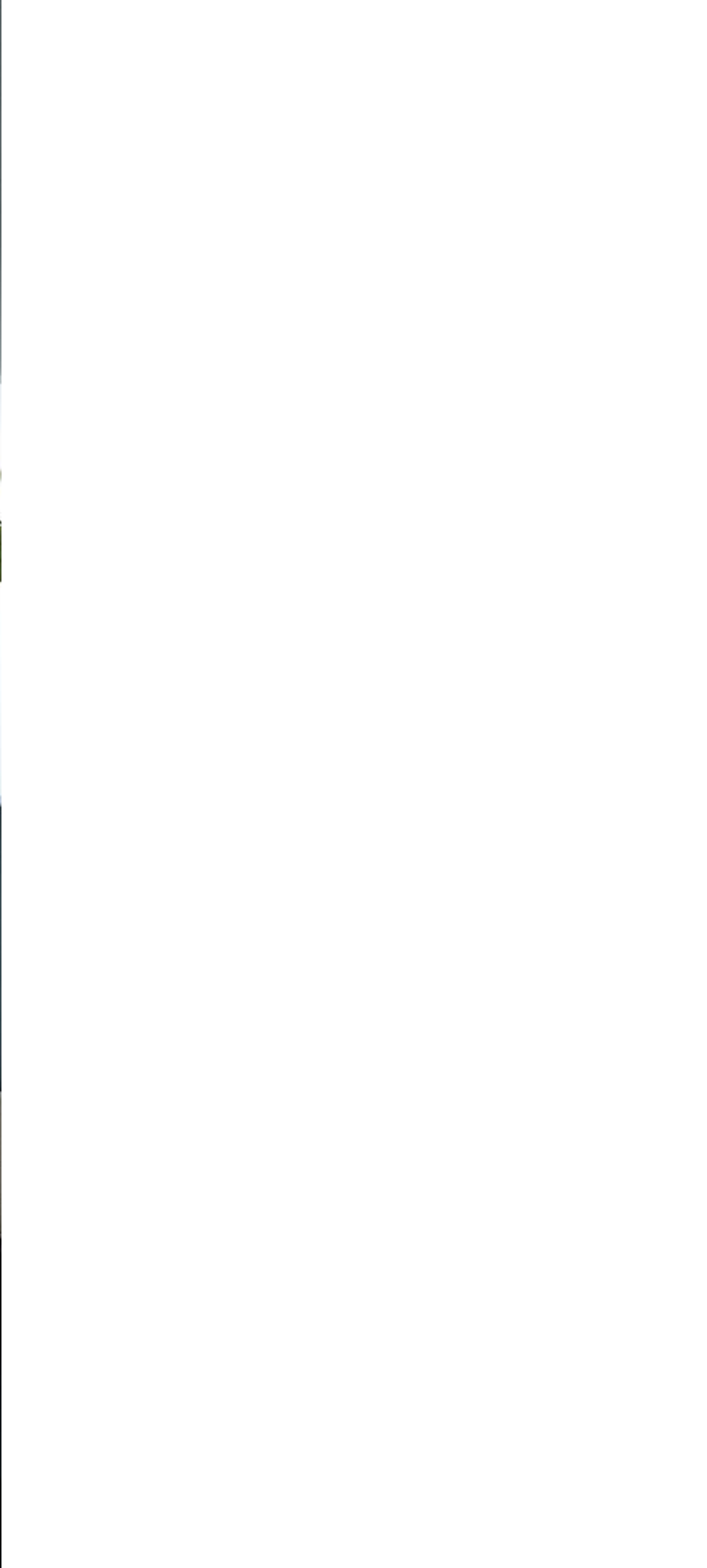











## GOLA 04

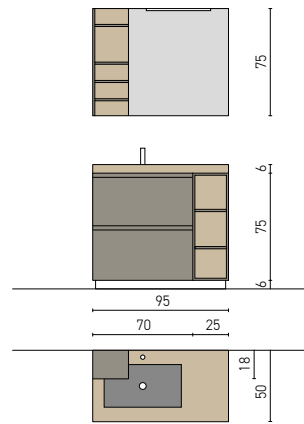

LACCATO KAKI OPACO, BASE A GIORNO E TOP IN HPL ROVERE TEXAS 306. VASCA INTEGRATA HF15 IN ACRILICO COLORE GRIGIO 718. SPECCHIO FILO CON LAMPADA METRO; ELEMENTO A GIORNO SQUARE.

Kaki matt lacquered, open base unit and top HPL Rovere Texas 306. HF15 integrated washbasin in Grigio 718 acrylic. Filo mirror with Metro lamp; Square open element.

Laquée Kaki mate, Élément bas ouvert et P.d.T en HPL Rovere Texas 306. Vasque intégrée HF15 en acrylique Grigio 718. Miroir Filo avec lampe Metro. Élément ouvert Square.

Kaki matt lackiert, offener Unterschrank und Waschtischplatte aus HPL Rovere Texas 306. Integrierte Becken HF15 aus Grigio 718 Acryl. Spiegel Filo mit Metro-Lampe; Square offenes Element.

Lacado Kaki mate, mueble bajo abierto y encimera en HPL Rovere Texas 306. Cuba integrada HF15 en acrílico Grigio 718. Espejo Filo con lámpara Metro; elemento abierto Square.

















# GOLA 05

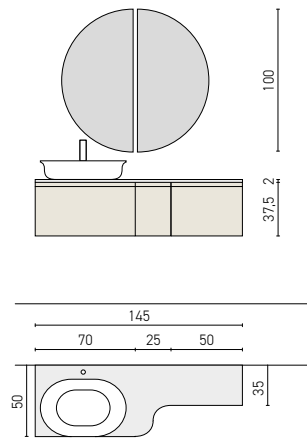

LACCATO BIANCO OPACO, TOP BIANCO CARRARA CON LAVABO NICOLE OVALE BIANCO. SPECCHI SPUTNIK CON LED PERIMETRALI E LAMPADINE TUBE NERE.

Bianco matt lacquered, Bianco Carrara marble top with white Nicole Ovale basin. Sputnik mirrors with perimeter Leds and black Tube lamps.

Laquée Bianco mate, P.d.T. en Bianco Carrara avec vasque Nicole Ovale blanche. Miroirs Sputnik avec LED périmétriques et lampes Tube noir.

Bianco matt lackiert, Waschtischplatte Bianco Carrara mit weißem Waschbecken Nicole Ovale. Spiegeln Sputnik mit Perimeter-LED und schwarze Tube-Lampe.

Lacado Bianco Mate, encimera Bianco Carrara con lavabo Nicole Ovale blanco. Espejos Sputnik con LED perimetrales y lámparas Tube negras.

















# GOLA 06

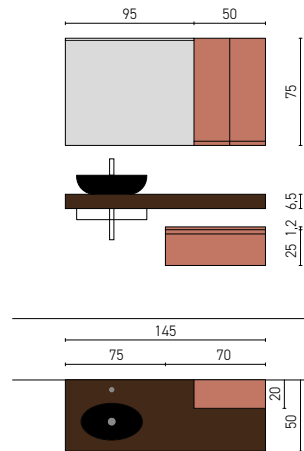

LACCATO MATTONE OPACO, TOP  
CORTECCIA VULCANIZZATO CON  
LAVABO SOFTLY NERO. SPECCHIO  
FILO CON LAMPADA METRO.

Mattone matt lacquered, Corteccia  
Vulcanizzato top with Black Softly  
basin. Filo mirror with Metro lamp.

Laquée Mattone mate, P.d.T. en  
Corteccia Vulcanizzato avec  
vasque Softly noir. Miroir Filo avec  
lampe Metro.

Mattone matt lackiert,  
Waschtischplatte Corteccia  
Vulcanizzato mit schwarzem Becken  
Softly. Spiegel Filo mit Metro-Lampe.

Lacado Mattone mate, encimera  
de Corteccia Vulcanizzato con  
lavabo Softly negro. Espejo Filo con  
lámpara Metro.





















# GOLA 07

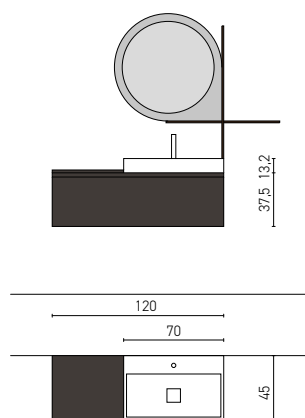

LACCATO TITANIO OPACO CON  
LAVABO FIGURA. SPECCHIO  
GOCCIA CON LAMPADA VERTIGO  
E MENSOLA PORTA- SALVIETTE.

Titanio matt lacquered with Figura  
basin. Goccia mirror with Vertigo  
lamps and towel-holder shelf.

Laquée Titanio mate avec vasque  
Figura. Miroir Goccia avec  
lampe Vertigo et étagère porte-  
serviettes.

Titanio matt lackiert mit Waschtisch  
Figura. Goccia Spiegel mit Vertigo-  
Lampe und Handtuchhalter.

Lacado Titanio mate con lavabo  
Figura. Espejo Goccia con lámpara  
Vertigo y toallero.

















# GOLA 08

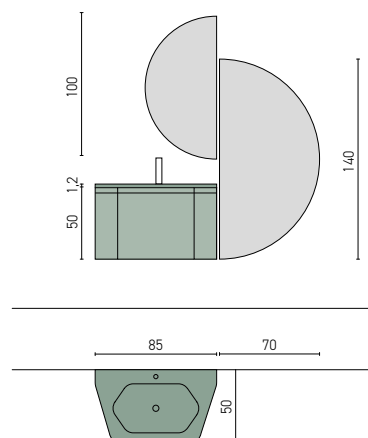

LACCATO FIENO OPACO, LAVABO MONOBLOCCO ANDE IN GEACRYL COLOR MATT GIADA. SPECCHI SPUTNIK CON LED PERIMETRALI E LAMPADIE TUBE BIANCHE. COMPOSIZIONE DI ELEMENTI A GIORNO SQUARE LACCATI FIENO OPACO CON PARTICOLARI ROVERE SPACCATO.

Fieno matt lacquered, Giada Geacryl color matt one-piece basin Ande. Sputnik mirrors with perimeter Leds and white Tube lamps. Composition of Square open elements in matt Fieno lacquer finish with Rovere Spaccato details.

Laquée Fieno mate, plan-vasque Ande en Geacryl color matt Giada. Miroirs Sputnik avec LED périmétriques et lampes Tube blanches. Composition d'éléments ouverts Square en finition laquée Fieno mate avec des détails en Rovere Spaccato.

Fieno matt lackiert, monobloc-Waschbecken Ande aus Geacryl color matt Giada. Spiegeln Sputnik mit Perimeter-LED und weißen Tube-Lampen. Zusammensetzung aus Square offenen Elementen in mattem Fieno-Lack mit Details aus Rovere Spaccato.

Lacado Fieno mate, lavabo monobloc Ande en Geacryl color matt Giada. Espejos Sputnik con LED perimetrales y lámparas Tube blancas. Composición de elementos abiertos Square en acabado lacado mate Fieno con detalles en Rovere Spaccato.

















# GOLA 09

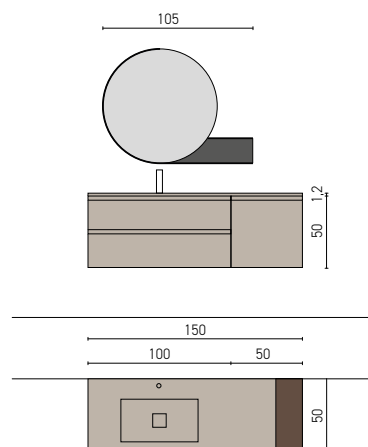

LACCATO CANAPA OPACO CON  
SCOCCHA E VANO A GIORNO  
MINATO. TOP IN GEACRYL COLOR  
MATT CANAPA CON VASCA LWW5.  
SPECCHIO VIRGOLA TITANIO CON  
LAMPADA ATLA.

Canapa matt lacquered with Minato  
structure and open compartment.  
Canapa Geacryl color matt top with  
LWW5 integrated washbasin. Titanio  
Virgola mirror with Atla lamp.

Laquée Canapa mate avec structure et  
compartiment ouvert en Minato. P.d.T.  
en Geacryl color matt Canapa avec  
vasque intégrée LWW5. Miroir Virgola  
Titanio avec lampe Atla.

Canapa matt lackiert mit Minato Korpus  
und offenem Fach. Waschtischplatte  
aus Geacryl Color Matt Canapa mit  
integriertem Waschbecken LWW5.  
Virgola Titanio Spiegel mit Atla-Lampe.

Lacado Canapa mate con cuerpo y  
compartimento abierto de Minato.  
Encimera de Geacryl color matt Canapa  
con cuba integrada LWW5. Espejo  
Virgola Titanio con lámpara Atla.





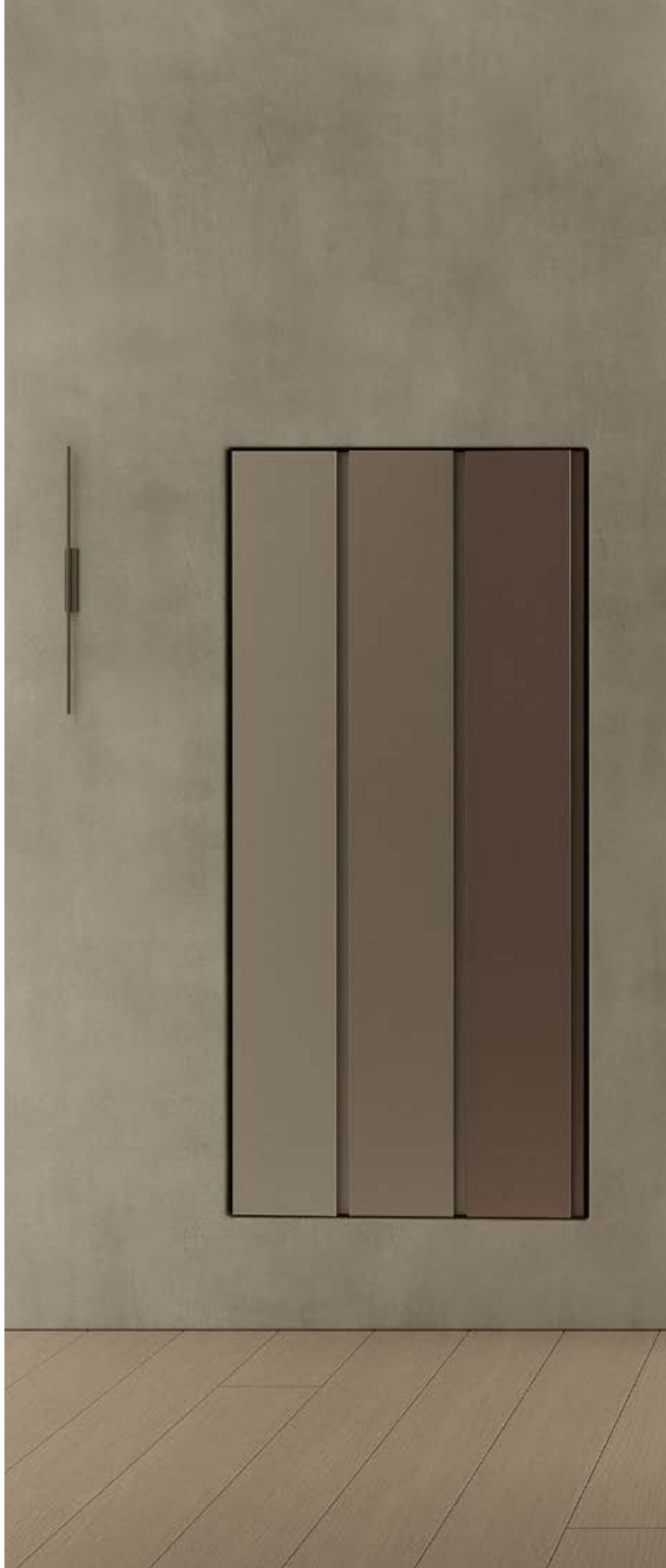

















# GOLA 10

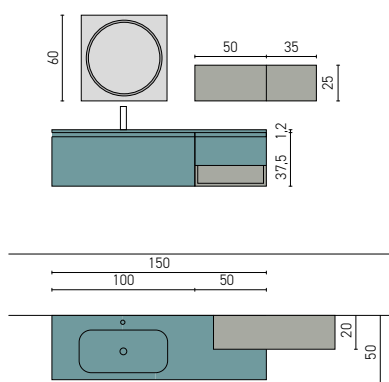

LACCATO ANICE OPACO CON  
SCOCCA E PENSILI FINESTRA  
OPACO. TOP IN VETRO ACIDATO  
ANICE CON VASCA VGG5.  
SPECCHIO LOOP.

Anice matt lacquered with Finestra matt structure and wall elements. Anice acid-etched glass top with VGG5 integrated basin. Loop mirror.

Laquée Anice mate avec structure et éléments hauts Finestra mate. P.d.T. en verre dépoli Anice avec vasque intégrée VGG5. Miroir Loop.

Anice matt lackiert mit Korpus und Oberschränken Finestra matt. Anice Milchglasplatte mit VGG5 integrierter Waschtischplatte. Spiegel Loop.

Lacado Anice mate con cuerpo y muebles altos Finestra mate. Encimera de cristal grabado al ácido Anice con cuba integrada VGG5. Espejo Loop.

















I PLUS  
**MODELLO GOLA**



## Pensile con coperchio ribassato

Wall unit with recessed top  
Élément haut avec dessus surbaissé  
Hängeschrank mit tieferliegender Abdeckung  
Colgante con tapa bajada

PENSILE CON COPERCHIO RIBASSATO CHE PERMETTE LA CREAZIONE DI UN PICCOLO VANO PER IL POSIZIONAMENTO DEGLI OGGETTI. L'ANTA A RIBALTA VERSO IL BASSO È LISCIA E SENZA MANIGLIA; CIO' RENDE L'ELEMENTO ABBINABILE TRASVERSALMENTE A QUALSIASI ALTRO MODELLO ARCHEDA. È DISPONIBILE NELLE LARGHEZZE DI 35 E 50 CM ALTO 25 E 37,5 CM.

Wall unit with recessed top, producing a small set-down space for bathroom paraphernalia. The bottom-hinged flap door is plain and handleless: this means the unit can be used in conjunction with all models across the Archeda range. It comes in a choice of widths (35 and 50 cm) and heights (25 and 37.5 cm).

Élément haut avec dessus surbaissé formant un plateau pour ranger des objets. La porte abattante est lisse et sans poignée : cela permet à cet élément d'être transversal et de pouvoir s'associer à n'importe quel autre modèle Archeda. Il existe dans les largeurs 35 et 50 cm et dans les hauteurs 25 et 37,5 cm.

Der Hängeschrank mit tieferliegender Abdeckung erlaubt die Schaffung eines kleinen Fachs zur Unterbringung von Gegenständen. Die Klapptür nach unten ist glatt und grifflos, wodurch sich das Element raumübergreifend mit jedem anderen Modell Archeda kombinieren lässt. Das Element ist in den Breiten 35 und 50 cm mit Höhe 25 und 37,5 cm erhältlich.

Colgante con tapa bajada, que permite crear un pequeño compartimento para colocar objetos. La puerta abatible hacia abajo es lisa y está desprovista de tirador: esto permite combinar el elemento transversalmente con cualquier otro modelo Archeda. Está disponible en las anchuras de 35 y 50 cm, con una altura de 25 y 37,5 cm.



## Base terminale h 37,5 e 50 cm

End base unit H 37.5 and 50 cm

Terminal bas h. 37,5 et 50 cm

Abschluss-Unterschrank H. 37,5 und 50 cm

Mueble bajo terminal h 37,5 y 50 cm

ELEMENTO LARGO 50 CM CON CASSETTO E VANO A GIORNO TERMINALE SINISTRO O DESTRO. LA STRUTTURA È COMPOSTA DA UN VANO PER CASSETTO LARGO 35 E PARTE TERMINALE A GIORNO LARGA 15 CM ; IL TUTTO VIENE CHIUSO DAL FRONTALE COMPOSTO DA 2 ELEMENTI UNITI A 45° A FORMARE UNA "L" CHE COPRE TOTALMENTE LA PARTE FRONTALE DELLA BASE E SOLO PARZIALMENTE LA PARTE LATERALE, LASCIANDO LIBERA UNA PORZIONE DEL VANO A GIORNO. A SECONDA DI COME VIENE PREVISTO IL TOP DI FINITURA DELLA COMPOSIZIONE, L'ACCESSO ALLA PARTE A GIORNO PUÒ AVVENIRE IN 3 MODALITÀ:

1. ACCESSO LATERALE E DALL'ALTO PARZIALE
2. ACCESSO LATERALE E DALL'ALTO TOTALE
3. ACCESSO SOLO LATERALE

50cm wide unit with drawer and open end section on the left or right. The structure comprises a compartment accommodating a 35cm-wide drawer and a 15cm-wide open end section; the resulting unit is closed behind a front made up of 2 elements meeting at 45° to form an L shape, covering the front of the base unit completely, while the side section is concealed only partially, leaving part of the open shelving exposed.

Depending on the type of top chosen to finish off the configuration, the open section can be accessed in one of 3 ways:

- 1 access from the side and partial access from above
- 2 access from the side and full access from above
- 3 access from the side only

Élément terminal, gauche ou droit, de 50 cm de large avec tiroir et niche. La structure se compose d'un compartiment pour tiroir de 35 cm de large et d'une partie terminale ouverte de 15 cm de large. L'ensemble est fermé par une façade se composant de 2 vantaux unis à 45° afin de former un « L » et couvrant totalement l'avant de l'élément bas et partiellement son côté, en laissant ainsi une partie du compartiment ouverte. Selon la forme choisie pour le plan de toilette, l'accès à la partie ouverte peut s'effectuer de 3 différentes façons :

- 1 accès latéral et, depuis le haut, accès partiel
- 2 accès latéral et, depuis le haut, accès total
- 3 accès uniquement latéral

Element Breite 50 cm mit Schublade und offenem Abschlussabteil links oder rechts. Die Struktur besteht aus einem Schubladenabteil Breite 35 und einem offenem Abschlussabteil Breite 15 cm. Die Einheit wird durch eine Front verschlossen, die aus 2 in einem Winkel von 45° miteinander verbundenen Elementen besteht, die ein „L“ bilden, das den vorderen Teil des Unterschanks vollständig und den Seitenteil nur teilweise verdeckt, wodurch ein Teil des offenen Abteils sichtbar bleibt. Je nachdem, wie die Abschluss-Abdeckplatte der Zusammenstellung gestaltet ist, kann der Zugriff zum offenen Teil auf 3 Arten erfolgen:

- 1 seitlicher und oberer teilweiser Zugriff
- 2 seitlicher und oberer voller Zugriff
- 3 nur seitlicher Zugriff

Elemento de 50 cm de anchura con cajón y compartimento abierto terminal izquierdo o derecho. La estructura está compuesta por un compartimento para cajón de 35 cm de anchura y una parte terminal abierta de 15 cm, y el conjunto se cierra con un frente compuesto por 2 elementos unidos formando una «L» de 45° que cubre totalmente la parte frontal del mueble bajo y parcialmente la lateral, dejando libre una parte del compartimento abierto. Dependiendo de la encimera de acabado incluida en la composición, el acceso a la parte abierta puede tener lugar de 3 modos:

- 1 acceso lateral y desde arriba parcial
- 2 acceso lateral y desde arriba total
- 3 acceso solo lateral

## Base terminale h 37,5 e 50 cm

End base unit H 37.5 and 50 cm

Terminal bas h. 37,5 et 50 cm

Abschluss-Unterschrank H. 37,5 und 50 cm

Mueble bajo terminal h 37,5 y 50 cm



## Finiture

Finishes  
Finitions  
Ausführungen  
Acabados

### Laccato opaco/lucido

Matt/gloss lacquered / Laqué mat et brillant  
Matt oder glänzend lackiert / Lacado mate y brillo



## Terre



\*Solo opaco  
Matt only /  
Seulement mat  
Nur matt /  
Solo mate

# GOLA

DESIGN DARIO POLES

CARATTERISTICA DI QUESTO MODELLO È L' APERTURA A "GOLA" INTEGRATA NELL' ANTA CHE DONA A AL PROGRAMMA UNA FORTE PULIZIA FORMALE. L'ASSENZA DI MANIGLIE DEFINISCE LO SPIRITO MINIMALISTA DI GOLA GARANTENDOGLI UNA PRESENZA DISCRETA ED ELEGANTE. È DISPONIBILE IN 47 COLORI OPACHI E LUCIDI E IN 5 FINITURE DI ECO-MALTA TERRE E COMPRENDE UNA SERIE DI ELEMENTI SPECIALI COME I TERMINALI SFACCETTATI E I NUOVI VANI A GIORNO PROPOSTI IN DIVERSE CONFIGURAZIONI CHE LO RENDONO SARTORIALE ED UNICO.

A DISTINCTIVE FEATURE ON THIS MODEL IS THE FINGER CHANNEL BUILT INTO THE DOOR, WHICH GIVES THE SYSTEM A VERY SLEEK LOOK. THE ABSENCE OF HANDLES DETERMINES GOLA'S MINIMALIST FEEL, ENSURING IT MAKES A RESTRAINED, ELEGANT STATEMENT. IT COMES IN 47 MATT AND GLOSS COLOURS AND IN 5 ECO-MALTA TERRE FINISHES, AND INCLUDES A SERIES OF SPECIAL UNITS – LIKE THE FACETED END UNITS AND NEW OPEN SHELVING UNITS IN A RANGE OF DIFFERENT CONFIGURATIONS – MAKING IT A UNIQUE, BESPOKE OPTION.

LA CARACTÉRISTIQUE DE CE MODÈLE EST L'OUVERTURE AVEC GORGE INTÉGRÉE À LA PORTE, QUI DONNE AU PROGRAMME UNE NETTÉTÉ FORMELLE MARQUÉE. L'ABSENCE DE POIGNÉES DÉTERMINE L'ESPRIT MINIMALISTE DU MODÈLE « GOLA » EN LUI ASSURANT UN ASPECT DISCRET ET ÉLÉGANT. IL EXISTE EN 47 COLORIS MATS ET BRILLANTS AU CHOIX ET EN 5 FINITIONS ECO-MALTA TERRE. IL PROPOSE ÉGALEMENT UNE SÉRIE D'ÉLÉMENTS PARTICULIERS COMME LES TERMINAUX GALBÉS ET LES NOUVEAUX ÉLÉMENTS OUVERTS DÉCLINÉS EN DIFFÉRENTES VERSIONS, CE QUI DONNE UN ESPRIT ARTISANAL ET UNIQUE À CE MODÈLE.

HERVORSTECHENDES MERKMAL DIESES MODELLS IST DIE ÖFFNUNG MIT IN DIE TÜR INTEGRIERTER „HOHLKEHLE“, DIE DEM PROGRAMM EINE STARKE FORMALE REINHEIT SCHENKT. DAS FEHLEN VON GRIFFEN UNTERSTREICHT DEN MINIMALISTISCHEN ANSATZ VON GOLA UND SCHENKT IHM EINE ZURÜCKHALTENDE UND ELEGANTE PRÄSENZ. DAS MODELL IST IN 47 MATTEN UND GLÄNZENDEN FARBEN UND IN 5 AUSFÜHRUNGEN ÖKOZEMENT TERRE ERHÄLTlich UND UMFASST EINE REIHE VON SPEZIALELEMENTEN WIE ABGESCHRÄGTE ABSCHLUSSMODULE UND NEUE OFFENE ABTEILE, DIE IN VERSCHIEDENEN KONFIGURATIONEN ANGEBOten WERDEN UND IHM EINE INDIVIDUELLE UND EINZIGARTIGE NOTE VERLEIHEN.

LA CARACTERÍSTICA DISTINTIVA DE ESTE MODELO ES LA APERTURA CON «GOLA» INTEGRADA EN LA PUERTA, QUE APORTA UNA FUERTE LIMPIEZA FORMAL. LA AUSENCIA DE TIRADORES Y EL ESPÍRITU MINIMALISTA DEL SISTEMA GOLA GARANTIZAN UNA PRESENCIA DISCRETA Y ELEGANTE. ESTÁ DISPONIBLE EN 47 COLORES MATES Y BRILLANTES Y EN 5 ACABADOS DE MORTERO ECOLÓGICO EFECTO TIERRA E INCLUYE UNA SERIE DE ELEMENTOS ESPECIALES, COMO LOS TERMINALES FACETADOS O LOS NUEVOS COMPARTIMENTOS ABIERTOS PROPUESTOS EN DISTINTAS CONFIGURACIONES, QUE LE IMPRIMEN UN CARÁCTER ÚNICO Y SARTORIAL.

CATALOGUE PLANNIG

**Maurizio Poletto**

DESIGN E A.D.

**Dario Poles**

GRAPHIC DESIGN CATALOGO

**Graphosds**

FOTOGRAFIA

**Gabriotti Fotografi**

FOTOLITO E STAMPA

**graficheitalprint.it**

**MARZO 2023**

**Archeda, al fine di migliorare le caratteristiche tecniche e qualitative della sua produzione, si riserva di apportare, anche senza preavviso, tutte le modifiche che si rendessero necessarie.**

To improve the technical and the qualitative characteristics of the production, Archeda reserves the right to make all the suitable modifications without previous notice.

Afin d'améliorer les caractéristiques techniques et la qualité de sa production, la société Archeda se réserve le droit d'apporter, même sans préavis, toutes les modifications qu'elle jugera nécessaires.

Um technische und qualitative Merkmale der Produktion zu verbessern, behält sich Archeda vor, alle nötige Abänderungen, ohne Avisierungen, vorzunehmen.

Archeda, a fin de mejorar las características técnicas y cualitativas de su producción, se reserva el derecho de aportar, incluso sin previo aviso, todas las modificaciones necesarias.







# LINEA

SISTEMA GOLA

**LINEA**

SISTEMA GOLA



# LINEA

**LINEA SI UNISCE AI MODELLI TULLE E GOLA A COMPLETAMENTO DEL SISTEMA. LA MANIGLIA PROFILO IN ALLUMINIO IN FINITURA TITANIO, ALLUMINIO SATINATO, BIANCO E LACCATA NEI COLORI OPACHI, SI PUÒ APPLICARE ALL'INTERA GAMMA DI DECORATIVI, LEGNI E COLORI LACCATI DELLA PRODUZIONE ARCHEDA, CREANDO COSÌ MOLTEPLICI COMBINAZIONI CROMATICHE TRA FRONTALI, GOLE E ACCESSORI E MANTENENDO UNA RIGOROSA PULIZIA ESTETICA**

LINEA JOINS THE TULLE AND GOLA MODELS TO COMPLETE THE COLLECTION. THE ALUMINIUM PROFILE HANDLE IN TITANIUM, SATIN ALUMINIUM, MATT WHITE AND LACQUERED IN MATT COLORS CAN BE APPLIED TO THE FULL RANGE OF DECORATIVE, WOOD AND LACQUERED COLOUR FINISHES MADE BY ARCHEDA. THIS CREATES A VAST RANGE OF POSSIBLE COLOUR COMBINATIONS FOR FRONT PANELS, GROOVES AND ACCESSORIES, WHILE KEEPING THE OVERALL LOOK CLEAN AND SLEEK.

LINEA S'UNIT AUX MODÈLES TULLE ET GOLA AFIN DE COMPLÉTER LE SYSTÈME. LA POIGNÉE AVEC PROFIL EN ALUMINIUM EN FINITION TITANIO, SATIN ALUMINIUM, BLANC MAT ET LAQUÉE DANS LES COULEURS MATES PEUT ÊTRE APPLIQUÉE SUR TOUTE LA GAMME DE DÉCORATIONS, BOIS ET COLORIS LAQUÉS DE LA PRODUCTION ARCHEDA, EN CRÉANT AINSI DE MULTIPLES COMBINAISONS CHROMATIQUES ENTRE FAÇADES, GORGES ET ACCESSOIRES ET TOUT EN MAINTENANT UNE RIGOREUSE NETTÉTÉ ESTHÉTIQUE.

LINEA IST EINE ERGÄNZUNG ZU DEN MODELLEN TULLE UND GOLA UND VERVOLLSTÄNDIGT UNSER EINRICHTUNGSSYSTEM. DER ALUMINIUM-PROFILGRIF F IST IN DEN AUSFÜHRUNGEN TITANIO, SATINIERTEM ALUMINIUM, MATTWEISS UND IN DEN MATTEN FARBEN LACKIERT KANN MIT DER GESAMTEN PALETTE DER VON ARCHEDA HERGESTELLTEN DEKOREN, HÖLZERN UND LACKIERTEN FARBEN KOMBINIERT WERDEN. ES ENTSTEHT EIN VIELFÄLTIGES FARBliches ZUSAMMENSPiEL ZWISCHEN FRONTEN, KEHLEISTEN UND ZUBEHÖR, DAS DEM RAUM EINE LINEARE ÄSTHETIK GIBT.

LINEA SE UNE A LOS MODELOS TULLE Y GOLA PARA COMPLETAR EL SISTEMA. EL TIRADOR DE PERFIL DE ALUMINIO EN ACABADO TITANIO, ALUMINIO SATINADO, BLANCO MATE Y LACADO EN LOS COLORES MATE ES COMPATIBLE CON TODA LA GAMA DE DECORACIONES, MADERAS Y COLORES LACADOS DE ARCHEDA, CREANDO ASÍ MÚLTIPLES COMBINACIONES CROMÁTICAS ENTRE FRENTES, GOLAS Y ACCESORIOS Y MANTENIENDO UNA ESTRICTA LIMPIEZA ESTÉTICA.

## COMPOSIZIONE L01

**Nodato Canyon con particolari laccati Titanio e maniglia Titanio, top Gres Noir Desir opaco sp. 6 cm con vasca integrata "GGG5", specchio Filo con lampada Metro**

Nodato Canyon with Titanio lacquered details and Titanio handle. Th.6 cm Gres Noir Desir matt top with "GGG5" integrated basin, Filo mirror with Metro lamp

Nodato Canyon avec détails et poignée Titanio. Plan de toilette ép. 6 cm en gres Noir Desir mat avec vasque intégrée "GGG5". Miroir Filo avec lampe Metro

Nodato Canyon mit Details und Griffe Titanio,Waschtischplatte Gres Noir Desir matt St. 6 cm mit integriertem Becken "GGG5".Spiegel mod.Filo und Lampe mod.Metro

Nodato Canyon con detalles y tirador Titanio. Encimera de gres Noir Desir mate Esp. 6 cm con cuba integrada "GGG5", espejo Filo y lampara Metro

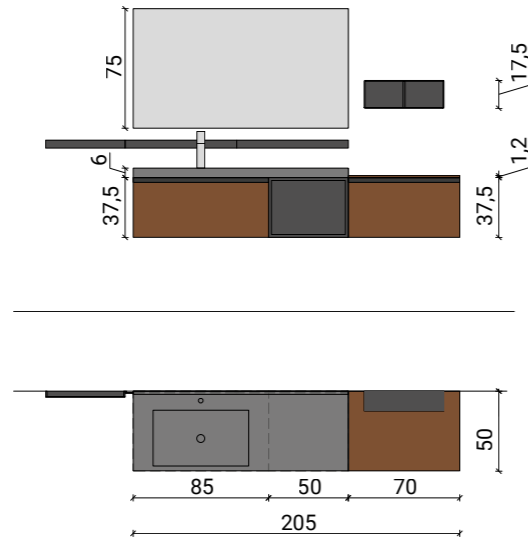

BIMELAMINICO SYNCRO  
NODATO CANYON



LACCATO  
TITANIO OPACO

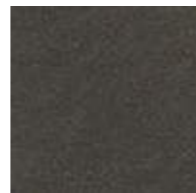

GRES  
NOIR DESIR OPACO

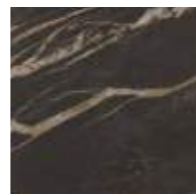



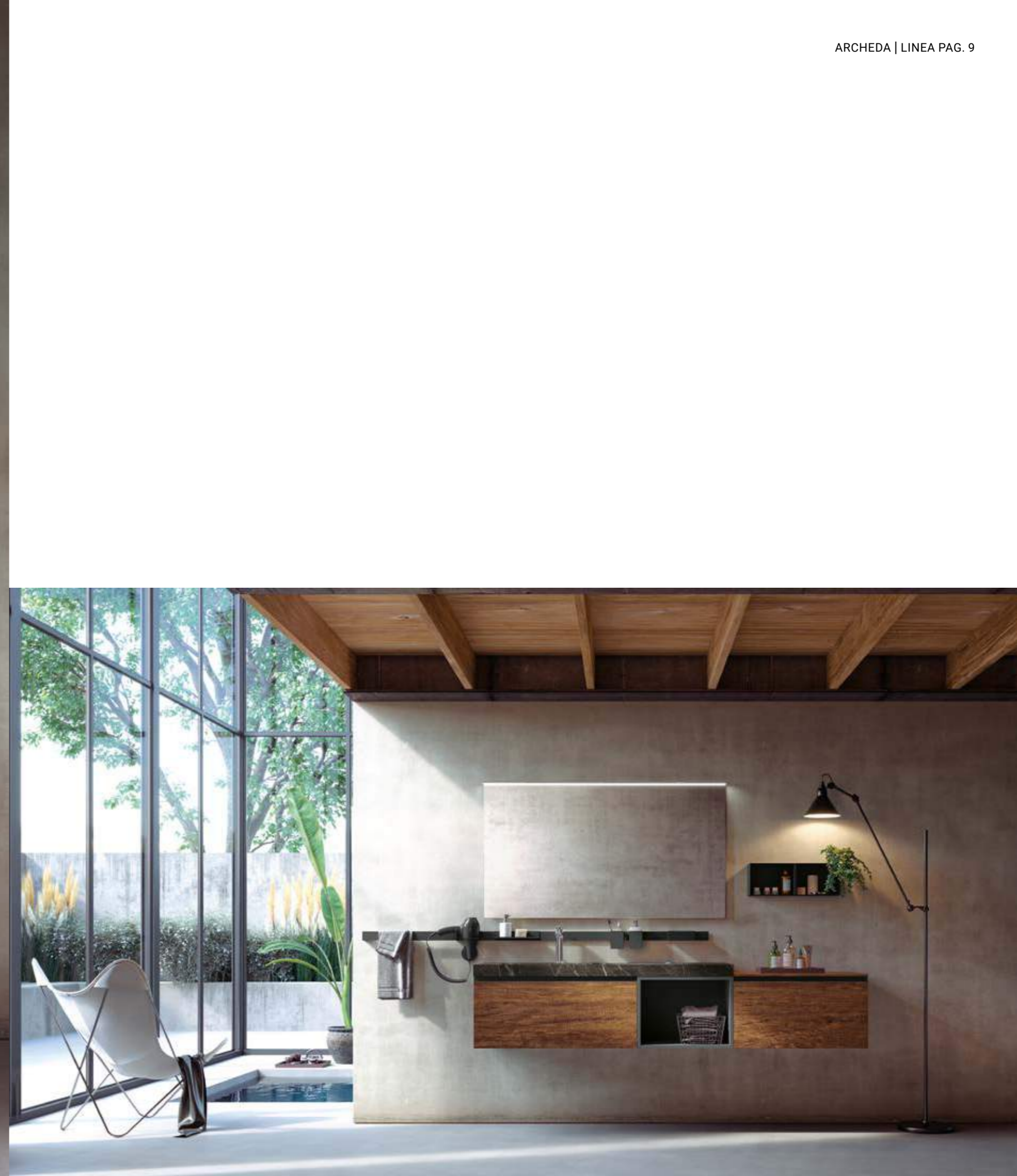





## COMPOSIZIONE L02

Hpl Antique, maniglia Alluminio satinato, pensile ed elementi a giorno "Square" laccati bianco opaco. Top Hpl Antique sp. 10 cm con vasca integrata "HFF5", specchio Moon

Hpl Antique, Aluminium matt handle, lacquered Bianco matt wall unit and "Square" open elements. Th. 10 cm Hpl Antique top with "HFF5" integrated basin, Moon mirror

Hpl Antique, poignée aluminium, Élément haut et éléments ouverts "Square" Bianco mat. Plan de toilette en Hpl Antique ép.10 cm avec vasque intégrée "HFF5", miroir Moon

Hpl Antique mit Griffe Aluminium Satiniert.Wandhängeschrank und offene Elementen "Square" lackiert Bianco Matt.Waschtischplatte Hpl Antique St.10 cm mit integriertem Becken "HFF5", Spiegel mod. Moon

Hpl Antique con tirador aluminio, colgante y módulos abiertos "Square" Bianco mate. Encimera de Hpl Antique Esp. 10 cm con cuba integrada "HFF5", espejo Moon

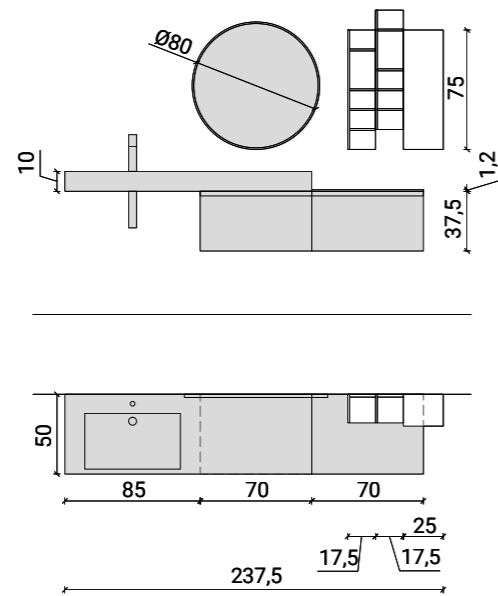





## COMPOSIZIONE L03

**Hpl Tobacco 440 con particolari e maniglia Titanio. Top Hpl Tobacco 440 sp. 6 cm con vasca integrata "HHH5", specchio Modular**

Hpl Tobacco 440 with Titanio details and handle. Th. 6 Hpl Tobacco 440 top with "HHH5" integrated basin, Modular mirror

Hpl Tobacco 440 avec détails et poignée Titanio. Plan de toilette en Hpl Tobacco 440 ép. 6 cm avec vasque intégrée "HHH5", miroir Modular

Hpl Tobacco 440 mit Details und Griffe Titanio. Waschtischplatte Hpl Tobacco 440 St. 10 cm mit integriertem Becken "HHH5", Spiegel mod. Modular

Hpl Tobacco 440 con detalles y tirador Titanio. Encimera de Hpl Tobacco 440 Esp. 10 cm con cuba integrada "HHH5", espejo Modular

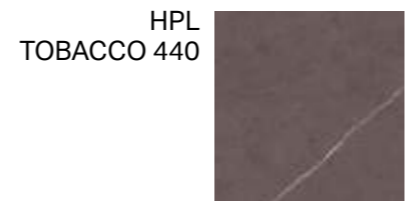
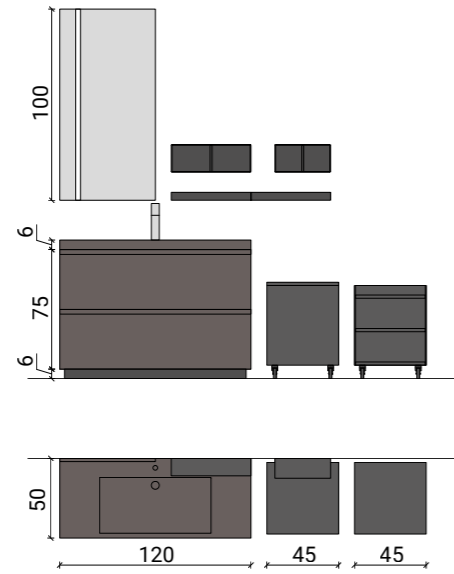







## COMPOSIZIONE L04

**Skin Bianco con maniglia Titanio.  
Top Hpl Calypso 435 sp. 10 cm  
con vasca integrata "HFF5",  
specchio Filo con lampada Metro**

Skin Bianco with Titanio handle. Th. 10  
cm Hpl Calypso 435 top with "HFF5"  
integrated basin, Filo mirror with

Skin Bianco avec poignée Titanio. Plan  
de toilette en Hpl Calypso 435 ép. 10  
cm avec vasque intégrée "HFF5", miroir  
Filo avec lampe Metro

Skin Bianco mit Griffe Titanio.  
Waschtischplatte Hpl Calypso 435 St.  
10 cm mit integriertem Becken "HFF5".  
Spiegel mod.Filo und Lampe mod.Metro

Skin Bianco con tirator Titanio. Encimera  
de Hpl Calypso 435 Esp. 10 cm con  
cuba integrada "HFF5", espejo Filo con  
lampara Metro

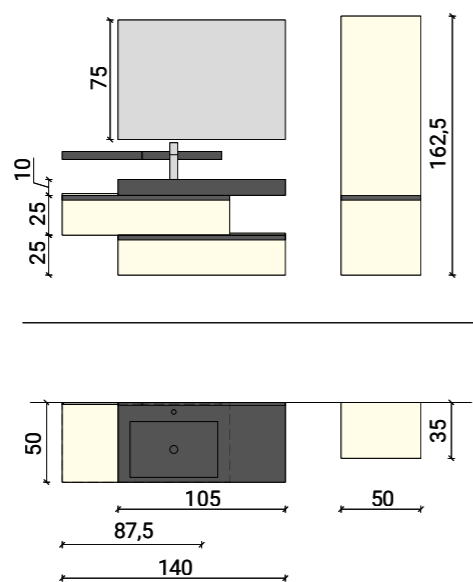

SKIN  
BIANCO



HPL  
CALIPSO 435

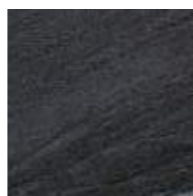









## COMPOSIZIONE L05

**Mattone opaco e Terre Roma con particolari e maniglia Titanio. Top Terre Roma sp. 6 cm con vasca integrata TGG5, specchio Gamma e lampade Tube in metallo nero.**

Mattone matt lacquered and Terre Roma with Titanio details and handle. Th. 6 cm Terre Roma top with TGG5 integrated washbasin. Black metal Gamma mirror and Tube lamps.

Mattone mat et Terre Roma avec détails et poignée Titanio. Plan de toilette ép. 6 cm en Terre Roma avec vasque intégrée TGG5. Miroir Gamma et lampe Tube en métal noir.

Mattone matt und Terre Roma mit Details und Griffe Titanio. Waschtischplatte Terre Roma St. 6 cm mit integriertem Becken TGG5. Spiegel mod. Gamma und Lampe mod. Tube in Schwartz Metall.

Mattone mate y Terre Roma con detalles y tirador Titanio. Encimera ep. 6 cm con cuba integrada TGG5 de Terre Roma, espejo Gamma y lampara Tube

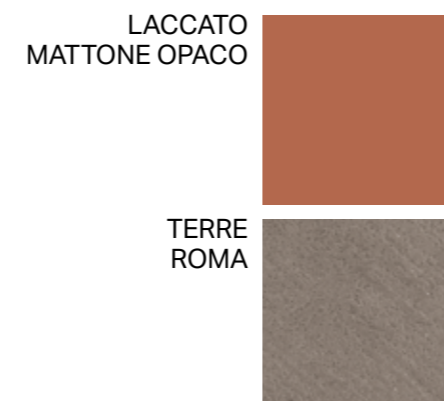
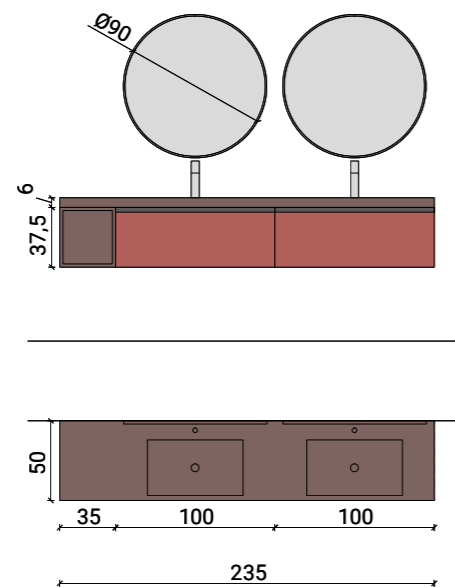







## COMPOSIZIONE L06

**Skin Jerez, elementi a giorno**  
**Square laccati Bianco opaco,**  
**maniglia Alluminio satinato. Top**  
**Tecnoril con vasca integrata**  
**"AHH5", specchio Filo con**  
**lampada Clio Slim**

Skin Jerez, Bianco matt "Square" open  
 elements, aluminium matt handle.  
 Tecnoril top with "AHH5" integrated  
 basin, Filo mirror with Clio Slim lamp

Skin Jerez, éléments ouverts "Square"  
 Bianco mat, poignée aluminium. Plan  
 de toilette en Tecnoril avec vasque  
 intégrée "AHH5", miroir Filo avec lampe  
 Clio Slim

Skin Jerez, Offenes Element "Square"  
 lackiert Bianco matt, Griffe Aluminium  
 Satiniert. Waschtischplatte Tecnoril mit  
 integriertem Becken "AHH5", Spiegel  
 mod. Filo und Lampe mod. Clio Slim

Skin Jerez con módulos abiertos  
 "Square" Bianco mate, tirador aluminio.  
 Encimera de Tecnoril con cuba  
 integrada "AHH5", espejo Filo y lampara  
 Clio Slim

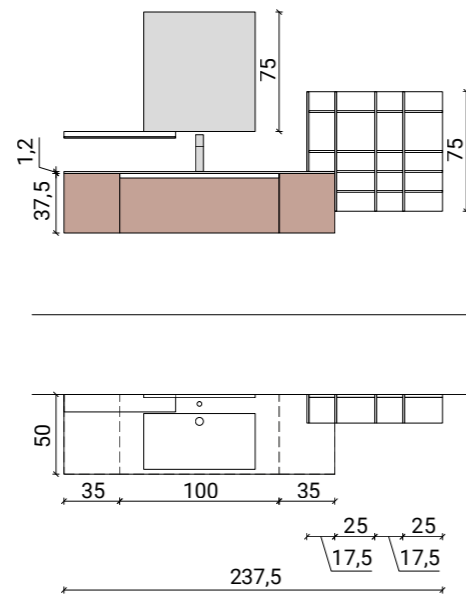

SKIN  
JEREZ

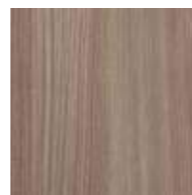

LACCATO  
BIANCO OPACO











## COMPOSIZIONE L07

**Impiallacciato Olmo con particolari Hpl Tobacco 440 e maniglia Titanio. Top Hpl Tobacco 440 con vasca integrata "HHh5", specchio Gamma e lampade Tube in metallo nero**

Olmo veneered with Hpl Tobacco 440 details and Titanio handle. Hpl Tobacco 440 top with "HHh5" integrated basin, black metal Gamma mirror and Tube lamps

Placage bois Olmo avec détails en Hpl Tobacco 440 et poignée Titanio. Plan de toilette en Hpl Tobacco 440 avec vasque intégrée "HHh5", miroir Gamma avec lampe Tube en métal noir

Olmo furniert mit Details Hpl Tobacco 440 und Griffe Titanio. Waschtischplatte Hpl Tobacco 440 mit integriertem "HHh5" Becken. Spiegel mod. Gamma und Lampe mod. Tube in Metall Schwartz

Chapa de Olmo con detalles de Hpl Tobacco 440 y tirador Titanio. Encimera de Hpl Tobacco 440 con cuba integrada "HHh5", espejo Gamma y lamparas Tube de metal negro mate

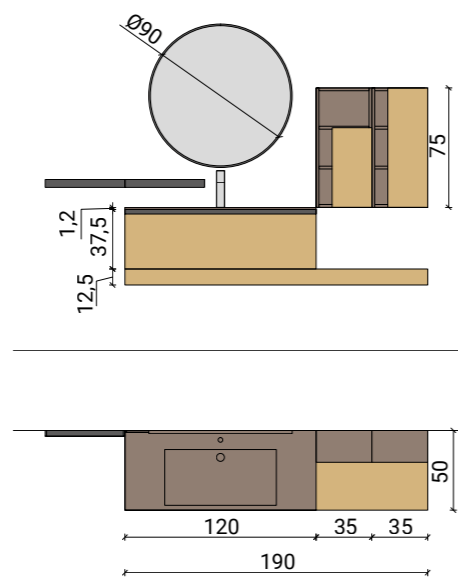

IMPIALLACCIATO  
OLMO



HPL  
TOBACCO 440

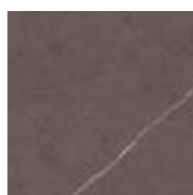







# COMPOSIZIONE L08

**Impiallacciato Rovere Fiammato Castagna con maniglia Titanio. Lavabo Figura, specchio Modular.**

Castagna Fiammato Oak veneered with Titanio handle. Figura washbasin and Modular mirror.

Placage Chêne Fiammato Castagna avec poignée Titanio. Lavabo Figura et miroir Modular.

Fiammato Castagna Eiche furniert mit Griffe Titanio. Figura Waschbecken und Spiegel mod. Modular.

Chapa de roble Fiammato Castagna con tirador Titanio. Cuba Figura y espejo Modular.

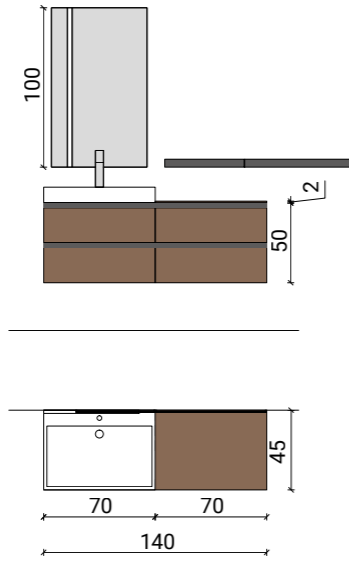

IMPIALLACCIATO  
ROVERE FIAMMATO CASTAGNA











ACCESSORI & FINITURE  
**MODELLO LINEA**



ACCESSORI STRIKE



BARRA



PORTASALVIETTE

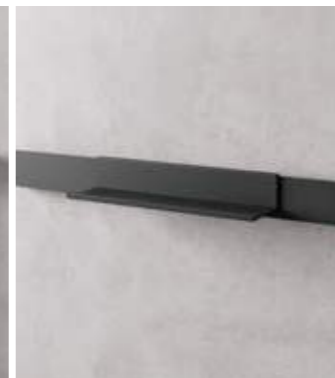

MENSOLA

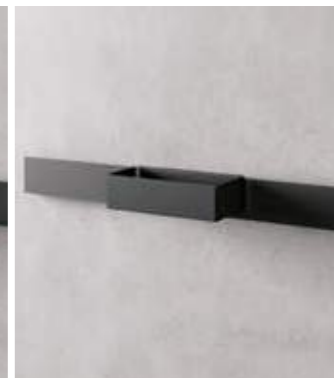

VASCHETTA

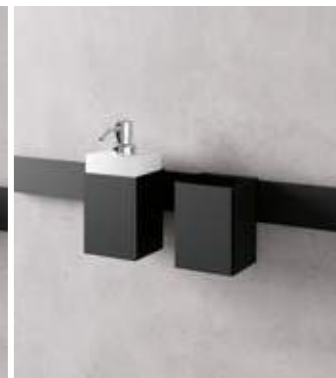

BICCHIERE - PORTASAPONE



PORTAPHON



PORTASMARTPHONE

ACCESSORI TRATTO



PORTASALVIETTE



APPENDINO



APPENDIABITO



PORTAROTOLO

**Finiture**

Finishes  
Finitions  
Ausführungen  
Acabados

**Laccato opaco/lucido**

Matt/gloss lacquered / Lacquée mat et brillant  
Matt oder glänzend lackiert / Lacado mate y brillo

						
BIANCO 01	NUVOLA 58	CENERE 06	KAKI 07	GRAFITE 02	FERRO 03	NERO 04
						
VANIGLIA 59	JUTA 60	CANAPA 61	LIQUIRIZIA 62	FANGO 63	TERRA 14	CACAO 64
						
PAPIRO 57	AVENA 56	FIENO 55	GIADA 38	BOSCO 37	PETROLIO 72	NAFTA 75
						
TURCHESE 74	MENTA 73	PAVONE 71	VERDE VERONESE 76	FORESTA 77	NEBBIA 39	POLVERE 46
						
ANICE 49	AVIO 44	BLU MOBY 47	OLTREMARE 48	LINO 19	FINESTRA 08	FARD 54
						
CIPRIA 53	CARMINIO 29	MATTONE 65	BORDEAUX 24	ROSSO INDIA 26	AMBRA 16	ZAFFERANO 15
			*Solo opaco Matt only / Seulement mat Nur matt / Solo mate			
MET. ALLUMINIO 05	MET. ORO 17	MET. TITANIO 09				RAL + NCS

**Finiture**

Finishes  
Finitions  
Ausführungen  
Acabados

**Laccato metal**

Metal lacquered / Lacqué Metal  
Metal lackiert / Lacado Metal

		
OTTONE ANTICO	CORTEN	ACCIAIO









**Bimelaminico skin**

Bimelaminated Skin / Bi-mé laminé Skin  
Bimelamin Skin / Bi-melamina Skin

		
SKIN BIANCO	SKIN GRIGIO	SKIN JEREZ

**Bimelaminico syncro**

Bimelaminated Syncro / Bi-mé laminé Syncro  
Bimelamin Syncro / Bi-melamina Syncro

					
ARES BETON	ARES CALCE	ROVERE SPACCATO	MINATO	SHIBUYA	NODATO CANYON
					
OLMO COCCO	NODATO LONDRA	NODATO SAVANA			

### Finiture

Finishes  
Finitions  
Ausführungen  
Acabados

### Legni



ROVERE NORDICO NATURALE ROVERE NORDICO CIOCCOLATO ROVERE NORDICO CAFFÈ NOCE CANALETTO OLMO EUCALIPTO AFFUMICATO

### Rovere fiammato decapé

Decapé Fiammato Oak / Chêne Fiammato Decapé  
Decapé Fiammato Eiche / Roble Fiammato Decapé

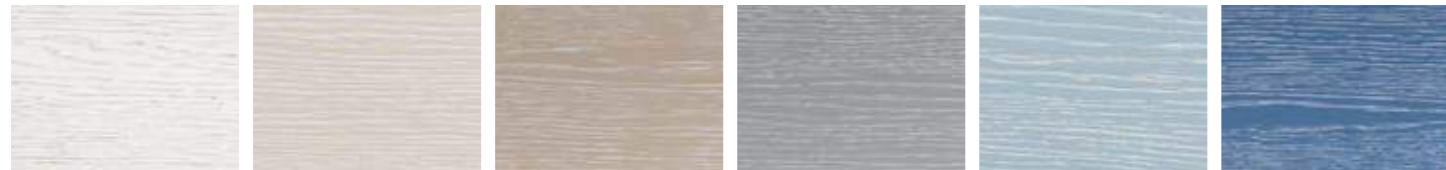

BIANCO PORO SCURO JUTA PORO BIANCO CANAPA PORO BIANCO FINESTRA PORO BIANCO POLVERE PORO BIANCO AVIO PORO BIANCO

### Rovere fiammato tinto

Fiammato Oak / Chêne Fiammato Teinté  
Fiammato Eiche / Roble Fiammato



AGATA CASTAGNA CORDA GRANO QUARZO TARTUFO

### Terre

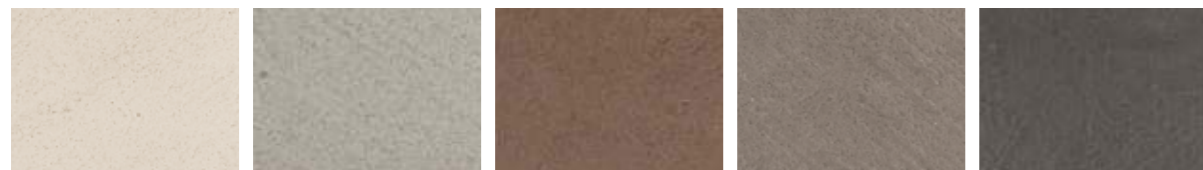

PERLESCENTE MASTICE OMBRA ROMA VITE

### Finiture

Finishes  
Finitions  
Ausführungen  
Acabados

### Hpl unicolor



STATUARIO S. T. 439 CEMENTO 143 OLMO SCURO 303 OLMO BIONDO 134 ROVERE MONET 423 ROVERE TEXAS 306 ROVERE VERSAILLES 418



ROVERE CASTORO 301 SASSO 139 BASALTO 403 PORFIDO 119 OSSIDO 146 ARDESIA 145 MALTA BIANCA 430



MALTA GRIGIA 431 MALTA CANAPA 432 ANTIQUE BOTTICINO 410 CUMA DARK 428 CALYPSO 435 TOBACCO 440



IMPERO 438

### Fenix



GRIGIO EFESO 725 VERDE COMODORO 750 BLU FES 754



BIANCO 32 NERO 720 BIBER 717 BROMO 724 GRIGIO 718

CATALOGUE PLANNIG  
**Maurizio Poletto**

R. & S.  
**Archeda Srl**

DESIGN E A.D.  
**Dario Poles**

GRAPHIC DESIGN CATALOGO  
**Graphosds**

FOTOGRAFIA  
**Gabriotti Fotografi**

FOTOLITO E STAMPA  
**graficheitalprint.it**

**OTTOBRE 2022**

**Archeda, al fine di migliorare le caratteristiche tecniche e qualitative della sua produzione, si riserva di apportare, anche senza preavviso, tutte le modifiche che si rendessero necessarie.**

To improve the technical and the qualitative characteristics of the production, Archeda reserves the right to make all the suitable modifications without previous notice.

A fin daméliorer les caractéristiques techniques et qualitatives de sa production, la société Archeda se réserve le droit d'apporter, même sans preavis, toutes les modifications qui seront jugées nécessaires.

Um technische und qualitative Merkmale der Produktion zu verbessern, behält sich Archeda vor, alle nötige Abänderungen, ohne Avisierungen, vorzunehmen.

Archeda, a fin de mejorar las características técnicas y cualitativas de su producción, se reserva el derecho de aportar, incluso sin previo aviso, todas las modificaciones necesarias.

